



North/Latin America
Europe/Africa
Asia/Oceania

Internal Use Only

<http://aic.lgservice.com>
<http://eic.lgservice.com>
<http://biz.lgservice.com>

LCD TV

SERVICE MANUAL

CHASSIS : LA01U

MODEL : 26LK330 26LK330-UB

CAUTION

BEFORE SERVICING THE CHASSIS,
READ THE SAFETY PRECAUTIONS IN THIS MANUAL.



CONTENTS

CONTENTS	2
SAFETY PRECAUTIONS	3
SPECIFICATION	6
ADJUSTMENT INSTRUCTION	10
EXPLODED VIEW	16
SVC. SHEET	

SAFETY PRECAUTIONS

IMPORTANT SAFETY NOTICE

Many electrical and mechanical parts in this chassis have special safety-related characteristics. These parts are identified by ⚠ in the Schematic Diagram and Exploded View.

It is essential that these special safety parts should be replaced with the same components as recommended in this manual to prevent Shock, Fire, or other Hazards.

Do not modify the original design without permission of manufacturer.

General Guidance

An **isolation Transformer should always be used** during the servicing of a receiver whose chassis is not isolated from the AC power line. Use a transformer of adequate power rating as this protects the technician from accidents resulting in personal injury from electrical shocks.

It will also protect the receiver and its components from being damaged by accidental shorts of the circuitry that may be inadvertently introduced during the service operation.

If any fuse (or Fusible Resistor) in this TV receiver is blown, replace it with the specified.

When replacing a high wattage resistor (Oxide Metal Film Resistor, over 1W), keep the resistor 10mm away from PCB.

Keep wires away from high voltage or high temperature parts.

Before returning the receiver to the customer,

always perform an **AC leakage current check** on the exposed metallic parts of the cabinet, such as antennas, terminals, etc., to be sure the set is safe to operate without damage of electrical shock.

Leakage Current Cold Check(Antenna Cold Check)

With the instrument AC plug removed from AC source, connect an electrical jumper across the two AC plug prongs. Place the AC switch in the on position, connect one lead of ohm-meter to the AC plug prongs tied together and touch other ohm-meter lead in turn to each exposed metallic parts such as antenna terminals, phone jacks, etc.

If the exposed metallic part has a return path to the chassis, the measured resistance should be between $1M\Omega$ and $5.2M\Omega$.

When the exposed metal has no return path to the chassis the reading must be infinite.

An other abnormality exists that must be corrected before the receiver is returned to the customer.

Leakage Current Hot Check (See below Figure)

Plug the AC cord directly into the AC outlet.

Do not use a line Isolation Transformer during this check.

Connect 1.5K/10watt resistor in parallel with a 0.15uF capacitor between a known good earth ground (Water Pipe, Conduit, etc.) and the exposed metallic parts.

Measure the AC voltage across the resistor using AC voltmeter with 1000 ohms/volt or more sensitivity.

Reverse plug the AC cord into the AC outlet and repeat AC voltage measurements for each exposed metallic part. Any voltage measured must not exceed 0.75 volt RMS which corresponds to 0.5mA.

In case any measurement is out of the limits specified, there is possibility of shock hazard and the set must be checked and repaired before it is returned to the customer.

Leakage Current Hot Check circuit

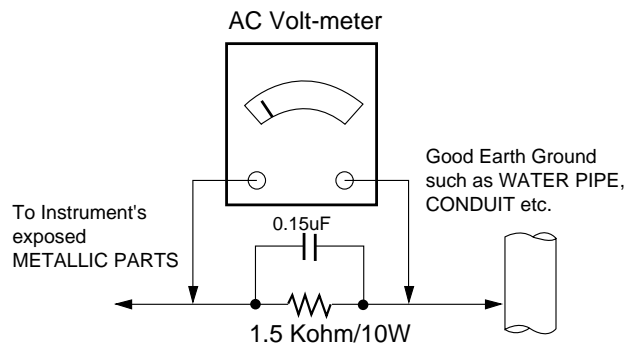

SERVICING PRECAUTIONS

CAUTION: Before servicing receivers covered by this service manual and its supplements and addenda, read and follow the *SAFETY PRECAUTIONS* on page 3 of this publication.

NOTE: If unforeseen circumstances create conflict between the following servicing precautions and any of the safety precautions on page 3 of this publication, always follow the safety precautions. Remember: Safety First.

General Servicing Precautions

1. Always unplug the receiver AC power cord from the AC power source before;
 - a. Removing or reinstalling any component, circuit board module or any other receiver assembly.
 - b. Disconnecting or reconnecting any receiver electrical plug or other electrical connection.
 - c. Connecting a test substitute in parallel with an electrolytic capacitor in the receiver.

CAUTION: A wrong part substitution or incorrect polarity installation of electrolytic capacitors may result in an explosion hazard.

2. Test high voltage only by measuring it with an appropriate high voltage meter or other voltage measuring device (DVM, FETVOM, etc) equipped with a suitable high voltage probe. Do not test high voltage by "drawing an arc".

3. Do not spray chemicals on or near this receiver or any of its assemblies.

4. Unless specified otherwise in this service manual, clean electrical contacts only by applying the following mixture to the contacts with a pipe cleaner, cotton-tipped stick or comparable non-abrasive applicator; 10% (by volume) Acetone and 90% (by volume) isopropyl alcohol (90%-99% strength)

CAUTION: This is a flammable mixture.

Unless specified otherwise in this service manual, lubrication of contacts is not required.

5. Do not defeat any plug/socket B+ voltage interlocks with which receivers covered by this service manual might be equipped.
6. Do not apply AC power to this instrument and/or any of its electrical assemblies unless all solid-state device heat sinks are correctly installed.

7. Always connect the test receiver ground lead to the receiver chassis ground before connecting the test receiver positive lead.

Always remove the test receiver ground lead last.

8. *Use with this receiver only the test fixtures specified in this service manual.*

CAUTION: Do not connect the test fixture ground strap to any heat sink in this receiver.

Electrostatically Sensitive (ES) Devices

Some semiconductor (solid-state) devices can be damaged easily by static electricity. Such components commonly are called *Electrostatically Sensitive (ES) Devices*. Examples of typical ES devices are integrated circuits and some field-effect transistors and semiconductor "chip" components. The following techniques should be used to help reduce the incidence of component damage caused by static by static electricity.

1. Immediately before handling any semiconductor component or semiconductor-equipped assembly, drain off any electrostatic charge on your body by touching a known earth ground. Alternatively, obtain and wear a commercially available discharging wrist strap device, which should be removed to prevent potential shock reasons prior to applying power to the

unit under test.

2. After removing an electrical assembly equipped with ES devices, place the assembly on a conductive surface such as aluminum foil, to prevent electrostatic charge buildup or exposure of the assembly.

3. Use only a grounded-tip soldering iron to solder or unsolder ES devices.

4. Use only an anti-static type solder removal device. Some solder removal devices not classified as "anti-static" can generate electrical charges sufficient to damage ES devices.

5. Do not use freon-propelled chemicals. These can generate electrical charges sufficient to damage ES devices.

6. Do not remove a replacement ES device from its protective package until immediately before you are ready to install it. (Most replacement ES devices are packaged with leads electrically shorted together by conductive foam, aluminum foil or comparable conductive material).

7. Immediately before removing the protective material from the leads of a replacement ES device, touch the protective material to the chassis or circuit assembly into which the device will be installed.

CAUTION: Be sure no power is applied to the chassis or circuit, and observe all other safety precautions.

8. Minimize bodily motions when handling unpackaged replacement ES devices. (Otherwise harmless motion such as the brushing together of your clothes fabric or the lifting of your foot from a carpeted floor can generate static electricity sufficient to damage an ES device.)

General Soldering Guidelines

1. Use a grounded-tip, low-wattage soldering iron and appropriate tip size and shape that will maintain tip temperature within the range or 500°F to 600°F.

2. Use an appropriate gauge of RMA resin-core solder composed of 60 parts tin/40 parts lead.

3. Keep the soldering iron tip clean and well tinned.

4. Thoroughly clean the surfaces to be soldered. Use a mall wire-bristle (0.5 inch, or 1.25cm) brush with a metal handle.

Do not use freon-propelled spray-on cleaners.

5. Use the following unsoldering technique

- a. Allow the soldering iron tip to reach normal temperature. (500°F to 600°F)

- b. Heat the component lead until the solder melts.

- c. Quickly draw the melted solder with an anti-static, suction-type solder removal device or with solder braid.

CAUTION: Work quickly to avoid overheating the circuit board printed foil.

6. Use the following soldering technique.

- a. Allow the soldering iron tip to reach a normal temperature (500°F to 600°F)

- b. First, hold the soldering iron tip and solder the strand against the component lead until the solder melts.

- c. Quickly move the soldering iron tip to the junction of the component lead and the printed circuit foil, and hold it there only until the solder flows onto and around both the component lead and the foil.

CAUTION: Work quickly to avoid overheating the circuit board printed foil.

- d. Closely inspect the solder area and remove any excess or splashed solder with a small wire-bristle brush.

IC Remove/Replacement

Some chassis circuit boards have slotted holes (oblong) through which the IC leads are inserted and then bent flat against the circuit foil. When holes are the slotted type, the following technique should be used to remove and replace the IC. When working with boards using the familiar round hole, use the standard technique as outlined in paragraphs 5 and 6 above.

Removal

1. Desolder and straighten each IC lead in one operation by gently prying up on the lead with the soldering iron tip as the solder melts.
2. Draw away the melted solder with an anti-static suction-type solder removal device (or with solder braid) before removing the IC.

Replacement

1. Carefully insert the replacement IC in the circuit board.
2. Carefully bend each IC lead against the circuit foil pad and solder it.
3. Clean the soldered areas with a small wire-bristle brush. (It is not necessary to reapply acrylic coating to the areas).

"Small-Signal" Discrete Transistor

Removal/Replacement

1. Remove the defective transistor by clipping its leads as close as possible to the component body.
2. Bend into a "U" shape the end of each of three leads remaining on the circuit board.
3. Bend into a "U" shape the replacement transistor leads.
4. Connect the replacement transistor leads to the corresponding leads extending from the circuit board and crimp the "U" with long nose pliers to insure metal to metal contact then solder each connection.

Power Output, Transistor Device

Removal/Replacement

1. Heat and remove all solder from around the transistor leads.
2. Remove the heat sink mounting screw (if so equipped).
3. Carefully remove the transistor from the heat sink of the circuit board.
4. Insert new transistor in the circuit board.
5. Solder each transistor lead, and clip off excess lead.
6. Replace heat sink.

Diode Removal/Replacement

1. Remove defective diode by clipping its leads as close as possible to diode body.
2. Bend the two remaining leads perpendicular y to the circuit board.
3. Observing diode polarity, wrap each lead of the new diode around the corresponding lead on the circuit board.
4. Securely crimp each connection and solder it.
5. Inspect (on the circuit board copper side) the solder joints of the two "original" leads. If they are not shiny, reheat them and if necessary, apply additional solder.

Fuse and Conventional Resistor

Removal/Replacement

1. Clip each fuse or resistor lead at top of the circuit board hollow stake.
2. Securely crimp the leads of replacement component around notch at stake top.
3. Solder the connections.

CAUTION: Maintain original spacing between the replaced component and adjacent components and the circuit board to prevent excessive component temperatures.

Circuit Board Foil Repair

Excessive heat applied to the copper foil of any printed circuit board will weaken the adhesive that bonds the foil to the circuit board causing the foil to separate from or "lift-off" the board. The following guidelines and procedures should be followed whenever this condition is encountered.

At IC Connections

To repair a defective copper pattern at IC connections use the following procedure to install a jumper wire on the copper pattern side of the circuit board. (Use this technique only on IC connections).

1. Carefully remove the damaged copper pattern with a sharp knife. (Remove only as much copper as absolutely necessary).
2. Carefully scratch away the solder resist and acrylic coating (if used) from the end of the remaining copper pattern.
3. Bend a small "U" in one end of a small gauge jumper wire and carefully crimp it around the IC pin. Solder the IC connection.
4. Route the jumper wire along the path of the out-away copper pattern and let it overlap the previously scraped end of the good copper pattern. Solder the overlapped area and clip off any excess jumper wire.

At Other Connections

Use the following technique to repair the defective copper pattern at connections other than IC Pins. This technique involves the installation of a jumper wire on the component side of the circuit board.

1. Remove the defective copper pattern with a sharp knife. Remove at least 1/4 inch of copper, to ensure that a hazardous condition will not exist if the jumper wire opens.
2. Trace along the copper pattern from both sides of the pattern break and locate the nearest component that is directly connected to the affected copper pattern.
3. Connect insulated 20-gauge jumper wire from the lead of the nearest component on one side of the pattern break to the lead of the nearest component on the other side. Carefully crimp and solder the connections.
CAUTION: Be sure the insulated jumper wire is dressed so the it does not touch components or sharp edges.

SPECIFICATION

NOTE : Specifications and others are subject to change without notice for improvement.

1. Application range

This spec sheet is applied LCD TV with 26" LA01T chassis.

- 1) Performance: LGE TV test method followed
- 2) Demanded other specification
 - Safety : UL, CSA, IEC specification
 - EMC: FCC, ICES, IEC specification

2. Requirement for Test

Each part is tested as below without special appointment.

- 1) Temperature: 25 °C ± 5 °C
- 2) Relative Humidity: 65 ± 10 %
- 3) Power Voltage : Standard input voltage(100-240V~, 50/60Hz)
 - * Standard Voltage of each product is marked by models
- 4) Specification and performance of each parts are followed each drawing and specification by part number in accordance with BOM.
- 5) The receiver must be operated for about 5 minutes prior to the adjustment.

3. Test method

4. General Specification(TV)

No	Item	Specification		Remark
1	Receivable System	1) ATSC / NTSC-M		
2	Available Channel	1) VHF : 02 ~ 13 2) UHF : 14 ~ 69 3) DTV : 02 ~ 69 4) CATV : 01 ~ 135 5) CADTV : 01 ~ 135		
3	Input Voltage	1) AC 100 - 240V~ 50/60Hz		Mark : 110V, 60Hz (N.Ame)
4	Market	North America		
5	Screen Size	26 inch Wide (1366x768)	HD + 60Hz	26LK330-UB
6	Aspect Ratio	16:9		
7	Tuning System	FS		
8	LCD Module	T260XW04-V9	AUO	26LK330-UB
9	Operating Environment	Temp : 0 ~ 40 deg Humidity : ~ 80 %		
10	Storage Environment	Temp : -20 ~ 60 deg Humidity : -85 %		

5. Chrominance & Luminance

No.	Item			Min	Typ	Max	Unit	Remarks
1	Max Luminance (Center 1-point / Full White Pattern)			360	400		cd/m ²	26LK330-UB
2	Luminance uniformity							
3	Color coordinate (Default)	RED	X	Typ. -0.03	0.64	Typ. +0.03		26LK330-UB
			Y		0.33			
		GREEN	X		0.28			
			Y		0.59			
		BLUE	X		0.15			
			Y		0.05			
		WHITE	X		0.28			
			Y		0.29			
4	Contrast ratio	Module		2400	3000			26LK330-UB
		DCR		90,000:1	100,000:1			AUO
5	Color Temperature	Cool		0.254	0.269	0.284	13000K	The W/B Tolerance is ±0.015 for picture quality by DQA
				0.258	0.273	0.288		
		Medium		0.270	0.285	0.300	9300K	
				0.278	0.293	0.308		
		Warm		0.298	0.313	0.324	6500K	
				0.314	0.329	0.344		

6. Component Video Input (Y, CB/PB, CR/PR)

No	Resolution	H-freq(kHz)	V-freq.(kHz)	Pixel clock	Proposed
1.	720*480	15.73	60	13.5135	SDTV ,DVD 480I
2.	720*480	15.73	59.94	13.5	SDTV ,DVD 480I
3.	720*480	31.50	60	27.027	SDTV 480P
4.	720*480	31.47	59.94	27.0	SDTV 480P
5.	1280*720	45.00	60.00	74.25	HDTV 720P
6.	1280*720	44.96	59.94	74.176	HDTV 720P
7.	1920*1080	33.75	60.00	74.25	HDTV 1080I
8.	1920*1080	33.72	59.94	74.176	HDTV 1080I
9.	1920*1080	67.500	60	148.50	HDTV 1080P
10.	1920*1080	67.432	59.94	148.352	HDTV 1080P
11.	1920*1080	27.000	24.000	74.25	HDTV 1080P
12.	1920*1080	26.97	23.976	74.176	HDTV 1080P
13.	1920*1080	33.75	30.000	74.25	HDTV 1080P
14.	1920*1080	33.71	29.97	740176	HDTV 1080P

7. RGB Input (PC)

No	Resolution	H-freq(kHz)	V-freq.(kHz)	Pixel clock	Proposed	
	PC					DDC
1.	640*350	31.468	70.09	25.17	EGA	X
2.	720*400	31.469	70.08	28.32	DOS	O
3.	640*480	31.469	59.94	25.17	VESA(VGA)	O
4.	800*600	37.879	60.31	40.00	VESA(SVGA)	O
5.	1024*768	48.363	60.00	65.00	VESA(XGA)	O
6.	1280*768	47.776	59.870	79.5	CVT(WXGA)	X
7.	1360*768	47.712	60.015	85.50	VESA(WXGA)	X
8.	1280*1024	63.981	60.020	108.00	VESA(SXGA)	O
9.	1920*1080	66.587	59.934	138.50	WUXGA	O

8. HDMI input (PC/DTV)

No	Resolution	H-freq(kHz)	V-freq.(kHz)	Pixel clock	Proposed	
	PC					DDC
1.	640*350	31.468	70.09	25.17	EGA	X
2.	720*400	31.469	70.08	28.32	DOS	O
3.	640*480	31.469	59.94	25.17	VESA(VGA)	X
4.	800*600	37.879	60.31	40.00	VESA(SVGA)	O
5.	1024*768	48.363	60.00	65.00	VESA(XGA)	O
6.	1280*768	47.776	59.870	79.5	CVT(WXGA)	X
7.	1360*768	47.712	60.015	85.50	VESA (WXGA)	O
8.	1280*1024	63.981	60.020	108.00	VESA (SXGA)	O
9.	1920*1080	67.500	60.000	148.50	HDTV 1080P	O
	DTV					
1	720*480	31.47	60	27.027	SDTV 480P	O
2	720*480	31.47	59.94	27.00	SDTV 480P	O
3	1280*720	45.00	60.00	74.25	HDTV 720P	O
4	1280*720	44.96	59.94	74.176	HDTV 720P	O
5	1920*1080	33.75	60.00	74.25	HDTV 1080I	O
6	1920*1080	33.72	59.94	74.176	HDTV 1080I	O
7	1920*1080	67.500	60	148.50	HDTV 1080P	O
8	1920*1080	67.432	59.939	148.352	HDTV 1080P	O
9	1920*1080	27.000	24.000	74.25	HDTV 1080P	O
10	1920*1080	26.97	23.976	74.176	HDTV 1080P	O
11	1920*1080	33.75	30.000	74.25	HDTV 1080P	O
12	1920*1080	33.71	29.97	74.176	HDTV 1080P	O

4.2. EDID/DDC Download

4.2.1 Overview

- It is a VESA regulation. A PC or a MNT will display an optimal resolution through information sharing without any necessity of user input. It is a realization of "Plug and Play".

4.2.2 Equipment

- Since embedded EDID data is used, EDID download JIG, HDMI cable and D-sub cable are not need.
- Adjust remocon.

4.2.3 Download method

- Press Adj. key on the Adj. R/C,
- Select EDID D/L menu.
- By pressing Enter key, EDID download will begin
- If Download is successful, OK is display, but If Download is failure, NG is displayed.
- If Download is failure, Re-try downloads.

* Caution) When EDID Download, must remove RGB/HDMI Cable.

4.2.4 EDID DATA

1) North America

HDMI1-EDID (C/S : 03CC)

EDID Block 0

0 1 2 3 4 5 6 7 8 9 A B C D E F

```

0 | 00 FF FF FF FF FF FF 00 1E 6D 01 00 01 01 01 01
10 | 01 15 01 03 80 10 09 78 0A EE 91 A3 54 4C 99 26
20 | 0F 50 54 A1 08 00 81 80 61 40 45 40 31 40 01 01
30 | 01 01 01 01 01 01 02 3A 80 18 71 38 2D 40 58 2C
40 | 45 00 A0 5A 00 00 00 1E 01 1D 00 72 51 D0 1E 20
50 | 6E 28 55 00 A0 5A 00 00 00 1E 00 00 00 FD 00 39
60 | 3F 1F 52 10 00 0A 20 20 20 20 20 20 00 00 00 FC
70 | 00 4C 47 20 54 56 0A 20 20 20 20 20 20 01 03

```

Block1

0 1 2 3 4 5 6 7 8 9 A B C D E F

```

0 | 02 03 1C F1 47 10 22 20 05 84 03 02 23 09 07 07
10 | 67 03 0C 00 10 00 B8 2D E3 05 03 01 02 3A 80 18
20 | 71 38 2D 40 58 2C 04 05 A0 5A 00 00 00 1E 01 1D
30 | 80 18 71 1C 16 20 58 2C 25 00 A0 5A 00 00 00 9E
40 | 01 1D 00 72 51 D0 1E 20 6E 28 55 00 A0 5A 00 00
50 | 00 1E 8C 0A D0 8A 20 E0 2D 10 10 3E 96 00 A0 5A
60 | 00 00 00 18 26 36 80 A0 70 38 1F 40 30 20 25 00
70 | A0 5A 00 00 00 1A 00 00 00 00 00 00 00 00 00 CC

```

HDMI2-EDID (C/S : 03BC)

Block0

0 1 2 3 4 5 6 7 8 9 A B C D E F

```

0 | 00 FF FF FF FF FF FF 00 1E 6D 01 00 01 01 01 01
10 | 01 15 01 03 80 10 09 78 0A EE 91 A3 54 4C 99 26
20 | 0F 50 54 A1 08 00 81 80 61 40 45 40 31 40 01 01
30 | 01 01 01 01 01 01 02 3A 80 18 71 38 2D 40 58 2C
40 | 45 00 A0 5A 00 00 00 1E 01 1D 00 72 51 D0 1E 20
50 | 6E 28 55 00 A0 5A 00 00 00 1E 00 00 00 FD 00 39
60 | 3F 1F 52 10 00 0A 20 20 20 20 20 20 00 00 00 FC
70 | 00 4C 47 20 54 56 0A 20 20 20 20 20 20 01 03

```

Block1

0 1 2 3 4 5 6 7 8 9 A B C D E F

```

0 | 02 03 1C F1 47 10 22 20 05 84 03 02 23 09 07 07
10 | 67 03 0C 00 20 00 B8 2D E3 05 03 01 02 3A 80 18
20 | 71 38 2D 40 58 2C 04 05 A0 5A 00 00 00 1E 01 1D
30 | 80 18 71 1C 16 20 58 2C 25 00 A0 5A 00 00 00 9E
40 | 01 1D 00 72 51 D0 1E 20 6E 28 55 00 A0 5A 00 00
50 | 00 1E 8C 0A D0 8A 20 E0 2D 10 10 3E 96 00 A0 5A
60 | 00 00 00 18 26 36 80 A0 70 38 1F 40 30 20 25 00
70 | A0 5A 00 00 00 1A 00 00 00 00 00 00 00 00 00 BC

```

HDMI3-EDID (C/S : 03AC)

Block0

0 1 2 3 4 5 6 7 8 9 A B C D E F

```

0 | 00 FF FF FF FF FF FF 00 1E 6D 01 00 01 01 01 01
10 | 01 15 01 03 80 10 09 78 0A EE 91 A3 54 4C 99 26
20 | 0F 50 54 A1 08 00 81 80 61 40 45 40 31 40 01 01
30 | 01 01 01 01 01 01 02 3A 80 18 71 38 2D 40 58 2C
40 | 45 00 A0 5A 00 00 00 1E 01 1D 00 72 51 D0 1E 20
50 | 6E 28 55 00 A0 5A 00 00 00 1E 00 00 00 FD 00 39
60 | 3F 1F 52 10 00 0A 20 20 20 20 20 20 00 00 00 FC
70 | 00 4C 47 20 54 56 0A 20 20 20 20 20 20 01 03

```

Block1

0 1 2 3 4 5 6 7 8 9 A B C D E F

```

0 | 02 03 1C F1 47 10 22 20 05 84 03 02 23 09 07 07
10 | 67 03 0C 00 30 00 B8 2D E3 05 03 01 02 3A 80 18
20 | 71 38 2D 40 58 2C 04 05 A0 5A 00 00 00 1E 01 1D
30 | 80 18 71 1C 16 20 58 2C 25 00 A0 5A 00 00 00 9E
40 | 01 1D 00 72 51 D0 1E 20 6E 28 55 00 A0 5A 00 00
50 | 00 1E 8C 0A D0 8A 20 E0 2D 10 10 3E 96 00 A0 5A
60 | 00 00 00 18 26 36 80 A0 70 38 1F 40 30 20 25 00
70 | A0 5A 00 00 00 1A 00 00 00 00 00 00 00 00 00 AC

```

RGB-EDID (C/S : 1C)

Block0

0 1 2 3 4 5 6 7 8 9 A B C D E F

```

0 | 00 FF FF FF FF FF FF 00 1E 6D 01 00 01 01 01 01
10 | 01 15 01 03 68 10 09 78 0A EE 91 A3 54 4C 99 26
20 | 0F 50 54 A1 08 00 81 80 61 40 45 40 31 40 01 01
30 | 01 01 01 01 01 01 02 3A 80 18 71 38 2D 40 58 2C
40 | 45 00 A0 5A 00 00 00 1E 01 1D 00 72 51 D0 1E 20
50 | 6E 28 55 00 A0 5A 00 00 00 1E 00 00 00 FD 00 3A
60 | 3E 1E 53 10 00 0A 20 20 20 20 20 20 00 00 00 FC
70 | 00 4C 47 20 54 56 0A 20 20 20 20 20 20 00 00 1C

```

5. Final Assembly Adjustment

5.1. White Balance Adjustment

5.1.1. Overview

5.1.1.1. W/B adj. Objective & How-it-works

- (1) Objective: To reduce each Panel's W/B deviation
- (2) How-it-works: When R/G/B gain in the OSD is at 192, it means the panel is at its Full Dynamic Range. In order to prevent saturation of Full Dynamic range and data, one of R/G/B is fixed at 192, and the other two is lowered to find the desired value.
- (3) Adj. condition: normal temperature
 - 1) Surrounding Temperature: 25±5°C
 - 2) Warm-up time: About 5 Min
 - 3) Surrounding Humidity: 20% ~ 80%

5.1.2. Equipment

- (1) Color Analyzer: CA-210 (NCG: CH 9 / WCG: CH12 / LED: CH14)
 - (2) Adj. Computer (During auto adj., RS-232C protocol is needed)
 - (3) Adjust Remocon
 - (4) Video Signal Generator MSPG-925F 720p/204-Gray (Model: 217, Pattern: 49)
- Color Analyzer Matrix should be calibrated using CS-1000

5.1.3. Equipment connection

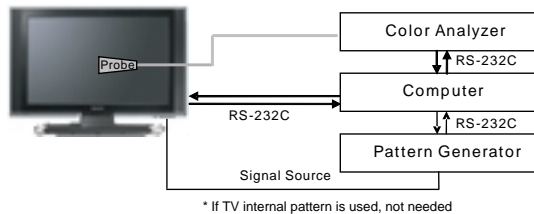

Connection Diagram of Automatic Adjustment

5.1.4. Adjustment Command (Protocol)

- (1) RS-232C Command used during auto-adj.

RS-232C COMMAND			Explanation
[CMD]	ID	DATA]	
Wb	00	00	Begin White Balance adj.
Wb	00	ff	End White Balance adj. (internal pattern disappears)

- Ex) wb 00 00 -> Begin white balance auto-adj.
 wb 00 10 -> Gain adj.
 ja 00 ff -> Adj. data
 jb 00 c0
 ...
 ...
 wb 00 1f -> Gain adj. complete

- *(wb 00 20(start), wb 00 2f(end)) -> Off-set adj.
 wb 00 ff ->End white balance auto adj.

(2) Adj. Map

Applied Model :

32/37/42/47LK450-UB, 32/42/47LK450-NA, 32/42/47LK451-NB, 32/42/47LK452-NC, 32LK330-UB, 32/42LK430-UA, 42/47/55LK520-UA, 32LK330-NB, 42LK430-NA, 42/47/55LK530-NA

Adj.	item	Command (lower case ASCII)		Data Range (Hex.)		Default (Decimal)
		CMD1	CMD2	MIN	MAX	
Cool	R Gain	j	g	00	C0	172
	G Gain	j	h	00	C0	172
	B Gain	j	i	00	C0	192
	R Cut					64
	G Cut					64
	B Cut					64
Medium	R Gain	j	a	00	C0	192
	G Gain	j	b	00	C0	192
	B Gain	j	c	00	C0	192
	R Cut					64
	G Cut					64
	B Cut					64
Warm	R Gain	j	d	00	C0	192
	G Gain	j	e	00	C0	192
	B Gain	j	f	00	C0	172
	R Cut					64
	G Cut					64
	B Cut					64

5.1.5. Adjustment method

5.1.5.1 Auto WB calibration

- 1) Set TV in adj. mode using POWER ONLY (P-ONLY) key
- 2) Zero calibrate probe then place it on the center of the Display
- 3) Connect Cable(RS-232C)
- 4) Select mode in adj. Program and begin adj.
- 5) When adj. is complete (OK Sing), check adj. status pre mode (Cool, Medium, Warm)
- 6) Remove probe and RS-232C cable to complete adj.

- W/B Adj. must begin as start command "wb 00 00" , and finish as end command "wb 00 ff", and Adj. offset if need

5.1.5.2 Manual adj. method

- 1) Set TV in Adj. mode using POWER ON
- 2) Zero Calibrate the probe of Color Analyzer, then place it on the center of LCD module within 10cm of the surface..
- 3) Press ADJ key -> EZ adjust using adj. R/C 6. White-Balance then press the cursor to the right (KEYG). (When KEY(G) is pressed 204 Gray(80IRE) internal pattern will be displayed)
- 4) One of R Gain / G Gain / B Gain should be fixed at 192, and the rest will be lowered to meet the desired value.
- 5) Adj. is performed in COOL, MEDIUM, WARM 3 modes of color temperature.

- If internal pattern is not available, use RF input. In EZ Adj. menu 6.White Balance, you can select one of 2 Test-pattern: ON, OFF. Default is inner(ON). By selecting OFF, you can adjust using RF signal in 204 Gray pattern.

- Adj. condition and cautionary items
 - 1) Lighting condition in surrounding area
Surrounding lighting should be lower 10 lux. Try to isolate adj. area into dark surrounding.
 - 2) Probe location : Color Analyzer (CA-210) probe should be within 10cm and perpendicular of the module surface (80°~100°)
 - 3) Aging time
 - After Aging Start, Keep the Power ON status during 5 Minutes.
 - In case of LCD, Back-light on should be checked using no signal or Full-white pattern.

5.1.6 Reference (White Balance Adj. coordinate and color temperature)

- (1) Luminance: 204 Gray, 80IRE
- (2) Standard color coordinate and temperature using CS-1000 (over 26 inch)

Mode	Color Coordination		Temp	ΔUV
	x	y		
COOL	0.269	0.273	13000K	0.0000
MEDIUM	0.285	0.293	9300K	0.0000
WARM	0.313	0.329	6500K	0.0000

- Standard color coordinate and temperature using CA-210(CH 9)

Mode	Color Coordination		Temp	ΔUV
	x	y		
COOL	0.269±0.002	0.273±0.002	13000K	0.0000
MEDIUM	0.285±0.002	0.293±0.002	9300K	0.0000
WARM	0.313±0.002	0.329±0.002	6500K	0.0000

5.2 HDCP (High-Bandwidth Digital Contents Protection) SETTING

5.3 Option selection per country

5.3.1 Overview

- Option selection is only done for models in Non-USA North America due to rating
- Applied model: LA01U Chassis applied None USA model(CANADA, MEXICO)

5.3.2 Method

- (1) Press ADJ key on the Adj. R/C, and then select Country Group Menu
- (2) Depending on destination, select KR or US, then on the lower Country option, select US, CA, MX. Selection is done using +, - KEY

5.4 Tool Option selection

- Method: Press Adj. key on the Adj. R/C, then select Tool option.

Model	Tool1	Tool2	Tool3	Tool4	Tool5	Menu
26LK330-UB	13896	18966	51209	2328	290	AUO

5.5 Ship-out mode check (In-stop)

- After final inspection, press In-Stop key of the Adj. R/C and check that the unit goes to Stand-by mode.

6. GND and Hi-pot Test

6.1. Method

6.1.1. GND & HI-POT auto-check preparation

- (1) Check the POWER CABLE and SIGNAL CABLE insertion condition

6.1.2. GND & HI-POT auto-check

- (1) Pallet moves in the station. (POWER CORD / AV CORD is tightly inserted)
- (2) Connect the AV JACK Tester.
- (3) Controller (GWS103-4) on.
- (4) GND Test (Auto)
 - If Test is failed, Buzzer operates.
 - If Test is passed, execute next process (Hi-pot test). (Remove A/V CORD from A/V JACK BOX)
- (5) HI-POT test (Auto)
 - If Test is failed, Buzzer operates.
 - If Test is passed, GOOD Lamp on and move to next process automatically.

6.2. Checkpoint

- TEST voltage
 - GND: 1.5KV/min at 100mA
 - SIGNAL: 3KV/min at 100mA
- TEST time: 1 second
- TEST POINT
 - GND TEST = POWER CORD GND & SIGNAL CABLE METAL GND
 - Internal Pressure TEST = POWER CORD GND & LIVE & NEUTRAL
- LEAKAGE CURRENT: At 0.5mA

7. EYE-Q Check

- Step 1) Turn on the TV.
- Step 2) Press EYE button in adjust remote control.
- Step 3) Stay 6 seconds with Eye Q sensor hidden located on the front of the set.
- Step 4) Check the "Sensor Data" on the screen and check whether the value is lower than after 6 seconds, the value does not go below 10, Eye Q sensor is not working properly. Then, change the sensor.
- Step 5) Remove hand from the Eye Q II sensor and stay for 6 seconds.
- Step 6) Check whether the "Back Light (xxx)" value has risen on the screen. If after 6 seconds and the value still does not go high, the eye Q II sensor is not working properly. Replace the sensor.

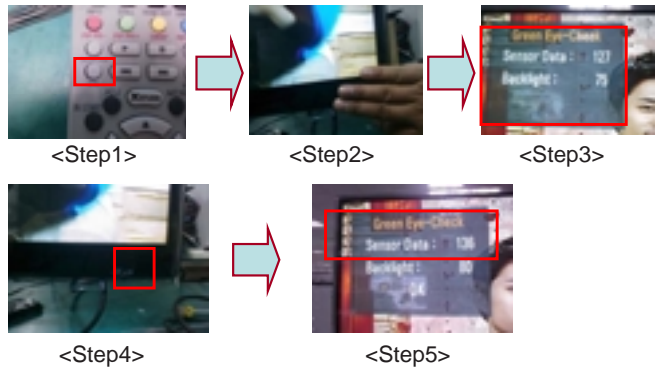

8. USB S/W Download (Option, Service only)

1. Put the USB Stick to the USB socket
2. Automatically detecting update file in USB Stick
 - If your downloaded program version in USB Stick is Low, it didn't work. But your downloaded version is High, USB data is automatically detecting
3. Show the message "Copying files from memory"

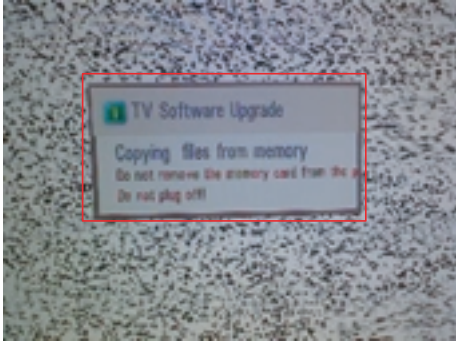

4. Updating is starting.

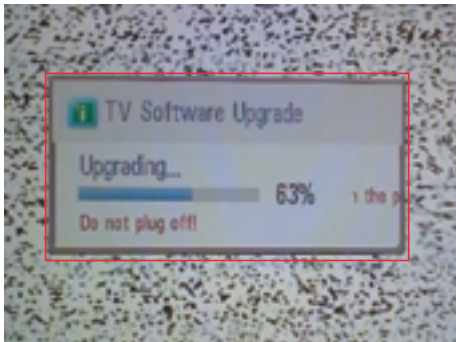

5. Updating Completed, The TV will restart automatically
6. If your TV is turned on, check your updated version and Tool option. (Explain the Tool option, next stage)

* If downloading version is more high than your TV have, TV can lost all channel data. In this case, you have to channel recover. if all channel data is cleared, you didn't have a DTV/ATV test on production line.

*** After downloading, have to adjust TOOL OPTION again.**

1. Push "IN-START" key in service remote controller.
2. Select "Tool Option 1" and Push "OK" button.
3. Punch in the number. (Each model has their number.)

EXPLODED VIEW

IMPORTANT SAFETY NOTICE

Many electrical and mechanical parts in this chassis have special safety-related characteristics. These parts are identified by ⚠ in the Schematic Diagram and EXPLODED VIEW. It is essential that these special safety parts should be replaced with the same components as recommended in this manual to prevent X-RADIATION, Shock, Fire, or other Hazards. Do not modify the original design without permission of manufacturer.

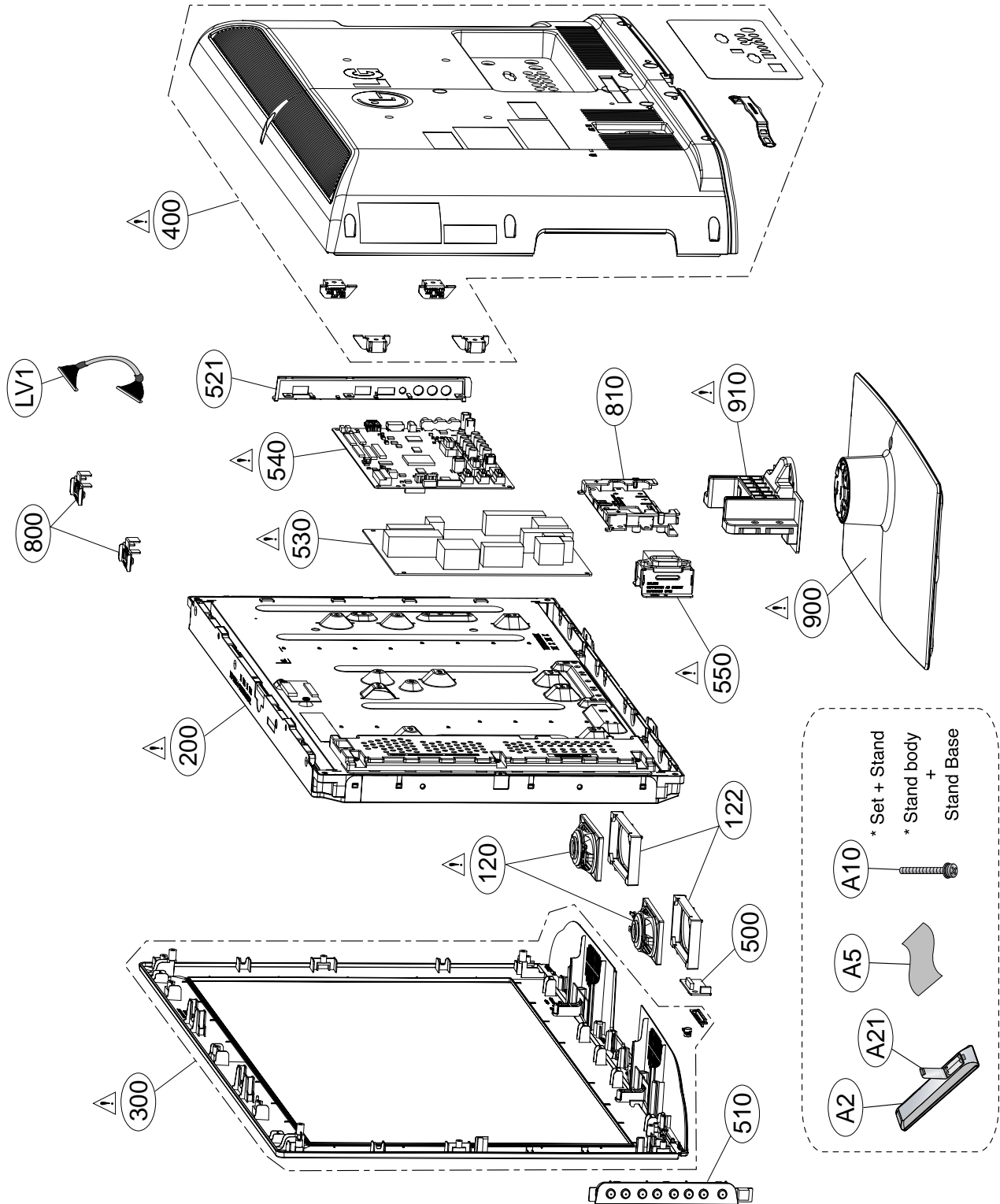

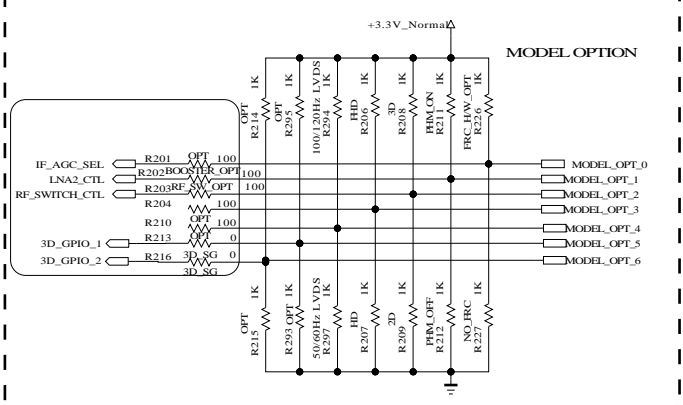

MODEL OPTION		PIN NAME		PIN NO.		LOW		HIGH	
MODEL_OPT_0	G19	NO_FRC	FRC_HW_OPT						
MODEL_OPT_4	E18	50/60Hz LVDS	100/120Hz LVDS						
MODEL_OPT_1	C5	PWM_OFF	PWM_ON						
MODEL_OPT_2	F7	2D	3D						
MODEL_OPT_3	B6	HD	FHD						
MODEL_OPT_5	D18	Ready	default						
MODEL_OPT_6	F9	LCD	OLED						

NO_FRC : LOW LOW
 US_INTERNAL : HIGH LOW
 US_EXTERNALBOOT : HIGH HIGH
 reserved for FRC : LOW HIGH

--> This option is only applied in EU
 In case of NON_EU, default value set LOW.

--> In case of GP2, This port was used for GIP/NON_GIP

--> MODEL_OPT_5, MODEL_OPT_6
 : Only 3D_SG GPIO OUTPUT CONTROL

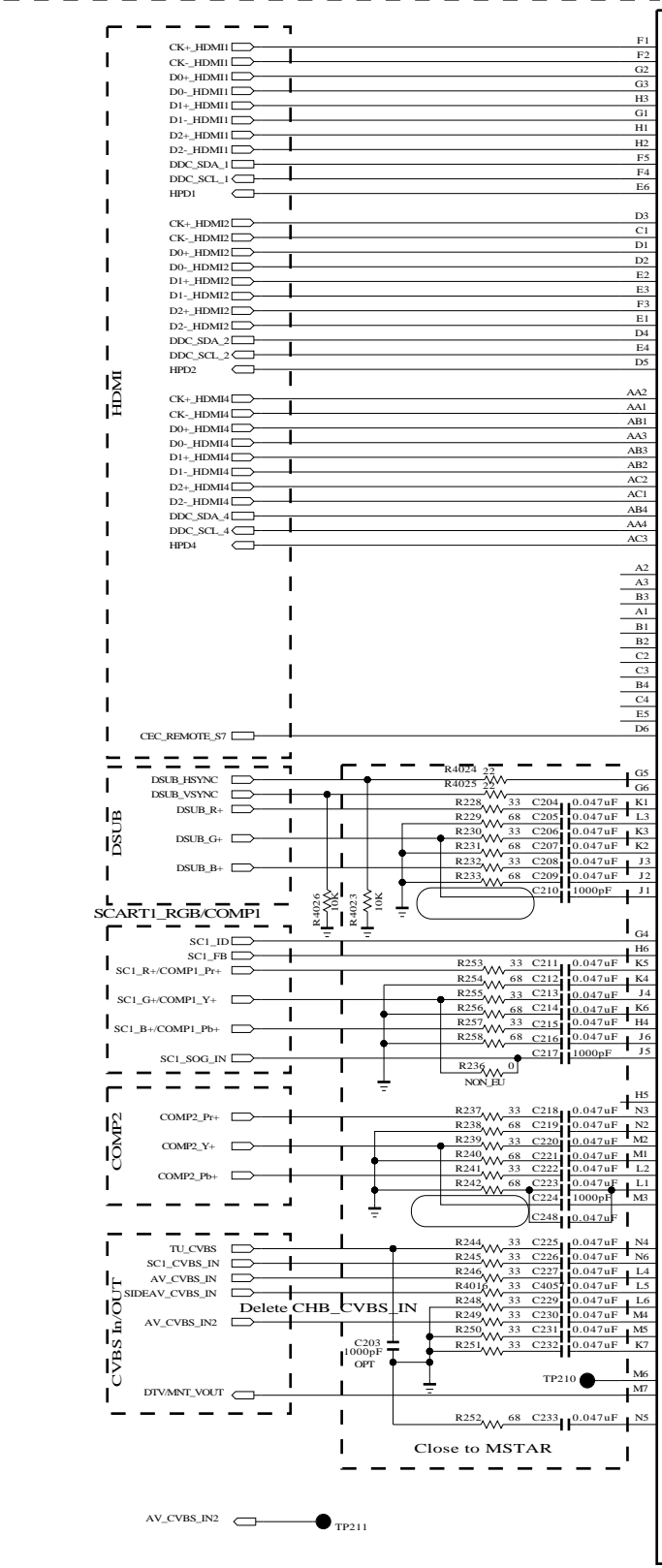
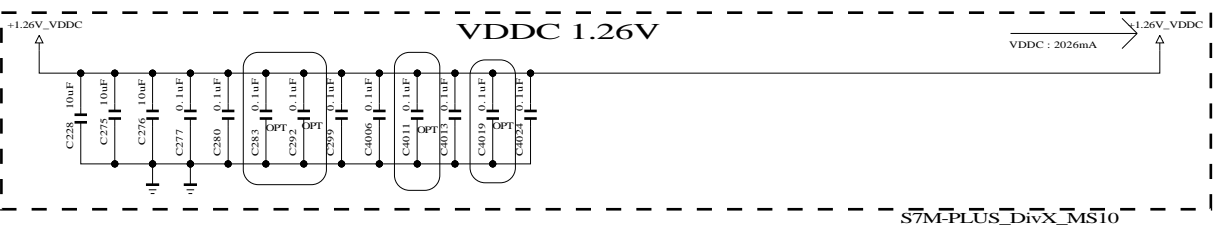
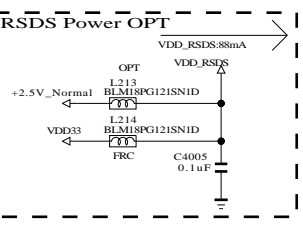

S7M-PLUS_DivX_MS10 IC101
 GE107DC-RP [S7M+ DIVX/MS10]

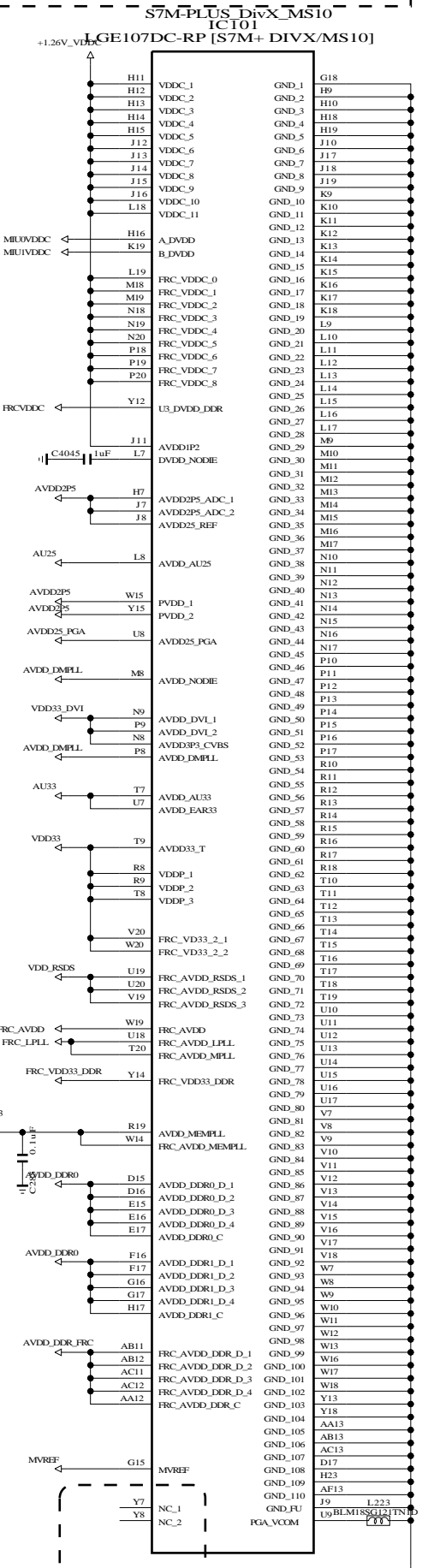
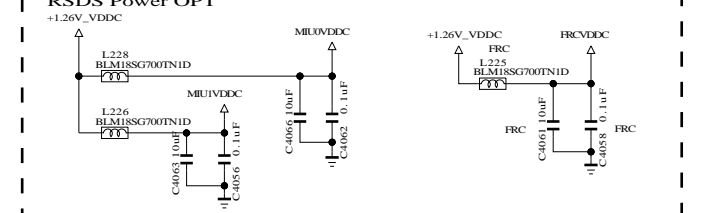
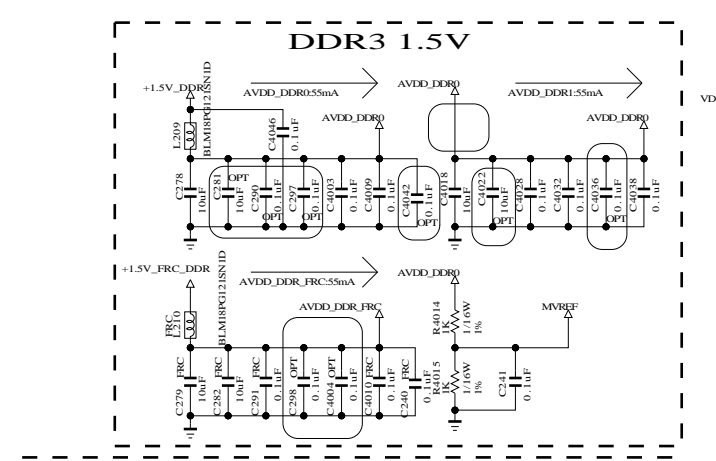
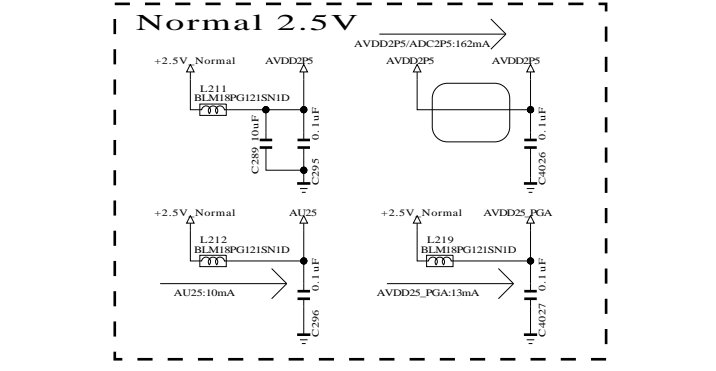
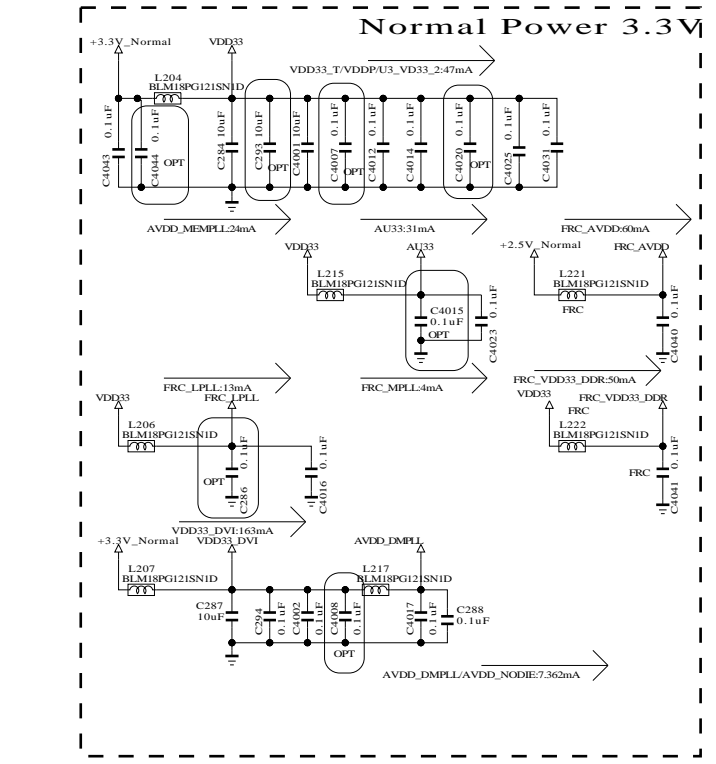
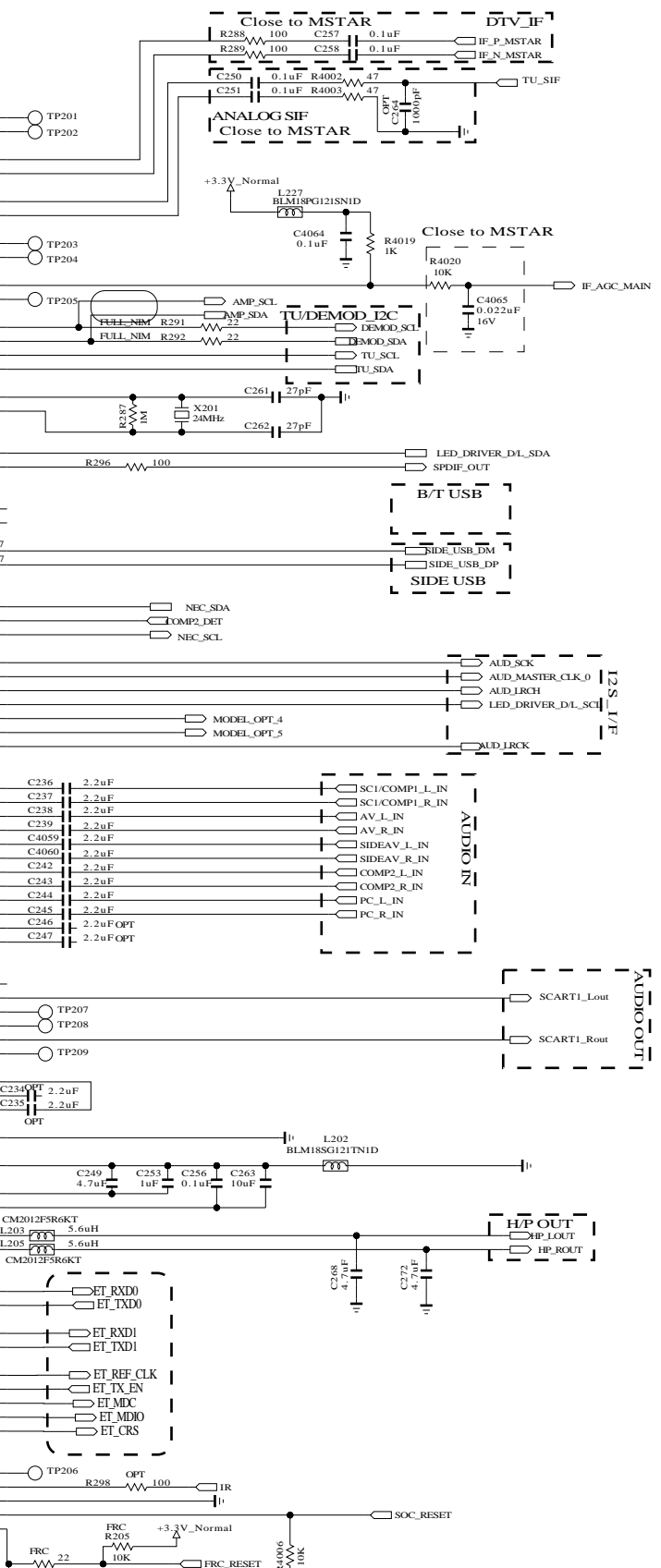

THE SYMBOL MARK OF THIS SCHEMATIC DIAGRAM INCORPORATES SPECIAL FEATURES IMPORTANT FOR PROTECTION FROM X-RADIATION. FILRE AND ELECTRICAL SHOCK HAZARDS, WHEN SERVICING IF IS ESSENTIAL THAT ONLY MANUFACTURES SPECIFIED PARTS BE USED FOR THE CRITICAL COMPONENTS IN THE SYMBOL MARK OF THE SCHEMATIC.

SECRET
 LGElectronics



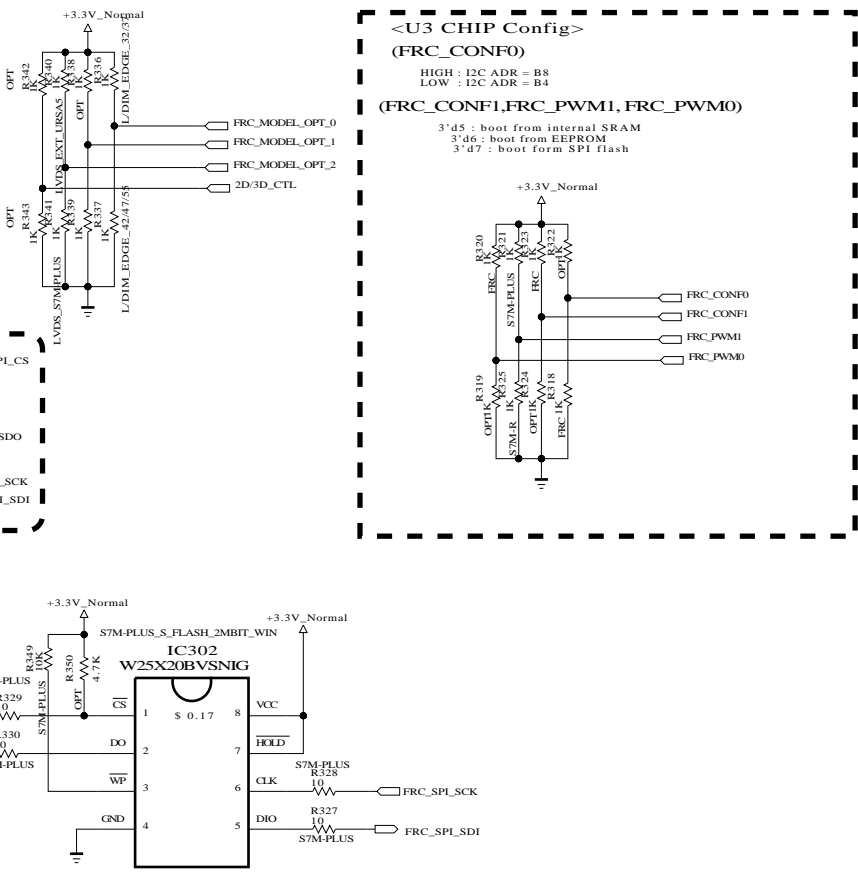
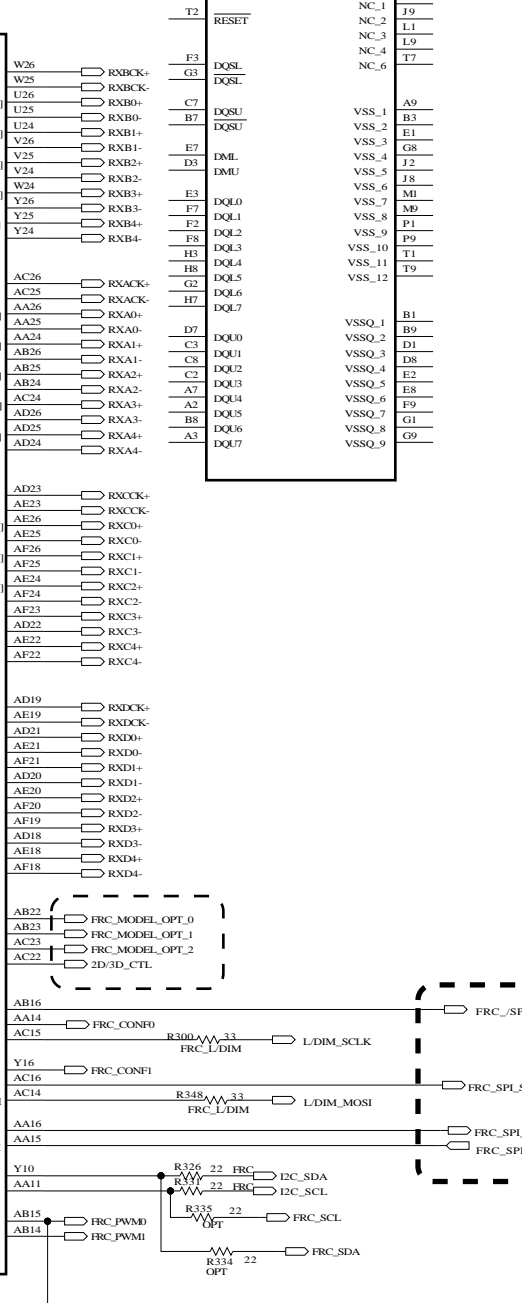
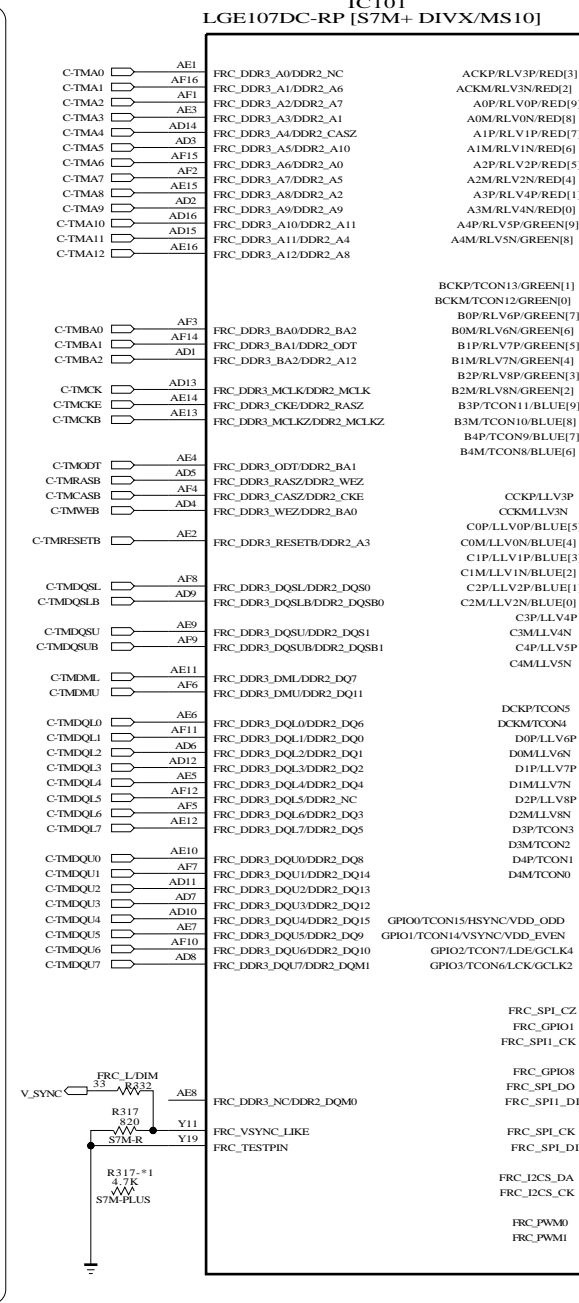
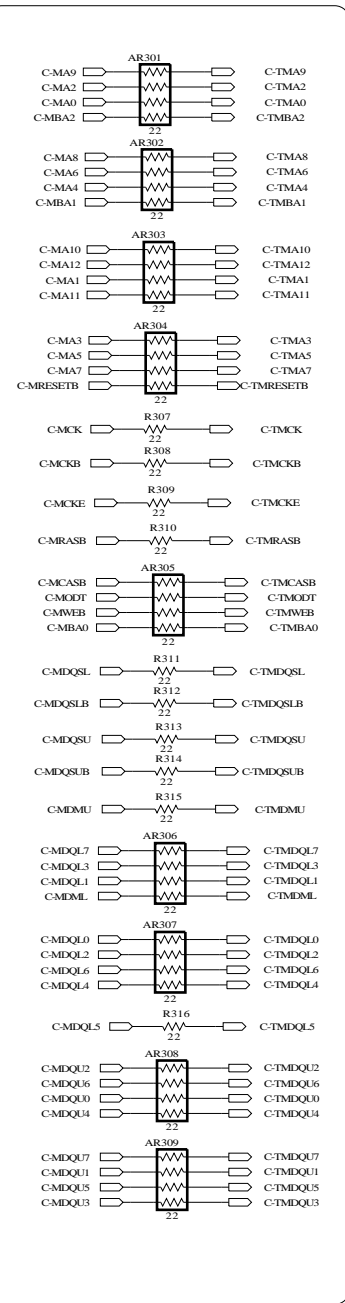
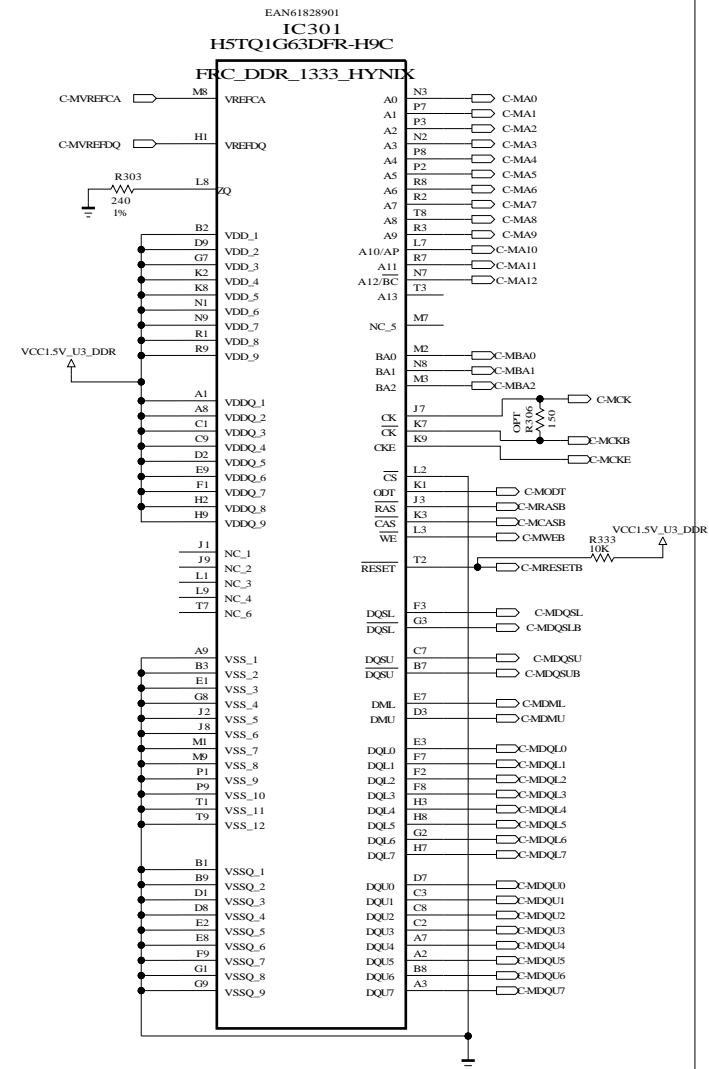
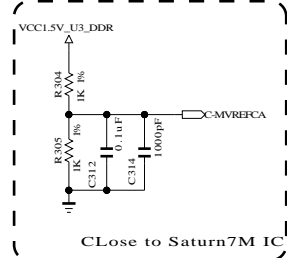
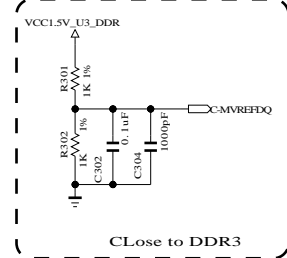
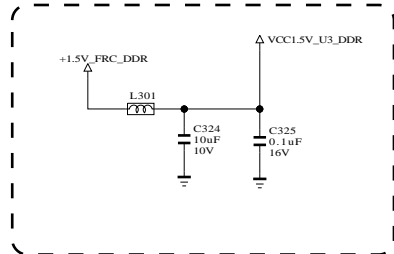
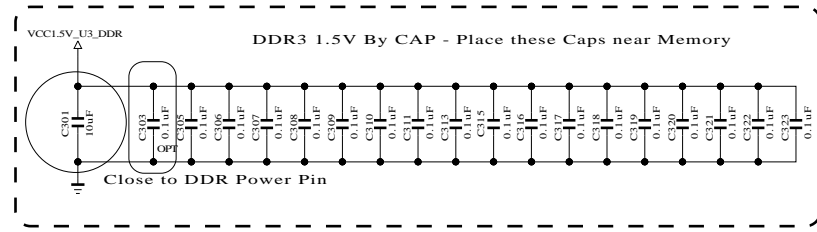

THE SYMBOL MARK OF THIS SCHEMATIC DIAGRAM INCORPORATES SPECIAL FEATURES IMPORTANT FOR PROTECTION FROM X-RADIATION. FILRE AND ELECTRICAL SHOCK HAZARDS, WHEN SERVICING IF IS ESSENTIAL THAT ONLY MANUFACTURES SPECIFIED PARTS BE USED FOR THE CRITICAL COMPONENTS IN THE SYMBOL MARK OF THE SCHEMATIC.

SECRET
LGElectronics

LG ELECTRONICS

MODEL BLOCK	GP2R FRC_DDR	DATE SHEET	20101023 3
-------------	-----------------	------------	---------------

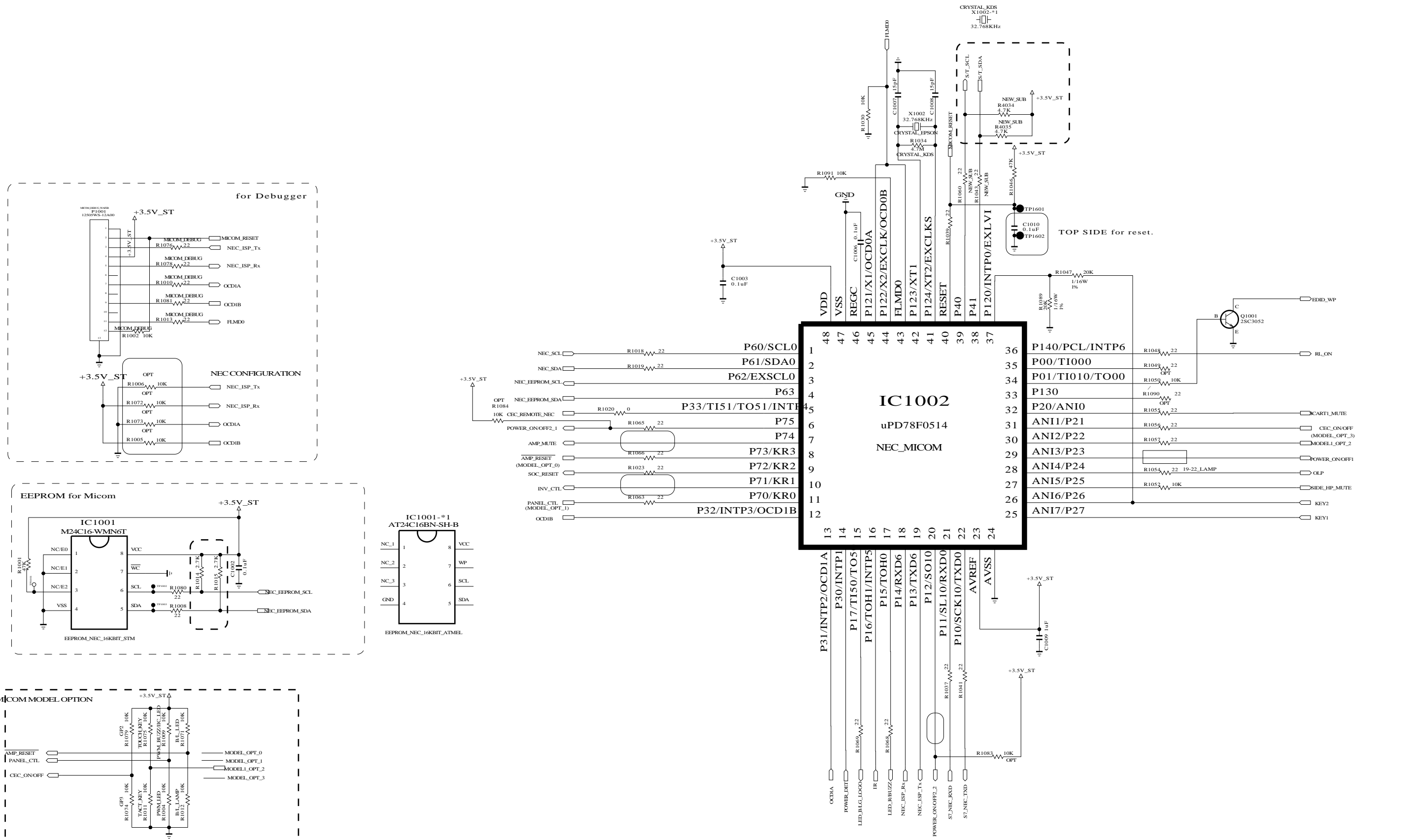

2011Y,GP2R, 101125 Update

MODEL OPTION				Description				
PIN NAME	PIN NO.	HIGH	LOW	MODEL_OPT_0	MODEL_OPT_1	MODEL_OPT_2	MODEL_OPT_3	
MODEL_OPT_0	8	B/L_LED	B/L_LAMP	LOW	LOW	LOW	LOW	LK330/LK430 for KR/US 10Y EVE-Q Sensor
MODEL_OPT_1	11	PWM_BUZZ/IC_LED	PWM_LED	LOW	LOW	LOW	HIGH	KEY & PWM LED & No Buzz & No LED Blink
MODEL_OPT_2	30	TOUCHKEY	TACT_KEY	LOW / LED HIGH / LAMP	HIGH	HIGH	LOW	LV25/LV35/LV45/LW45/LV55/LK45/LK55 S/T & IC LED & NO BUZZ & LED Blink
MODEL_OPT_3	31	GP2	GP3		HIGH	LOW	LOW	THD IIC LED(09Y IIC Protocol) & No BUZZ
				LOW	HIGH	LOW	LOW	THD S/T & IIC LED & No Buzz & LED Blink

PWM_BUZZ/IIC_LED : Using IIC for LED Breathing & PWM Buzz
 PWM_LED : Using PWM Signal for LED Lighting

2010Y,GP2

MODEL OPTION				MODEL_OPT_0	MODEL_OPT_1	MODEL_OPT_2	MODEL_OPT_3	
PIN NAME	PIN NO.	HIGH	LOW					
MODEL_OPT_0	8	B/L_LED	B/L_LAMP	LOW	LOW	LOW	LOW	LD350/450/550 PWM LED & No Buzz & No LED Blink
MODEL_OPT_1	11	PWM_BUZZ/IC_LED	PWM_LED	HIGH	LOW	HIGH	LOW	19/22/26LE5300/5300 IIC LED & PWM IIC BUZZ
MODEL_OPT_2	30	TOUCHKEY	TACT_KEY	HIGH	HIGH	HIGH	LOW	32/37/42/47/55LE5300 IIC LED & PWM BUZZ
MODEL_OPT_3	31	GPIO_LED	NON_GPIO_LED	LOW	HIGH	LOW	LOW	LD420 IIC LED(09Y IIC Protocol) & No BUZZ
				HIGH	LOW	LOW	HIGH	LE7300 GPIO LED & NO BUZZ

PWM_BUZZ/IIC_LED : For model that use LED Lighting used IIC
 PWM_LED : For model that use LED Lighting used PWM Signal

THE SYMBOL MARK OF THIS SCHEMATIC DIAGRAM INCORPORATES SPECIAL FEATURES IMPORTANT FOR PROTECTION FROM X-RADIATION. FILRE AND ELECTRICAL SHOCK HAZARDS, WHEN SERVICING IF IS ESSENTIAL THAT ONLY MANUFACTURES SPECIFIED PARTS BE USED FOR THE CRITICAL COMPONENTS IN THE SYMBOL MARK OF THE SCHEMATIC.

SECRET
LGElectronics

LG ELECTRONICS

MODEL	GP2R	DATE	20101125
BLOCK	MICOM Rev.4	SHEET	5 /

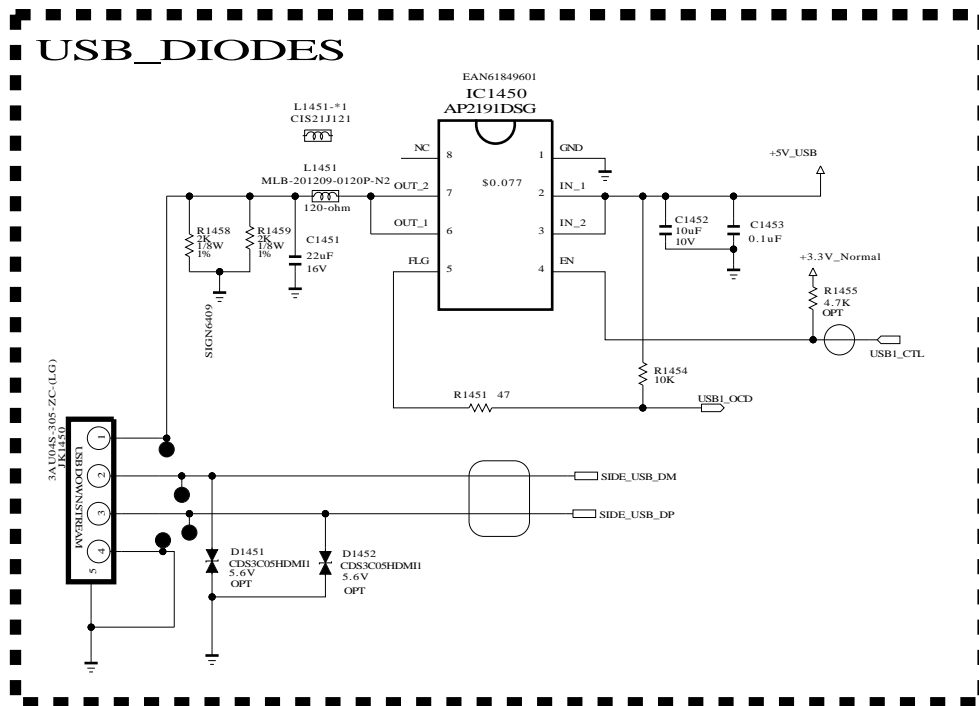

THE SYMBOL MARK OF THIS SCHEMATIC DIAGRAM INCORPORATES SPECIAL FEATURES IMPORTANT FOR PROTECTION FROM X-RADIATION. FILRE AND ELECTRICAL SHOCK HAZARDS, WHEN SERVICING IF IS ESSENTIAL THAT ONLY MANUFACTURES SPECIFIED PARTS BE USED FOR THE CRITICAL COMPONENTS IN THE SYMBOL MARK OF THE SCHEMATIC.

SECRET
LGElectronics

LG ELECTRONICS

MODEL	GP2R	DATE	20101023
BLOCK	USB_OCP_DIODE	SHEET	7 /

RGB/SPDIF/PC/HP

New Item Development EARPHONE BLOCK

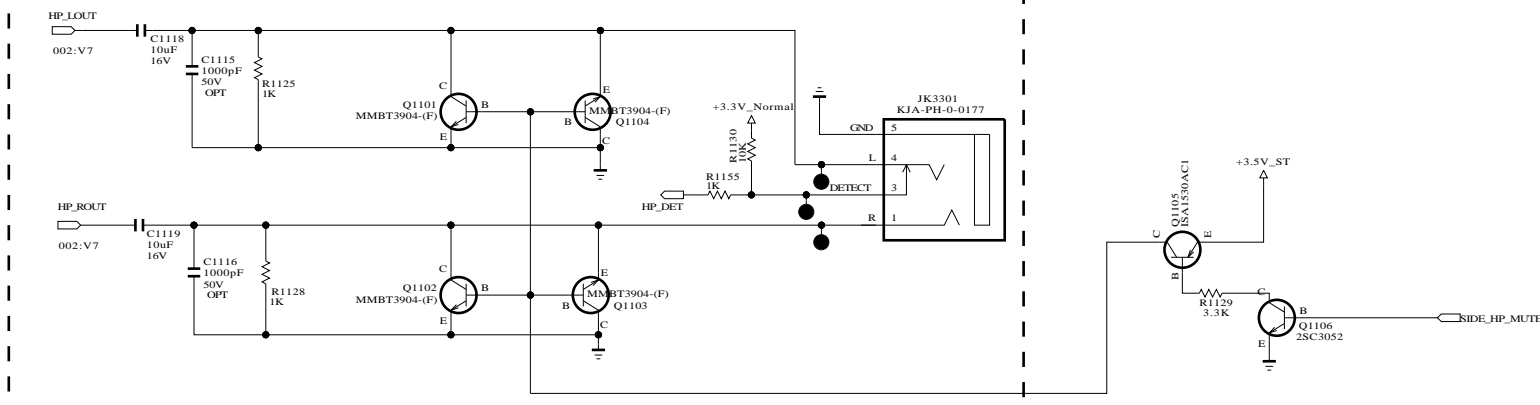

PC AUDIO

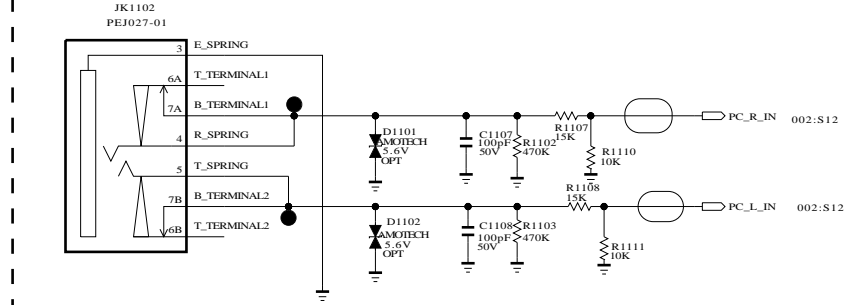

SPDIF OPTIC JACK

5.15 Mstar Circuit Application

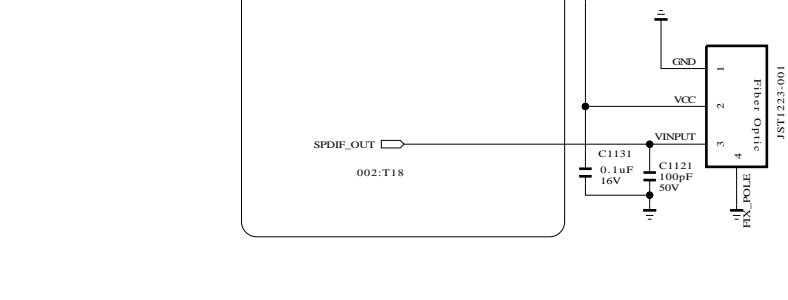

RGB PC

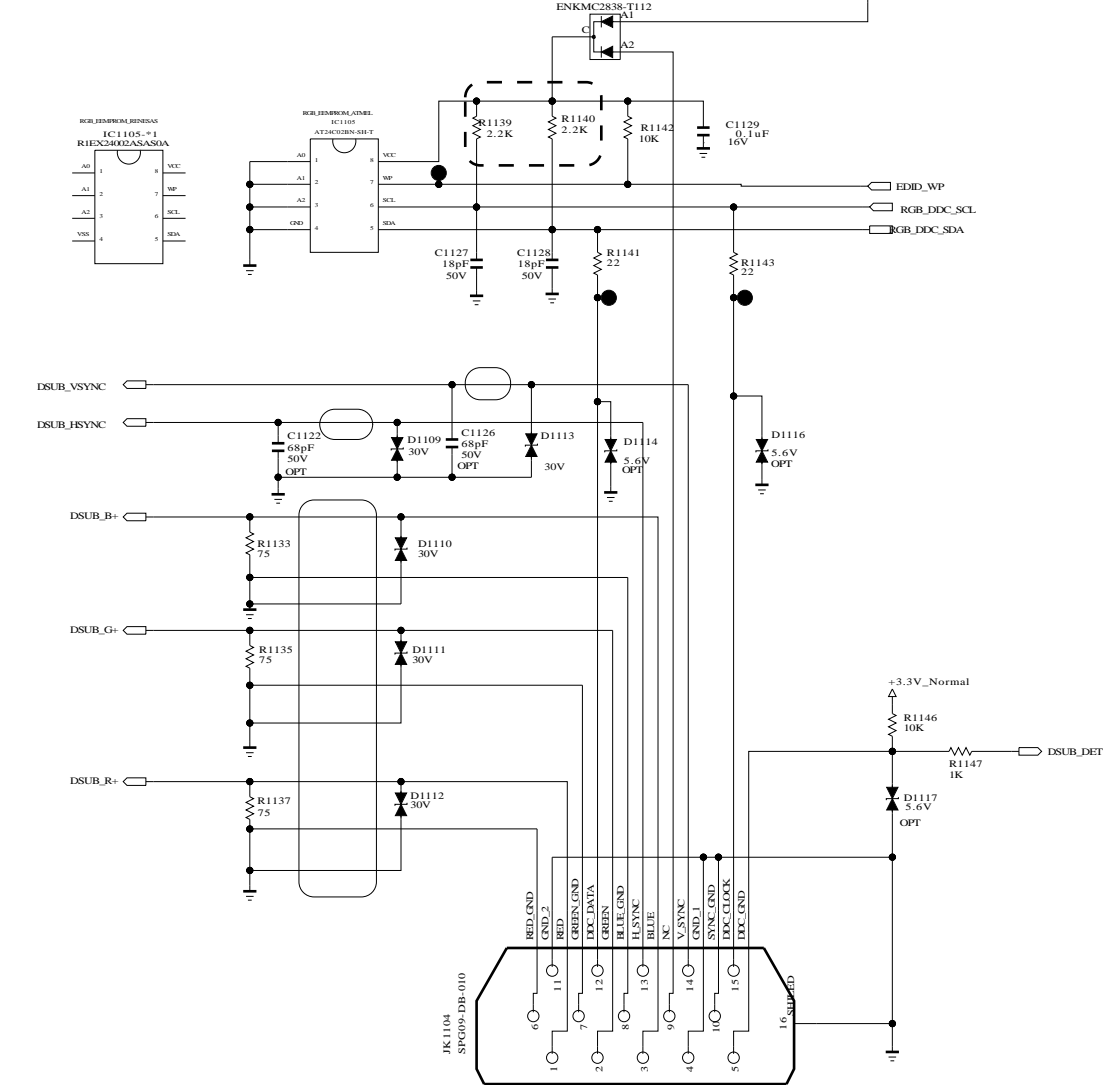

THE SYMBOL MARK OF THIS SCHEMATIC DIAGRAM INCORPORATES SPECIAL FEATURES IMPORTANT FOR PROTECTION FROM X-RADIATION. FILRE AND ELECTRICAL SHOCK HAZARDS, WHEN SERVICING IF IS ESSENTIAL THAT ONLY MANUFACTURES SPECIFIED PARTS BE USED FOR THE CRITICAL COMPONENTS IN THE SYMBOL MARK OF THE SCHEMATIC.

SECRET
LGElectronics

LG ELECTRONICS

MODEL	GP2R	DATE	20101023
BLOCK	RGB/SPDIF/HP	SHEET	9 /

RS232C

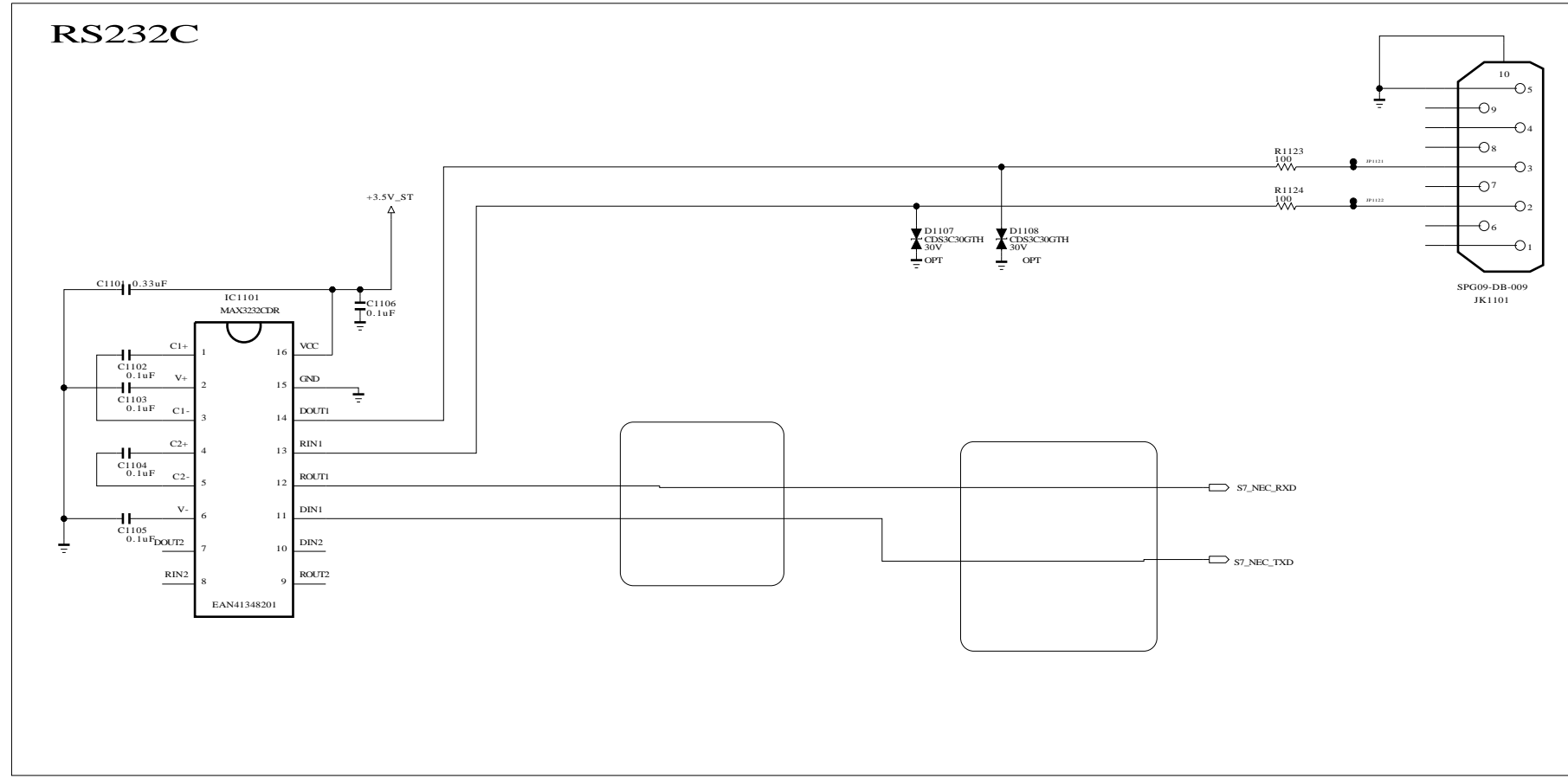

THE SYMBOL MARK OF THIS SCHEMATIC DIAGRAM INCORPORATES SPECIAL FEATURES IMPORTANT FOR PROTECTION FROM X-RADIATION. FILRE AND ELECTRICAL SHOCK HAZARDS, WHEN SERVICING IF IS ESSENTIAL THAT ONLY MANUFACTURES SPECIFIED PARTS BE USED FOR THE CRITICAL COMPONENTS IN THE SYMBOL MARK OF THE SCHEMATIC.

SECRET
LGElectronics



MODEL	GP2R	DATE	20101023
BLOCK	RS232C_9PIN	SHEET	10 /

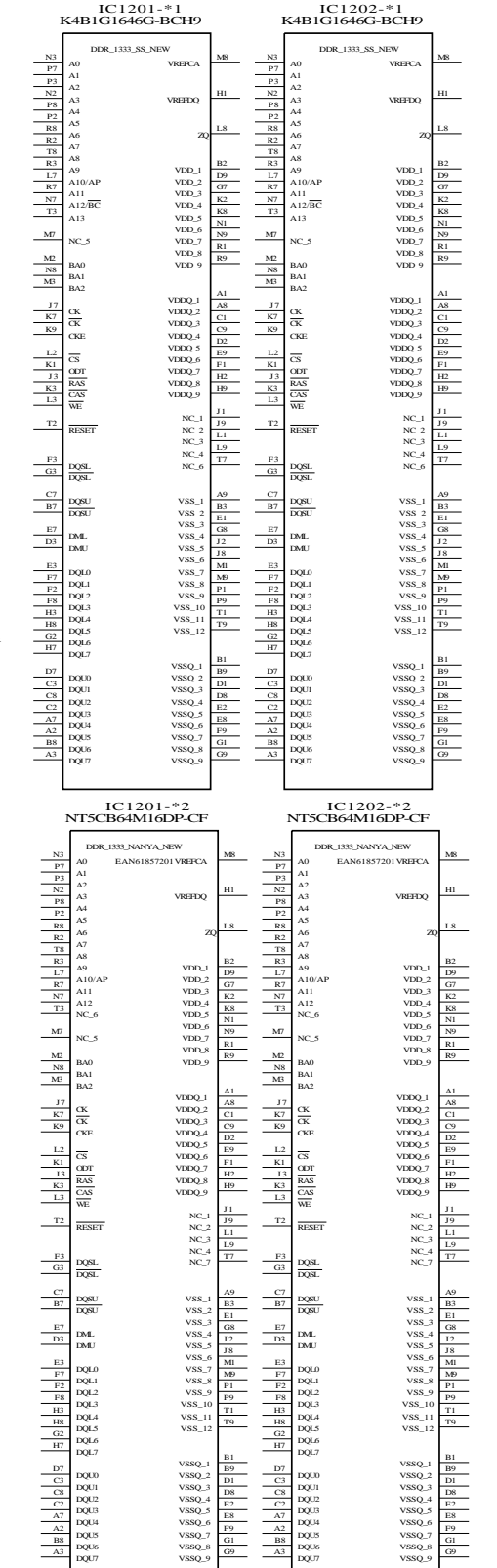
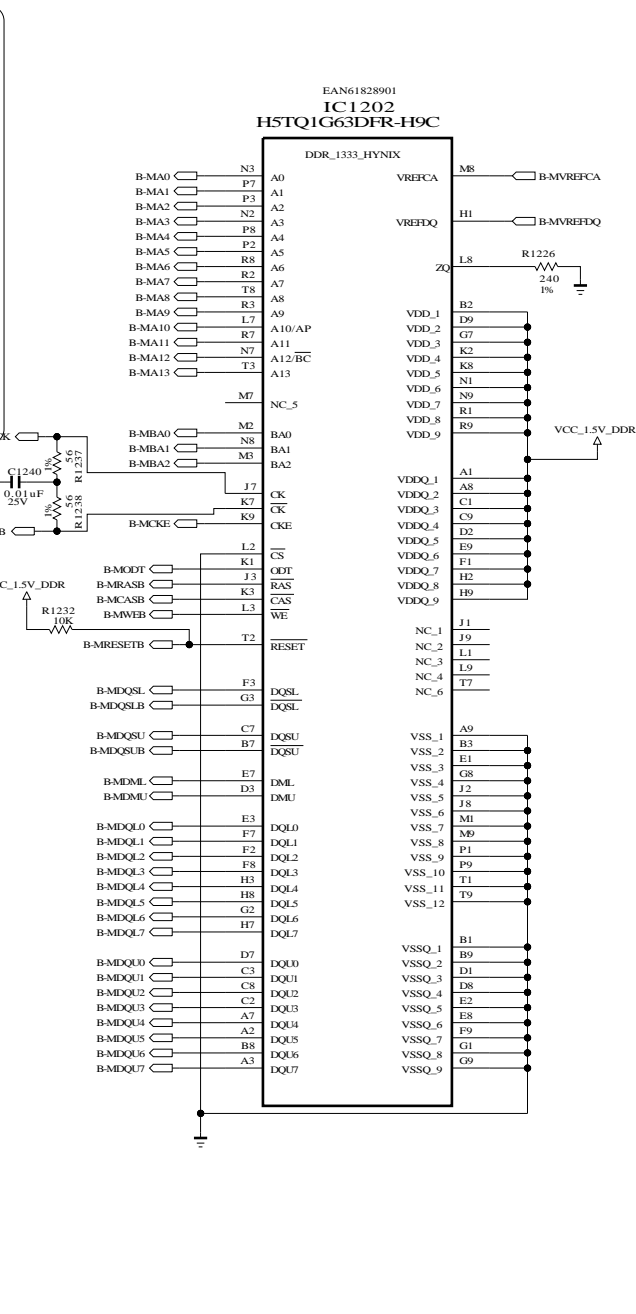
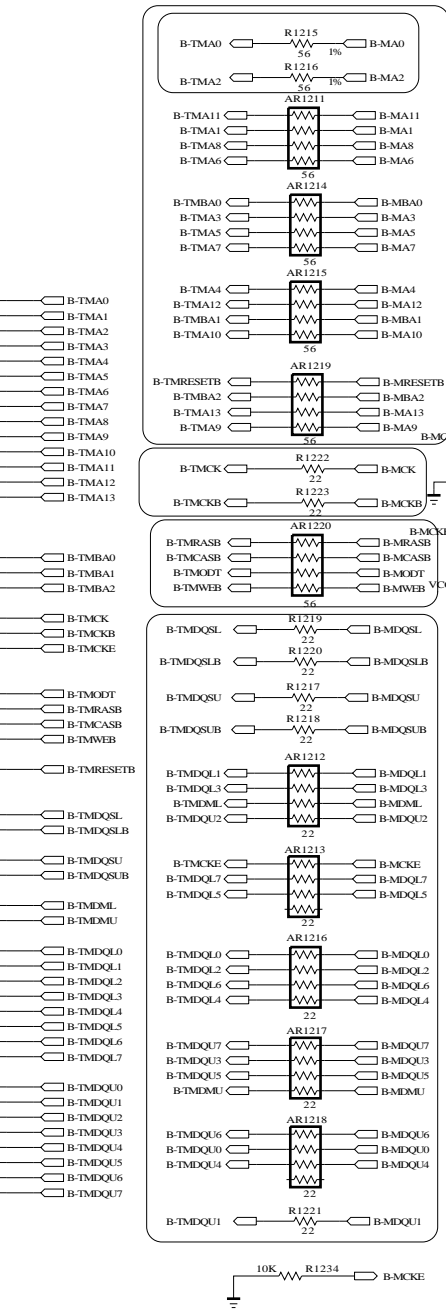
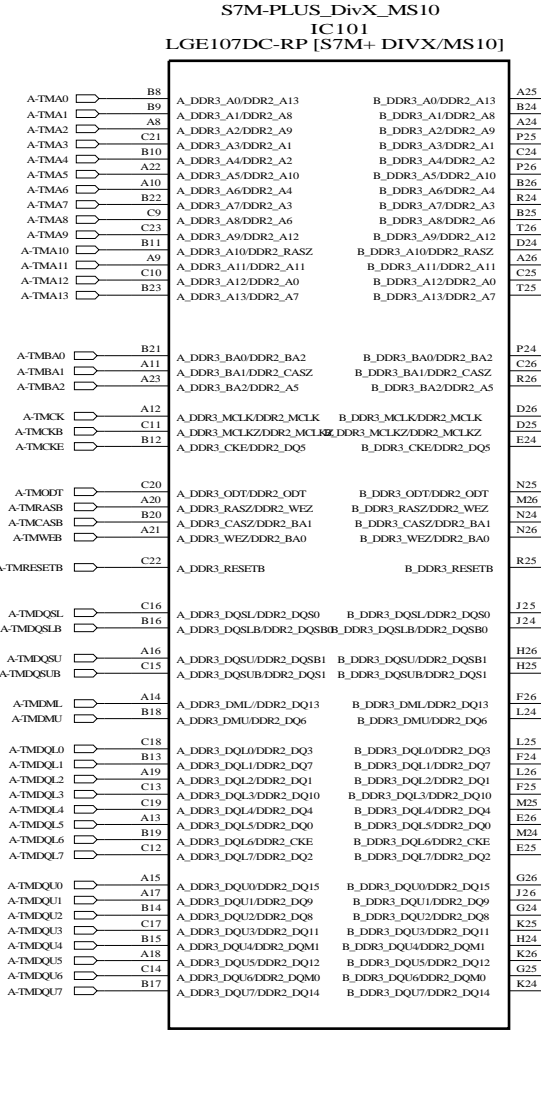
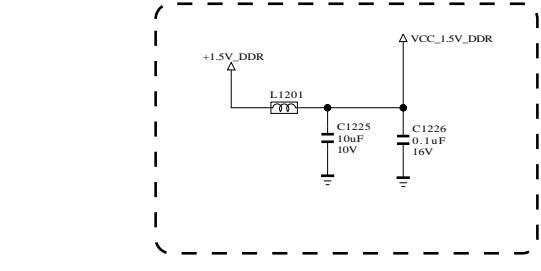
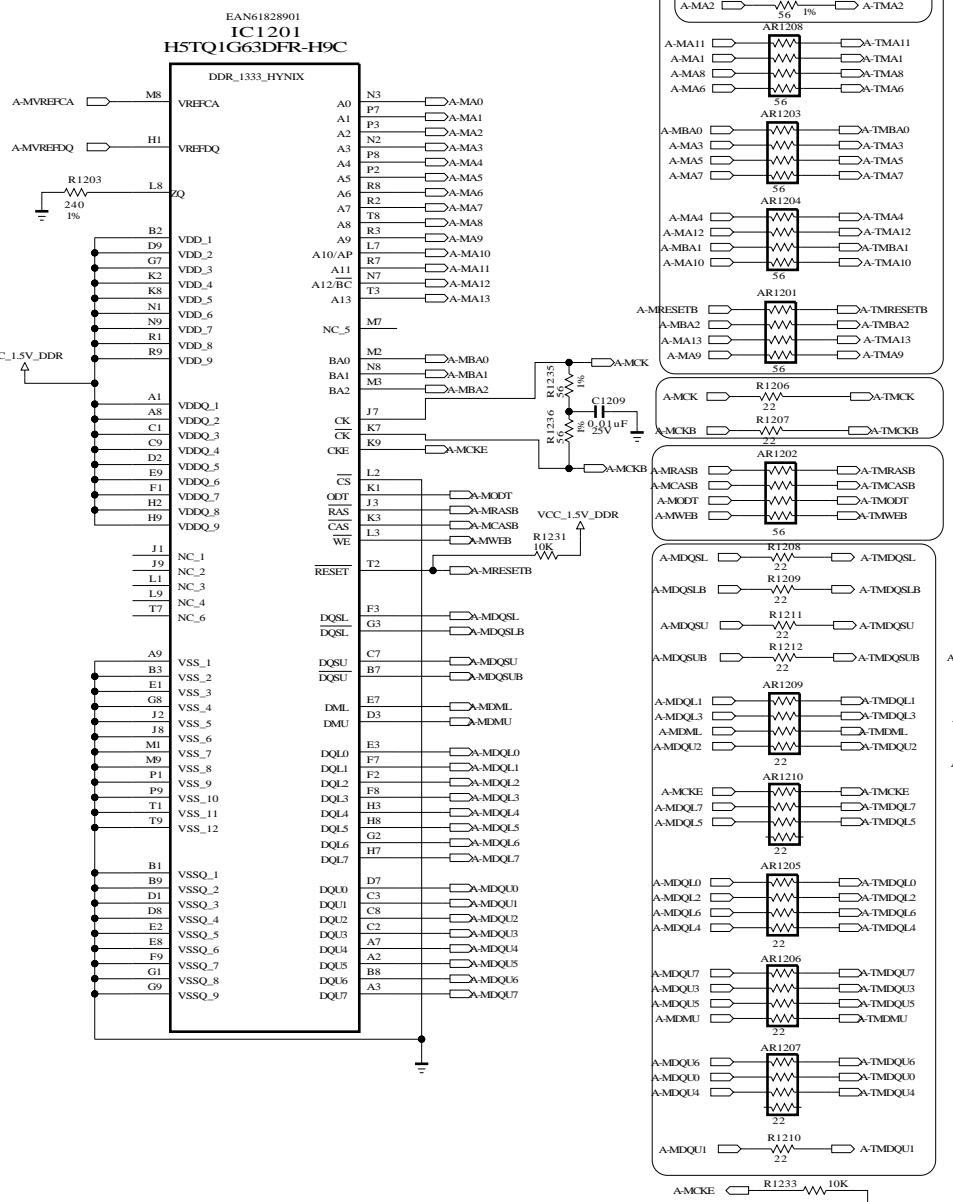
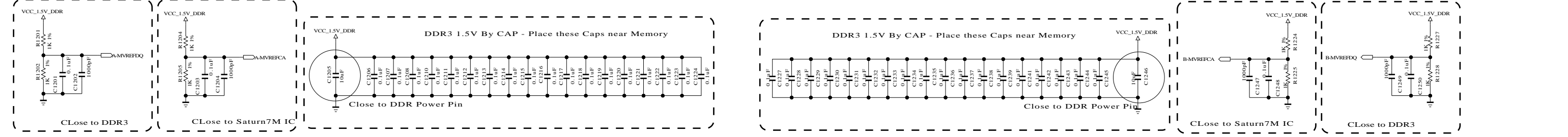

THE SYMBOL MARK OF THIS SCHEMATIC DIAGRAM INCORPORATES SPECIAL FEATURES IMPORTANT FOR PROTECTION FROM X-RADIATION. FILRE AND ELECTRICAL SHOCK HAZARDS, WHEN SERVICING IF IS ESSENTIAL THAT ONLY MANUFACTURES SPECIFIED PARTS BE USED FOR THE CRITICAL COMPONENTS IN THE SYMBOL MARK OF THE SCHEMATIC.

SECRET
LGElectronics



MODEL GP2R DATE 20101023
BLOCK DDR_256 SHEET 12 /

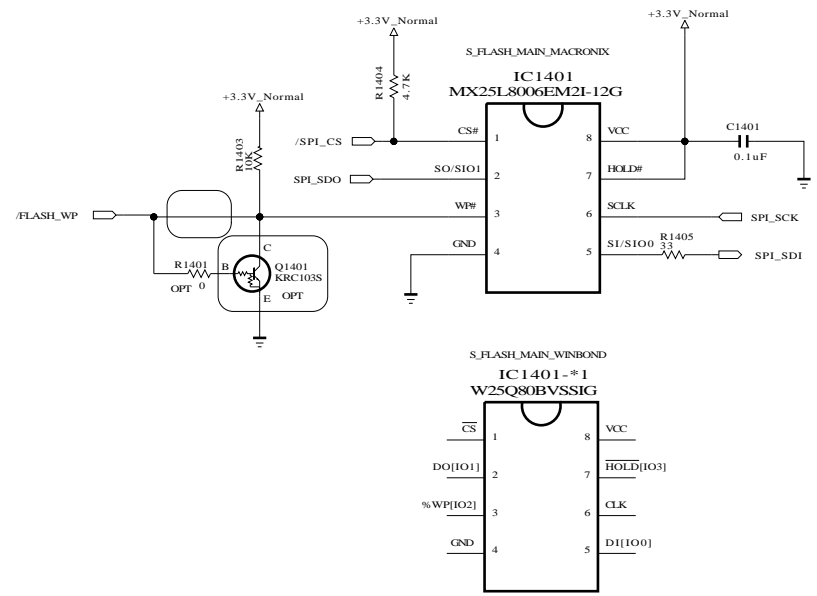

THE SYMBOL MARK OF THIS SCHEMATIC DIAGRAM INCORPORATES SPECIAL FEATURES IMPORTANT FOR PROTECTION FROM X-RADIATION. FILRE AND ELECTRICAL SHOCK HAZARDS, WHEN SERVICING IF IS ESSENTIAL THAT ONLY MANUFACTURES SPECIFIED PARTS BE USED FOR THE CRITICAL COMPONENTS IN THE SYMBOL MARK OF THE SCHEMATIC.

SECRET
LGElectronics



MODEL	GP2R	DATE	20101023
BLOCKS	FLASH 1MB	SHEET	13 /

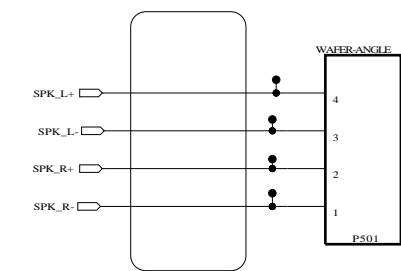
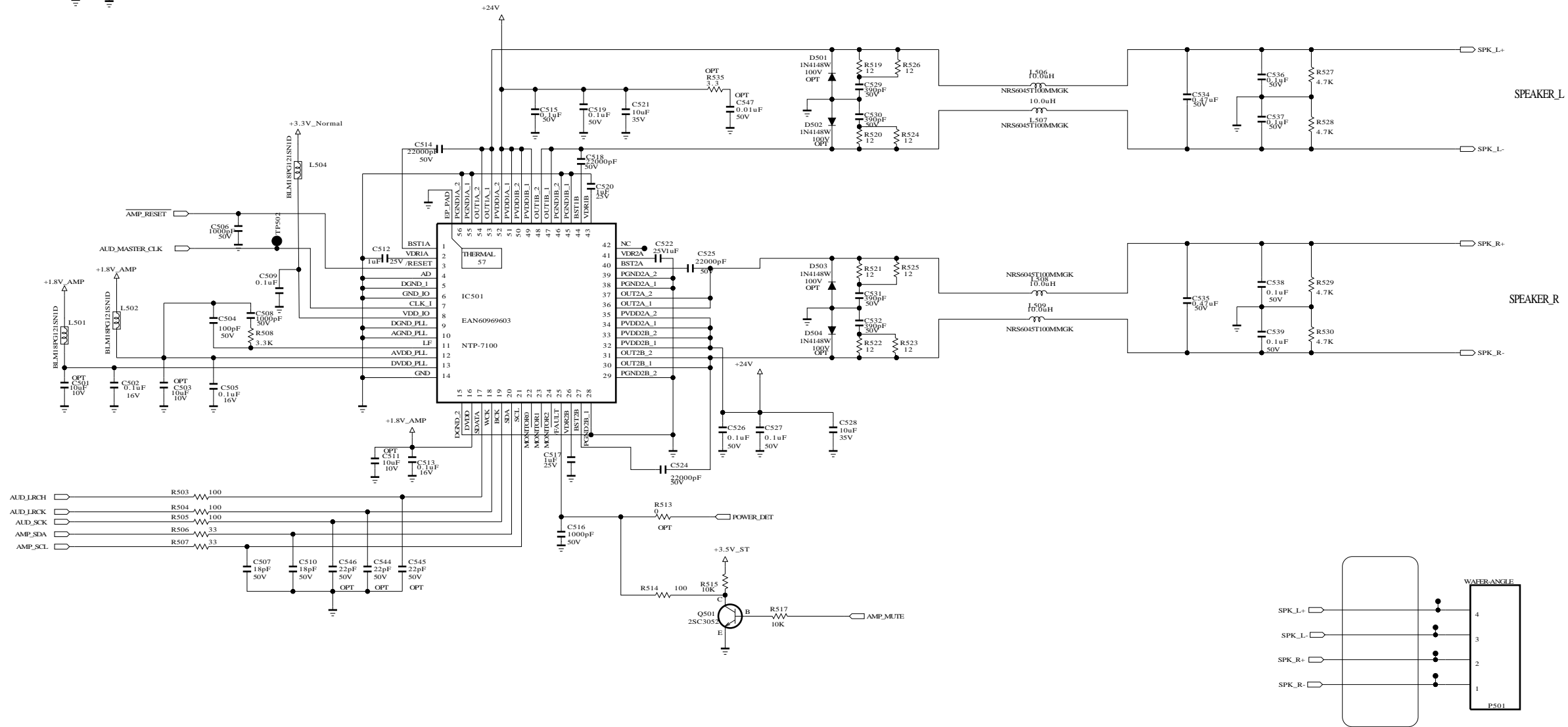
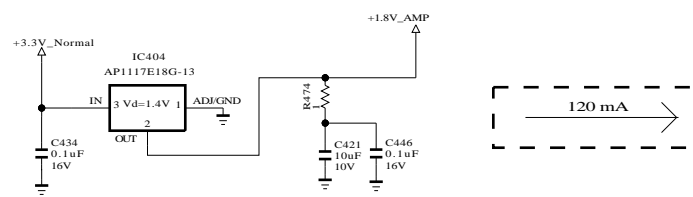

THE SYMBOL MARK OF THIS SCHEMATIC DIAGRAM INCORPORATES SPECIAL FEATURES IMPORTANT FOR PROTECTION FROM X-RADIATION. FILRE AND ELECTRICAL SHOCK HAZARDS, WHEN SERVICING IF IS ESSENTIAL THAT ONLY MANUFACTURES SPECIFIED PARTS BE USED FOR THE CRITICAL COMPONENTS IN THE SYMBOL MARK OF THE SCHEMATIC.

SECRET
LGElectronics

LG ELECTRONICS

MODEL	GP2R	DATE	20101023
BLOCK	AMP NTP	SHEET	16 /

Rear AV

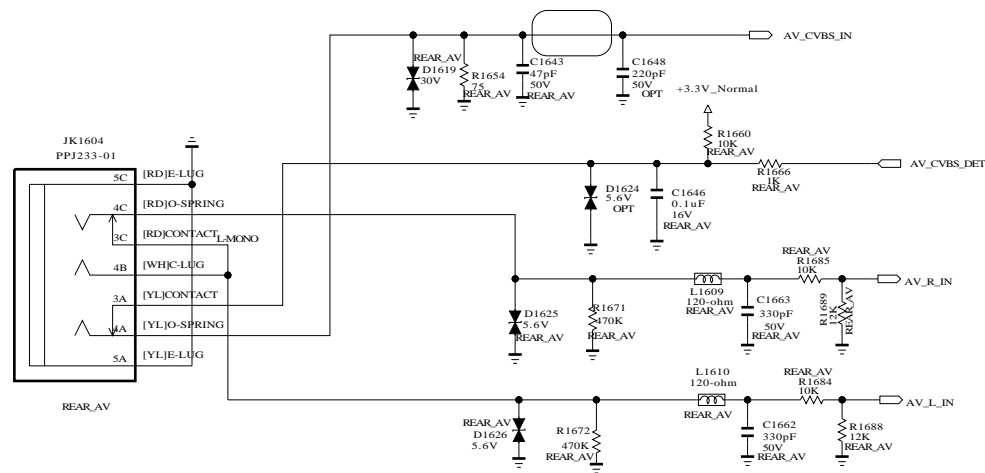

COMPONENT2

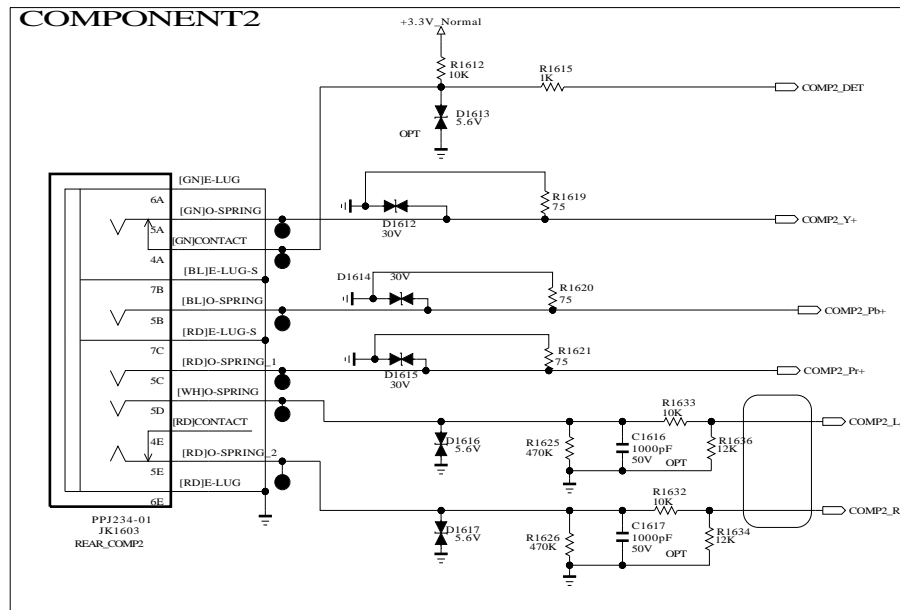

ETHERNET FOR DVB_T2

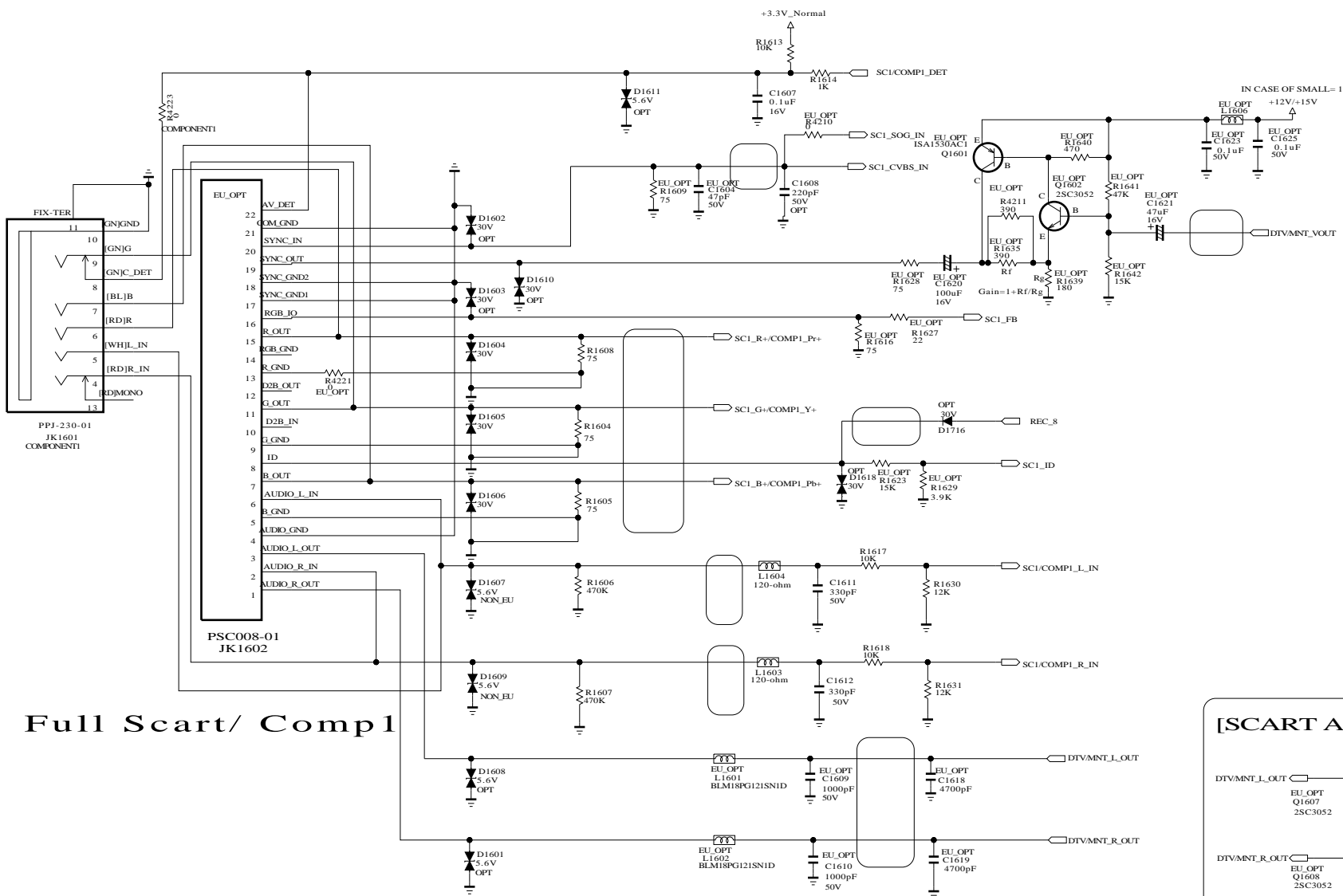
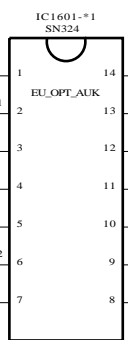
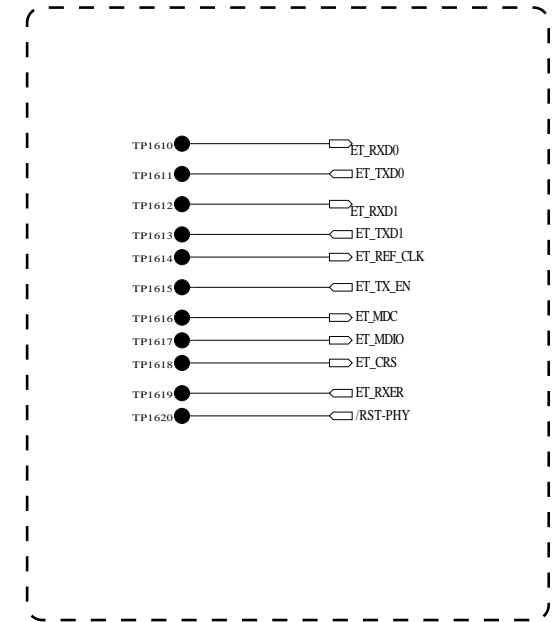

Full Scart/ Comp1

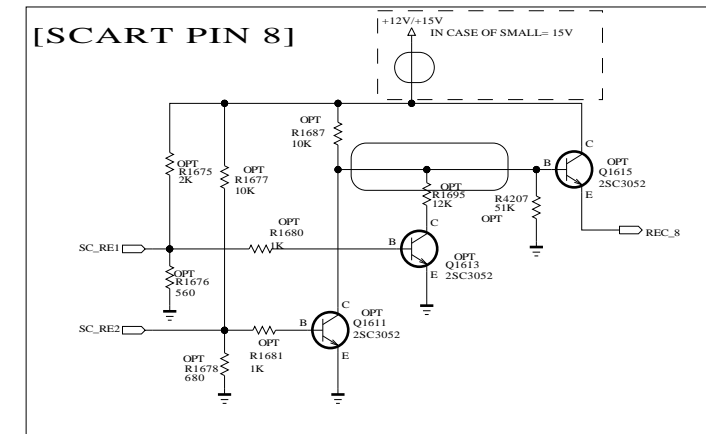
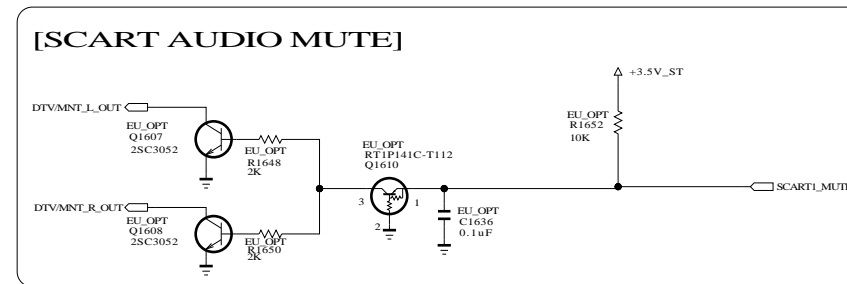
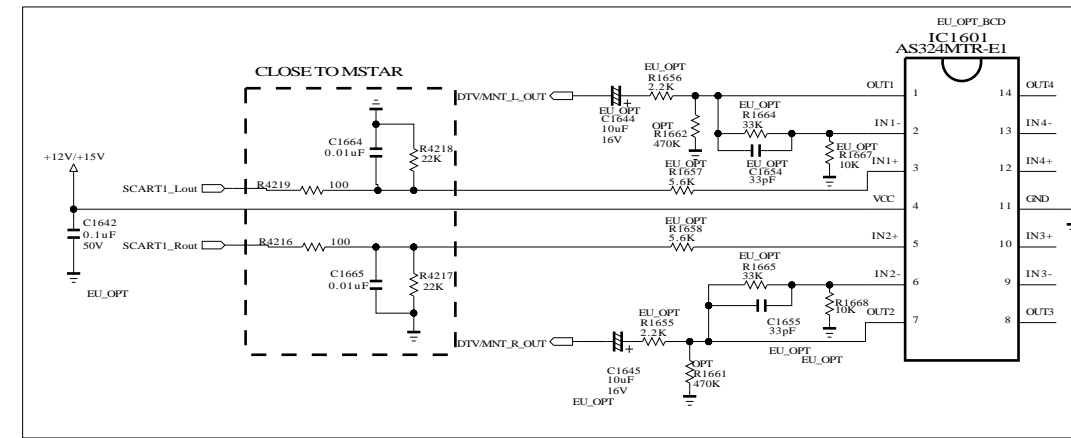

THE SYMBOL MARK OF THIS SCHEMATIC DIAGRAM INCORPORATES SPECIAL FEATURES IMPORTANT FOR PROTECTION FROM X-RADIATION. FILRE AND ELECTRICAL SHOCK HAZARDS, WHEN SERVICING IF IS ESSENTIAL THAT ONLY MANUFACTURES SPECIFIED PARTS BE USED FOR THE CRITICAL COMPONENTS IN THE SYMBOL MARK OF THE SCHEMATIC.

SECRET
LGElectronics

LG ELECTRONICS

MODEL	GP2R	DATE	20101023
BLOCK	REAR JACK	SHEET	17 /

**SIDE CVBS PHONE JACK
(New Item Development)**

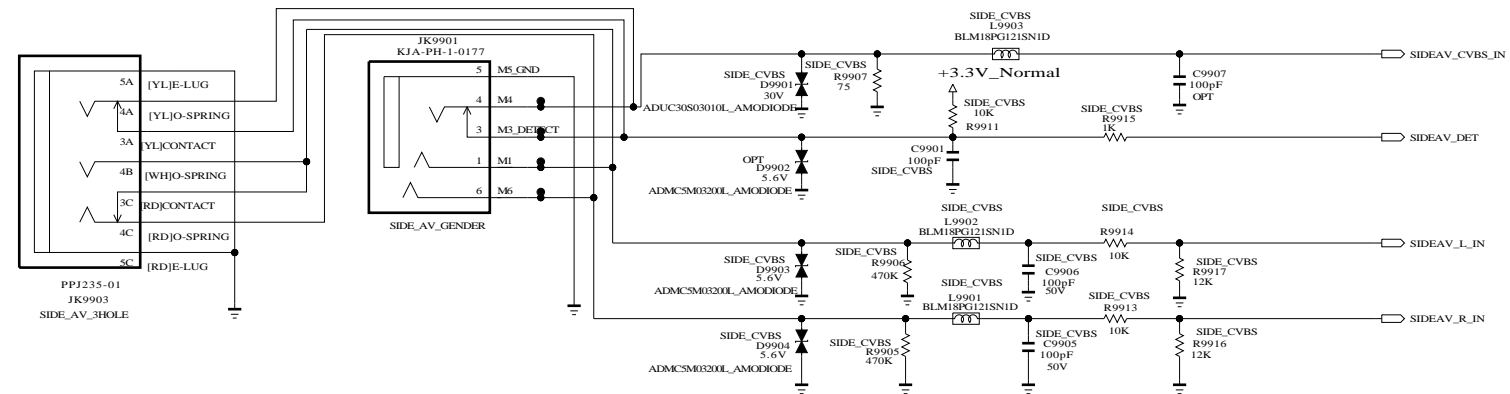

**SIDE COMPONENT PHONE JACK
(New Item Development)**

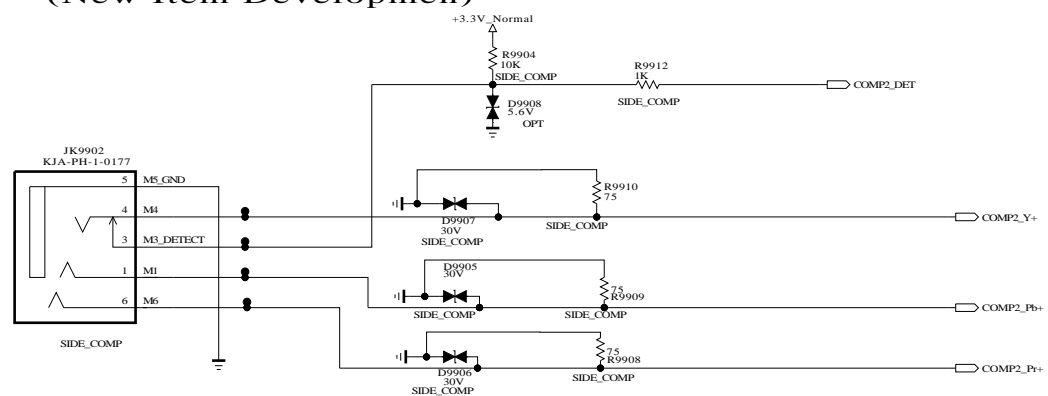

THE SYMBOL MARK OF THIS SCHEMATIC DIAGRAM INCORPORATES SPECIAL FEATURES IMPORTANT FOR PROTECTION FROM X-RADIATION. FILRE AND ELECTRICAL SHOCK HAZARDS, WHEN SERVICING IF IS ESSENTIAL THAT ONLY MANUFACTURES SPECIFIED PARTS BE USED FOR THE CRITICAL COMPONENTS IN THE SYMBOL MARK OF THE SCHEMATIC.

SECRET
LGElectronics



MODEL	GP2R	DATE	20101023
BLOCK	SIDE_JACK	SHEET	18 /

CI Region

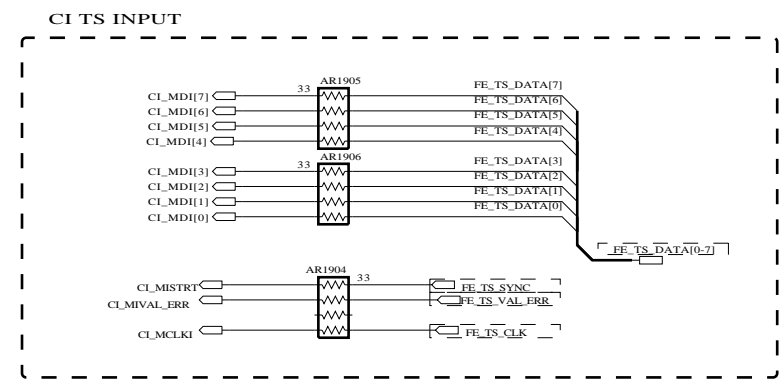
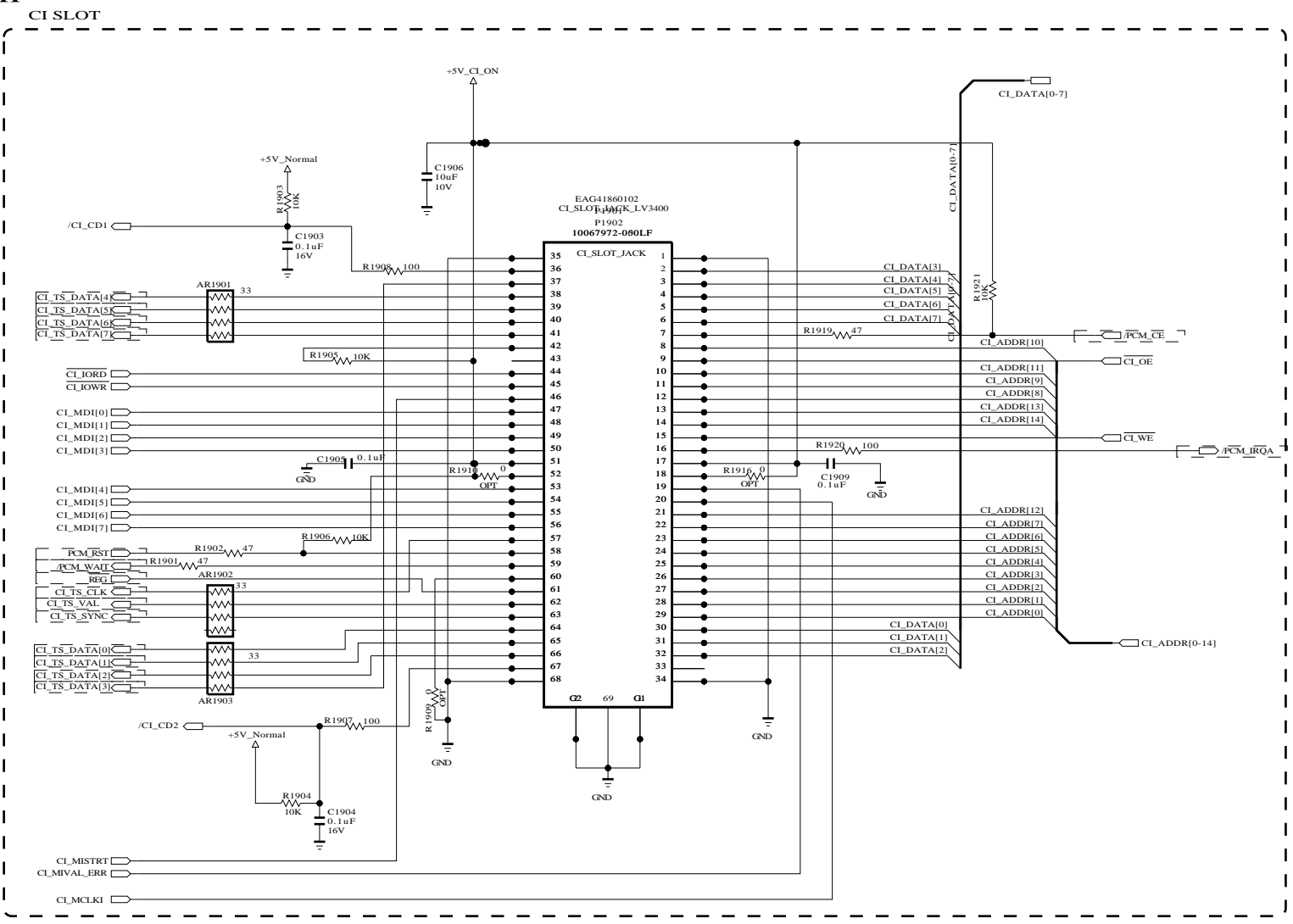

CI HOST I/F

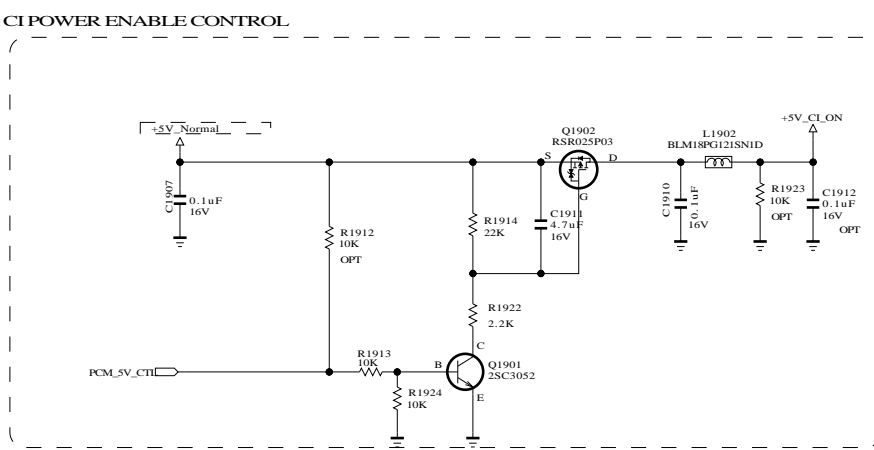
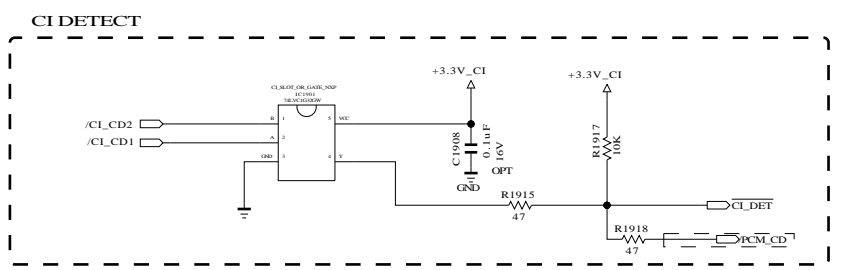
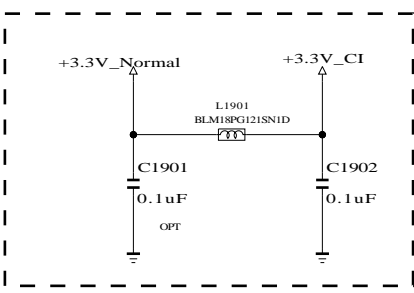
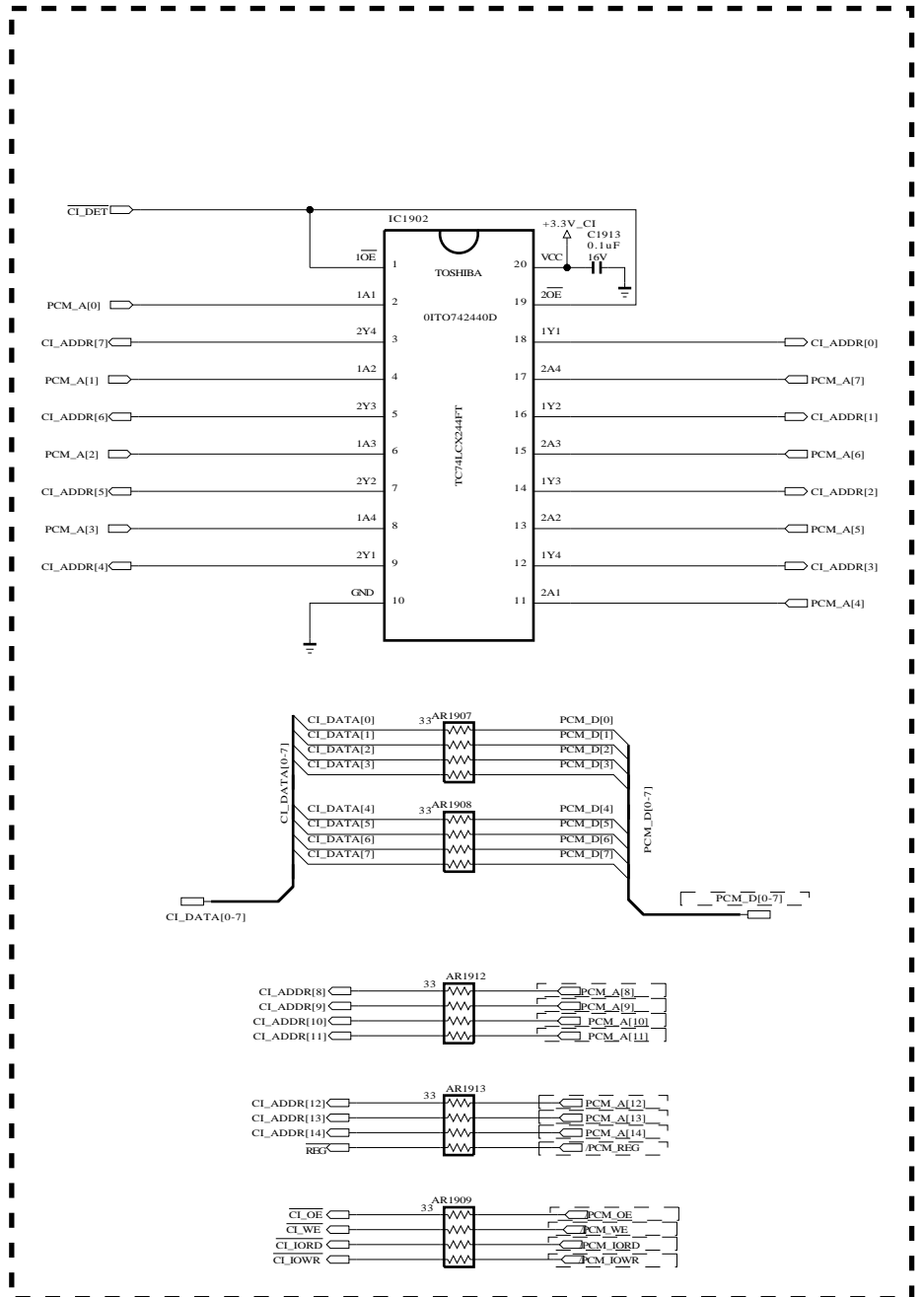

THE SYMBOL MARK OF THIS SCHEMATIC DIAGRAM INCORPORATES SPECIAL FEATURES IMPORTANT FOR PROTECTION FROM X-RADIATION. FILRE AND ELECTRICAL SHOCK HAZARDS, WHEN SERVICING IF IS ESSENTIAL THAT ONLY MANUFACTURES SPECIFIED PARTS BE USED FOR THE CRITICAL COMPONENTS IN THE SYMBOL MARK OF THE SCHEMATIC.

SECRET
LGElectronics



MODEL	GP2R	DATE	20101023
BLOCK	PCMC1	SHEET	20 /

CONTROL IR & LED

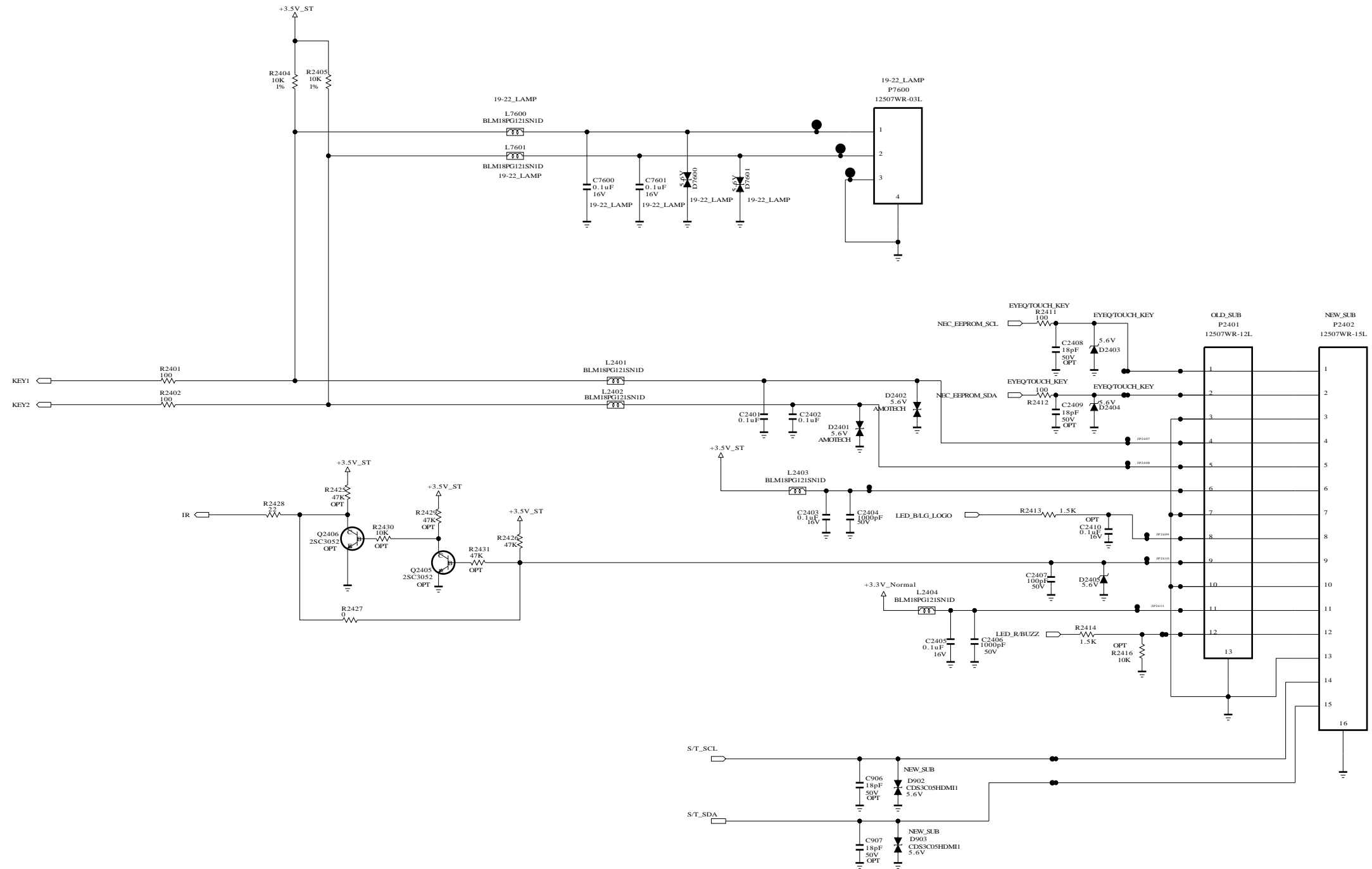

THE SYMBOL MARK OF THIS SCHEMATIC DIAGRAM INCORPORATES SPECIAL FEATURES IMPORTANT FOR PROTECTION FROM X-RADIATION. FILRE AND ELECTRICAL SHOCK HAZARDS, WHEN SERVICING IF IS ESSENTIAL THAT ONLY MANUFACTURES SPECIFIED PARTS BE USED FOR THE CRITICAL COMPONENTS IN THE SYMBOL MARK OF THE SCHEMATIC.

SECRET
LGElectronics



MODEL	GP2R	DATE	20101023
BLOCK/CONT_SMA		SHEET	23 /

[51Pin LVDS Connector]
(For FHD 60/120Hz)

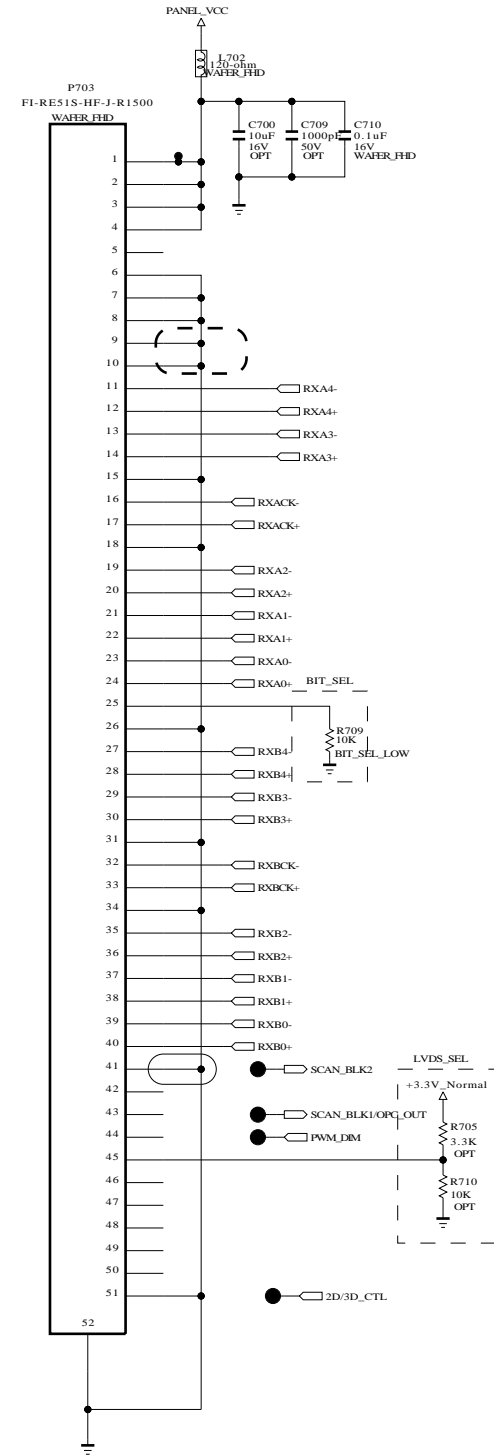

41PIN WAFER DELETE, HONGSU, 20101115

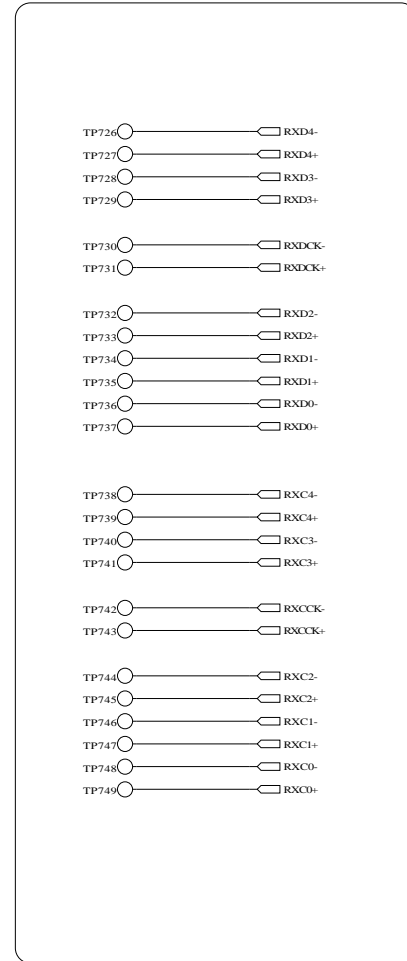

[30Pin LVDS Connector]
(For HD 60Hz_Normal)

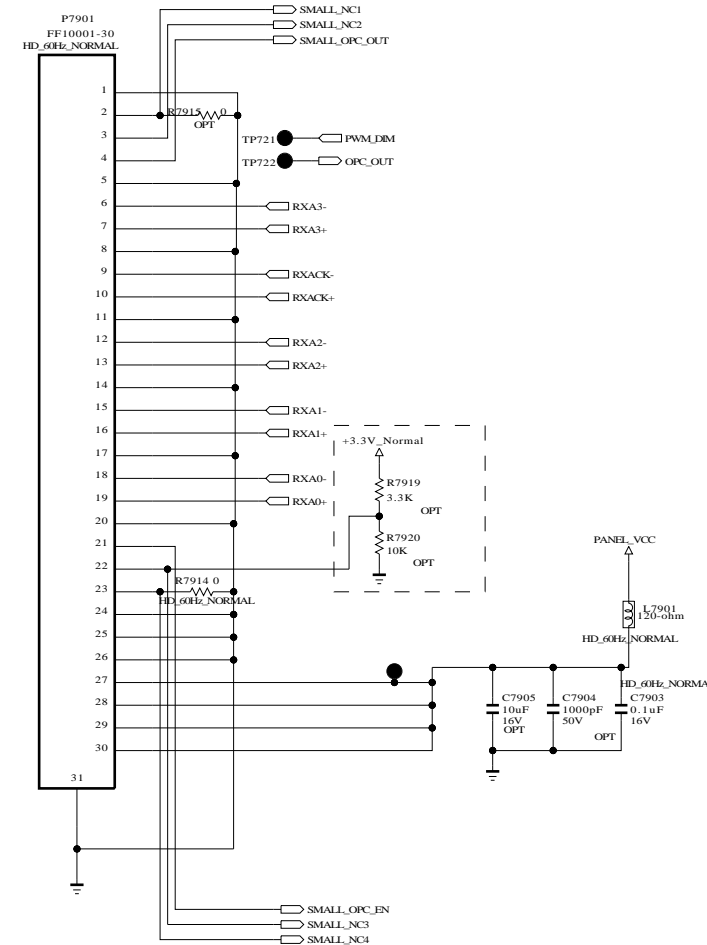

[30Pin LVDS Connector]
(For HD 60Hz_Small)

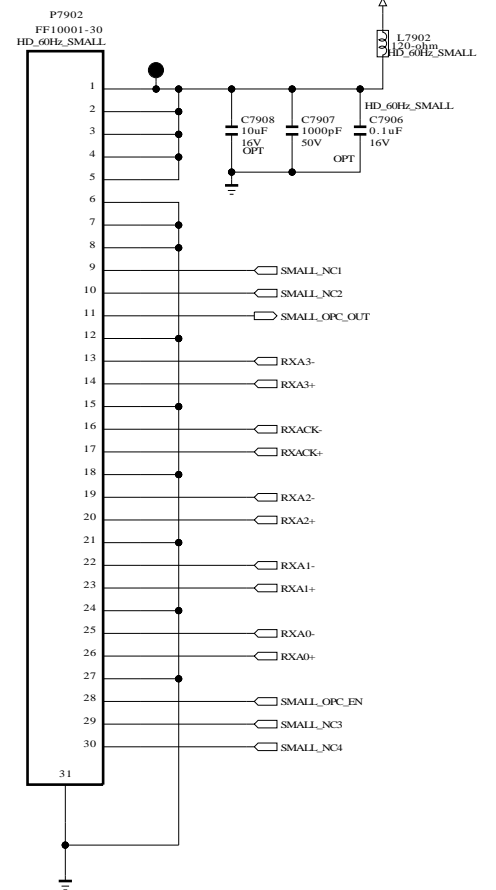

THE SYMBOL MARK OF THIS SCHEMATIC DIAGRAM INCORPORATES SPECIAL FEATURES IMPORTANT FOR PROTECTION FROM X-RADIATION. FILRE AND ELECTRICAL SHOCK HAZARDS, WHEN SERVICING IF IS ESSENTIAL THAT ONLY MANUFACTURES SPECIFIED PARTS BE USED FOR THE CRITICAL COMPONENTS IN THE SYMBOL MARK OF THE SCHEMATIC.

SECRET
LGElectronics

LG ELECTRONICS

MODEL	GP2R	DATE	20101115
BLOCK	LVDS_SMALL	SHEET	24 /

NON_L/DIM_LED/DRIVER

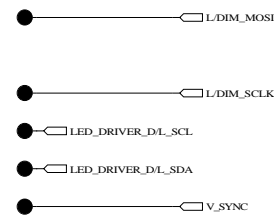

NON_3D_SG

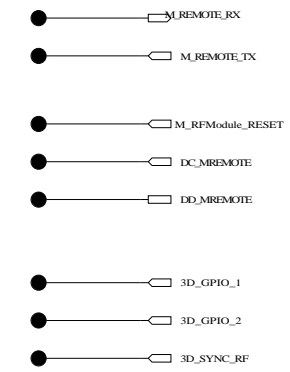

THE SYMBOL MARK OF THIS SCHEMATIC DIAGRAM INCORPORATES SPECIAL FEATURES IMPORTANT FOR PROTECTION FROM X-RADIATION, FILRE AND ELECTRICAL SHOCK HAZARDS, WHEN SERVICING IF IS ESSENTIAL THAT ONLY MANUFACTURES SPECIFIED PARTS BE USED FOR THE CRITICAL COMPONENTS IN THE SYMBOL MARK OF THE SCHEMATIC.

SECRET
LGElectronics

 LG ELECTRONICS

MODEL	GP2R	DATE	20101023
BLOCK	NON_L/DIM	SHEET	26 /



Trouble shooting guide

1. Power-up boot check

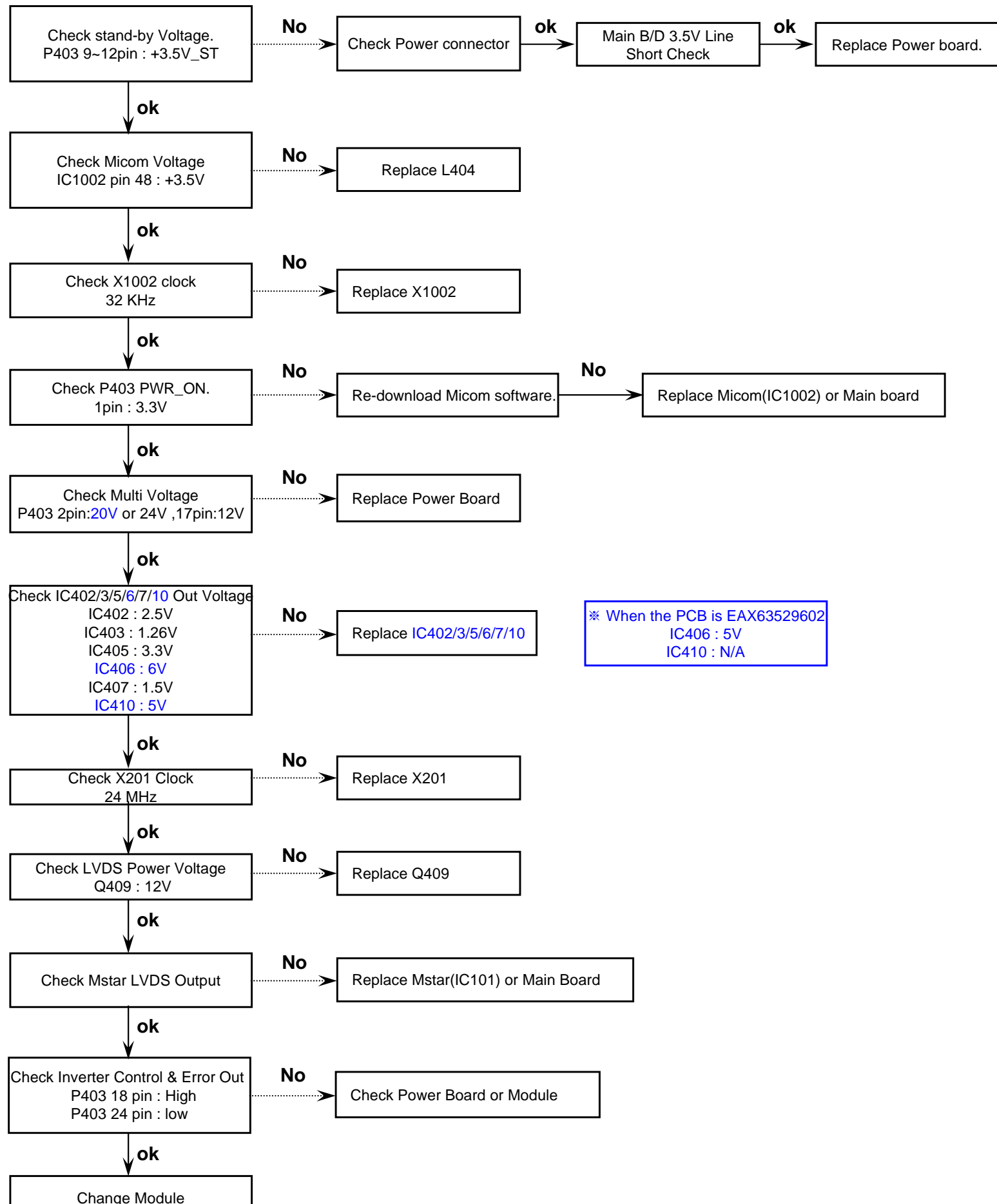

Trouble shooting guide

2. Digital TV Video

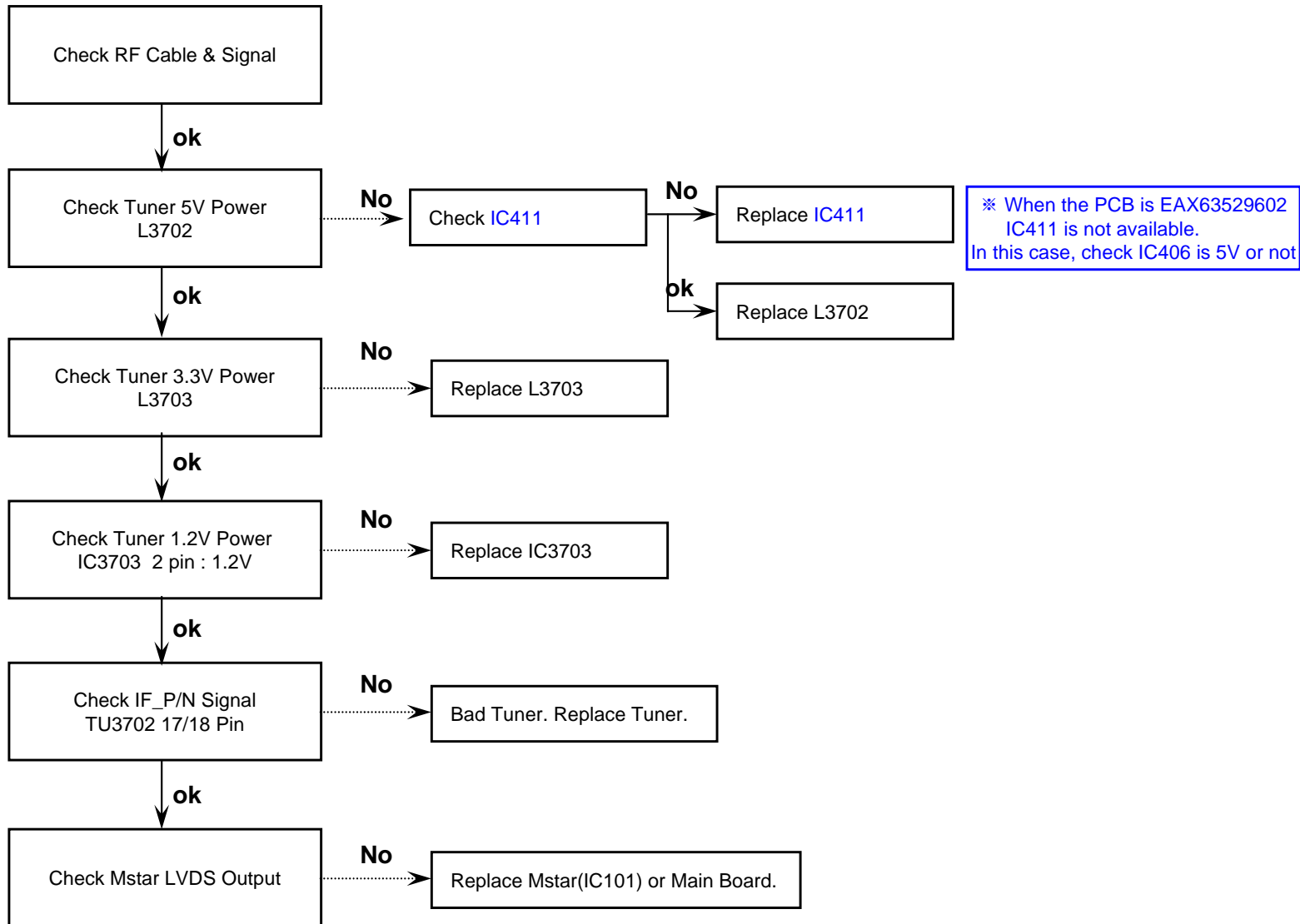

Trouble shooting guide

4. AV Video

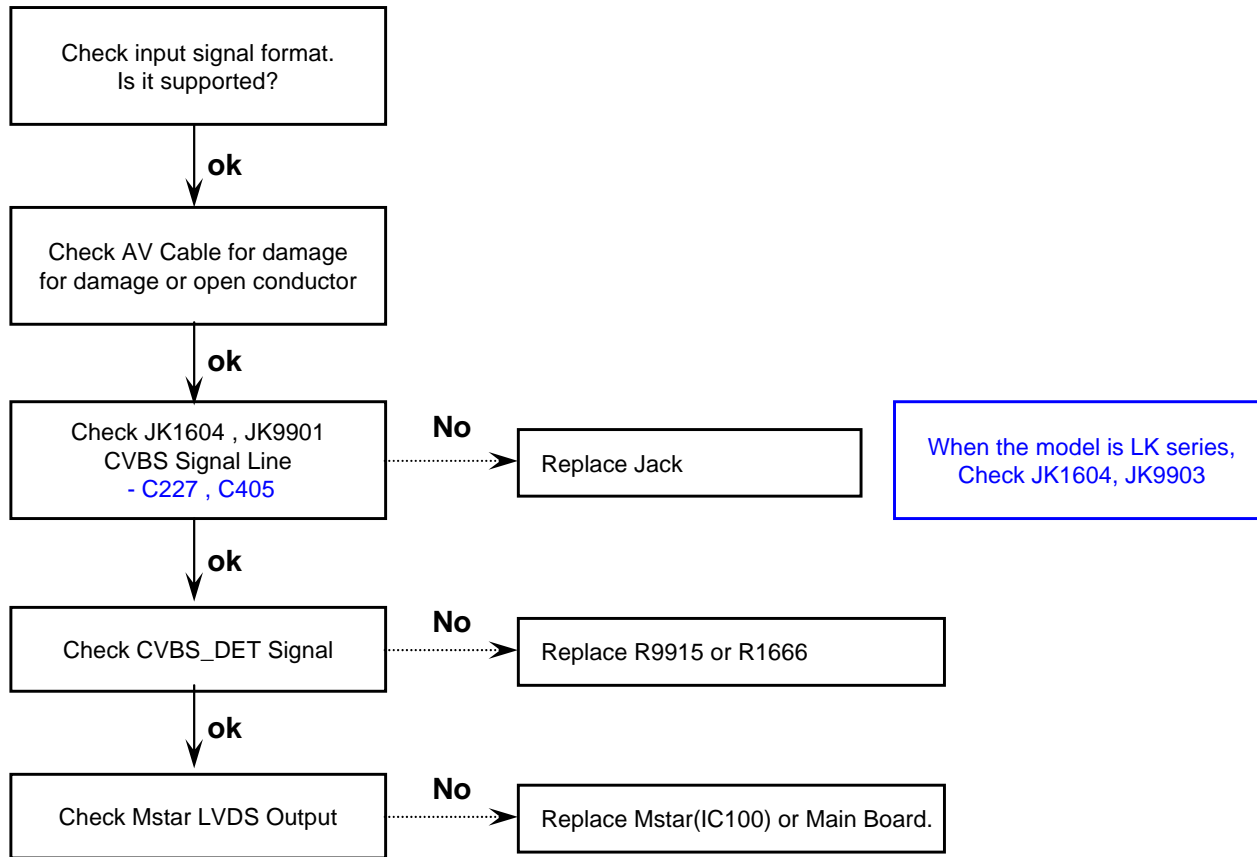

5. Component Video

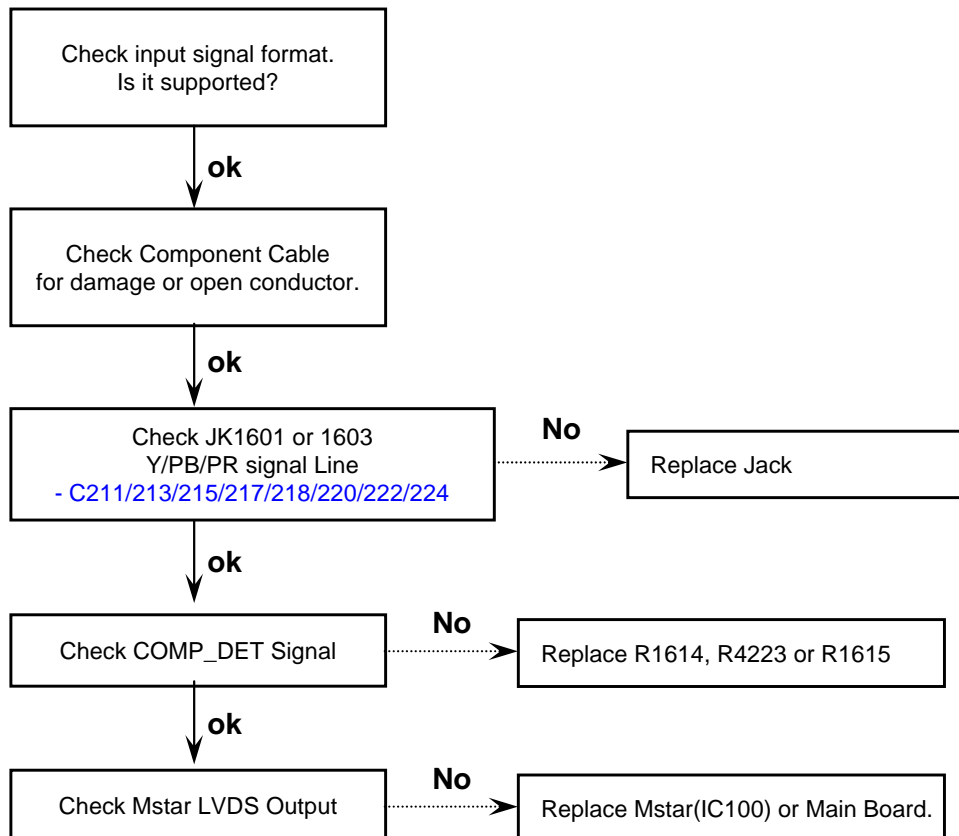

Trouble shooting guide

6. RGB Video

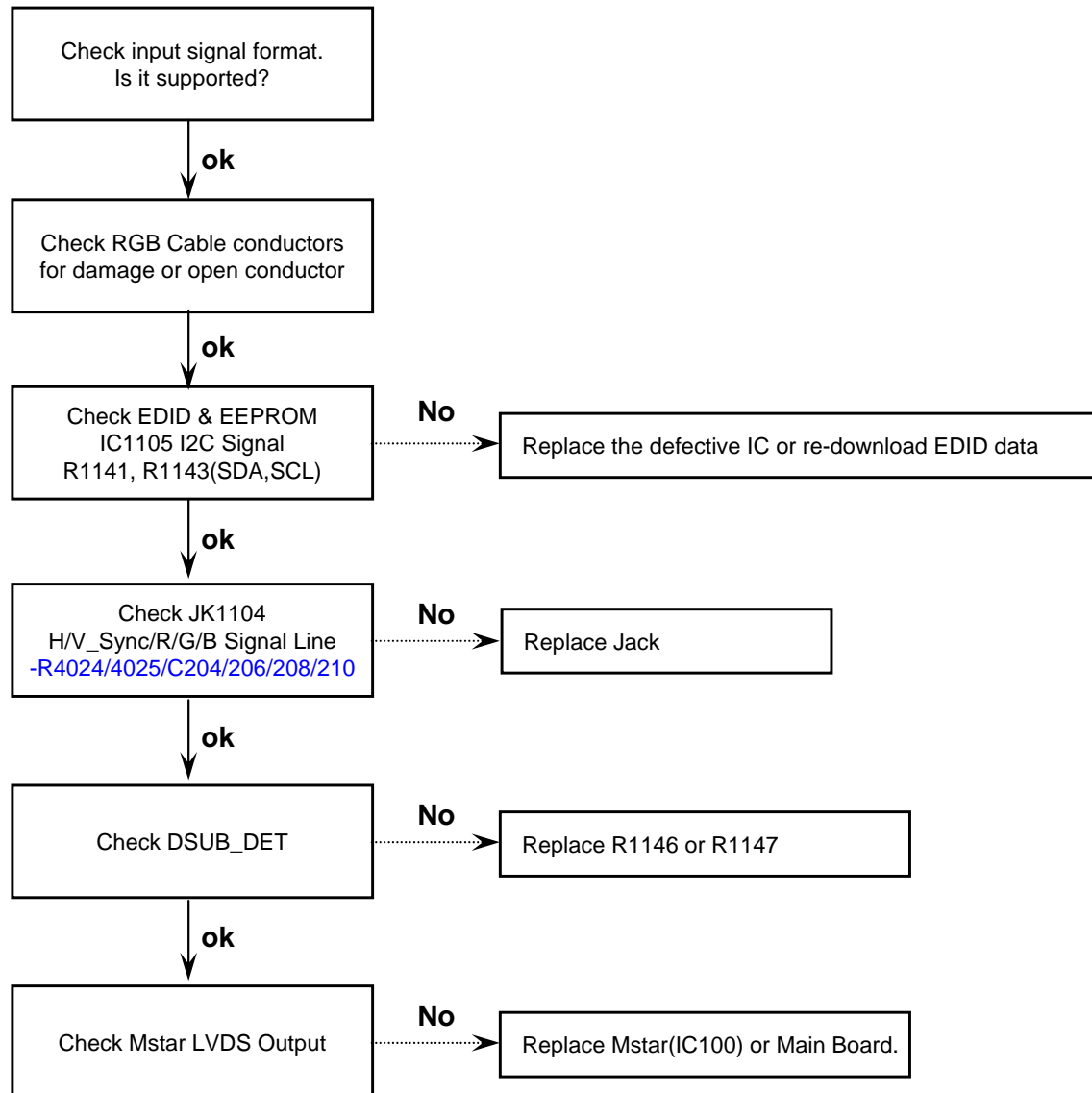

Trouble shooting guide

7. HDMI Video

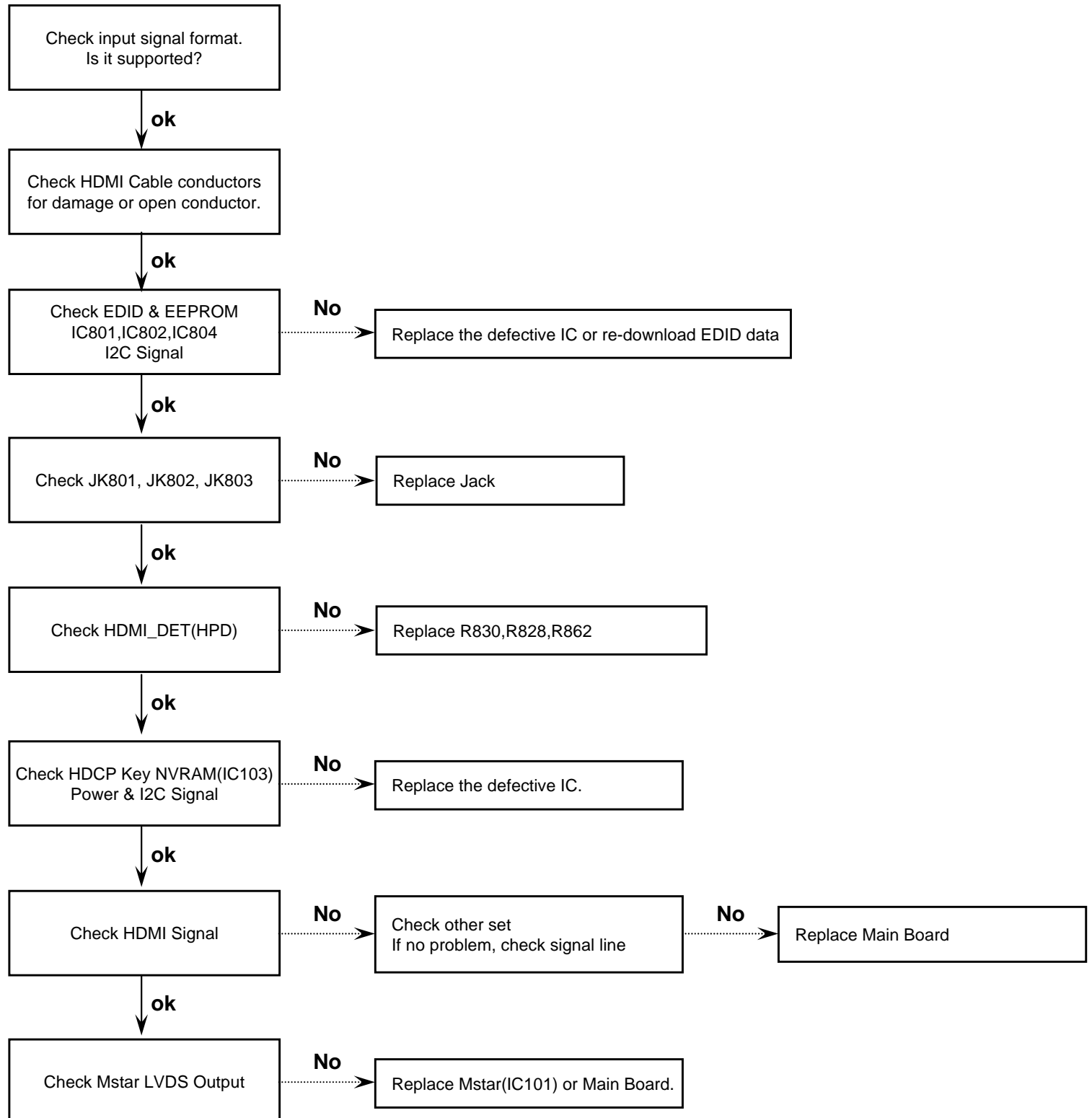

Trouble shooting guide

8. All Source Audio

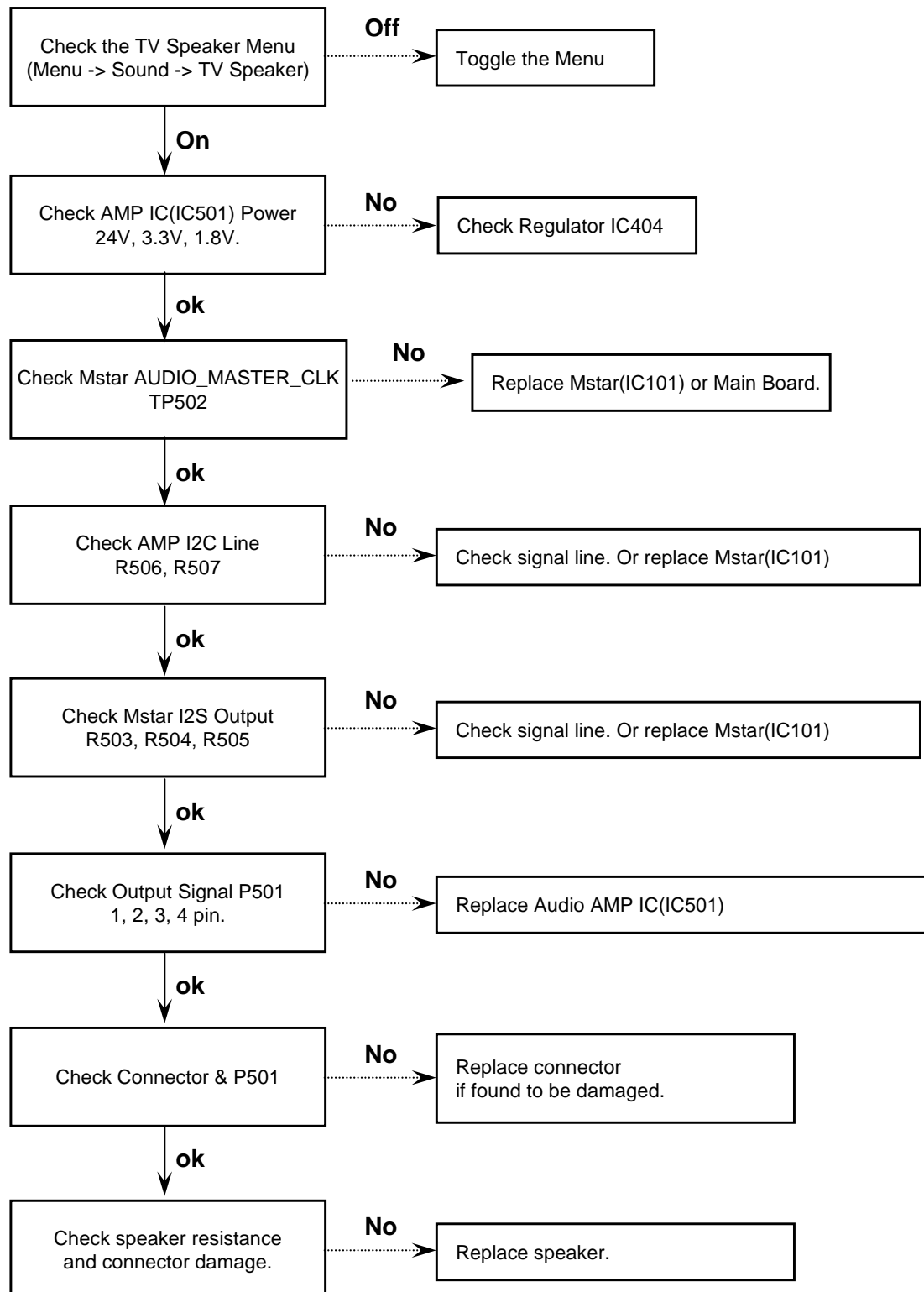

Trouble shooting guide

9. Digital TV Audio

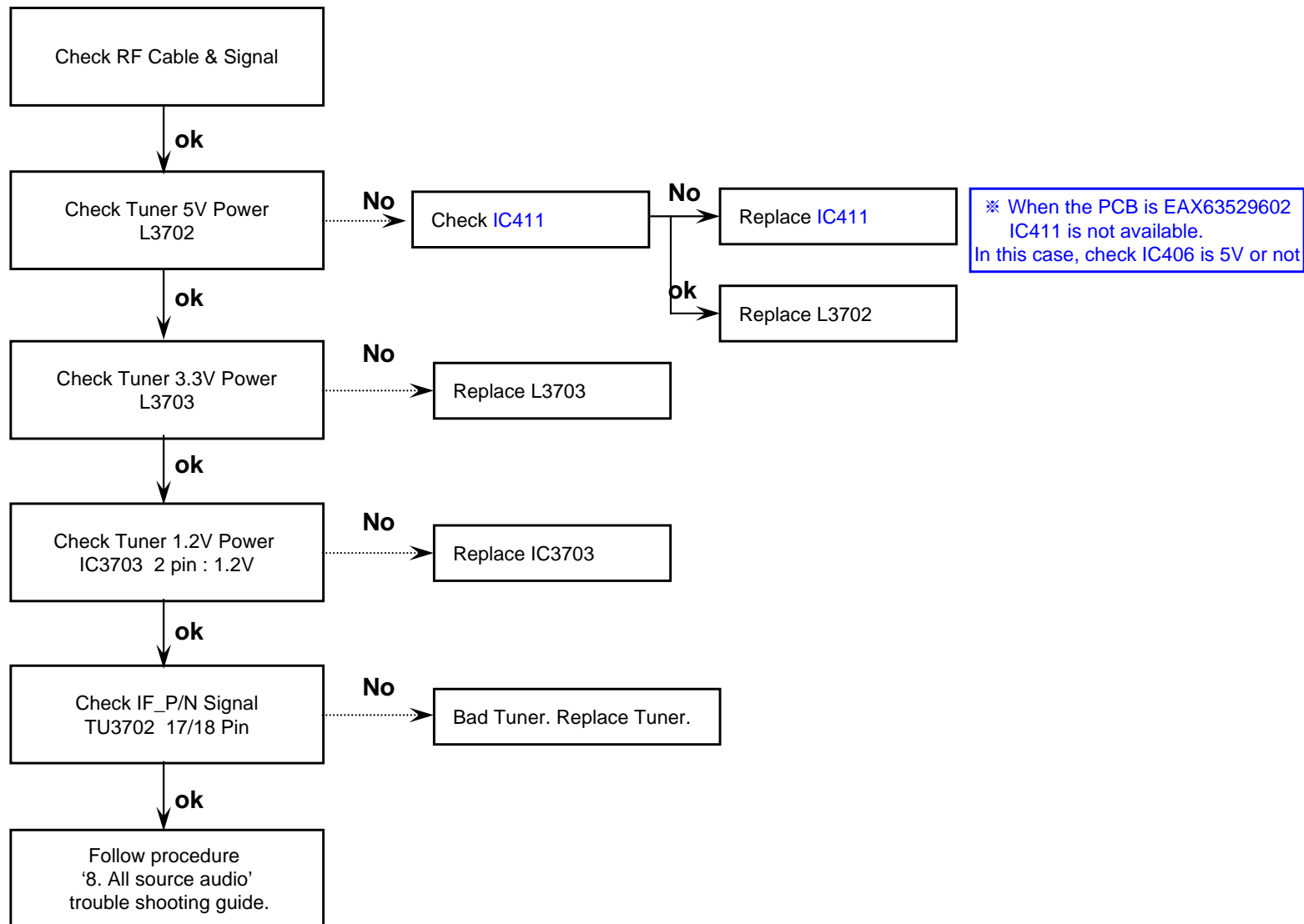

Trouble shooting guide

10. Analog TV Audio

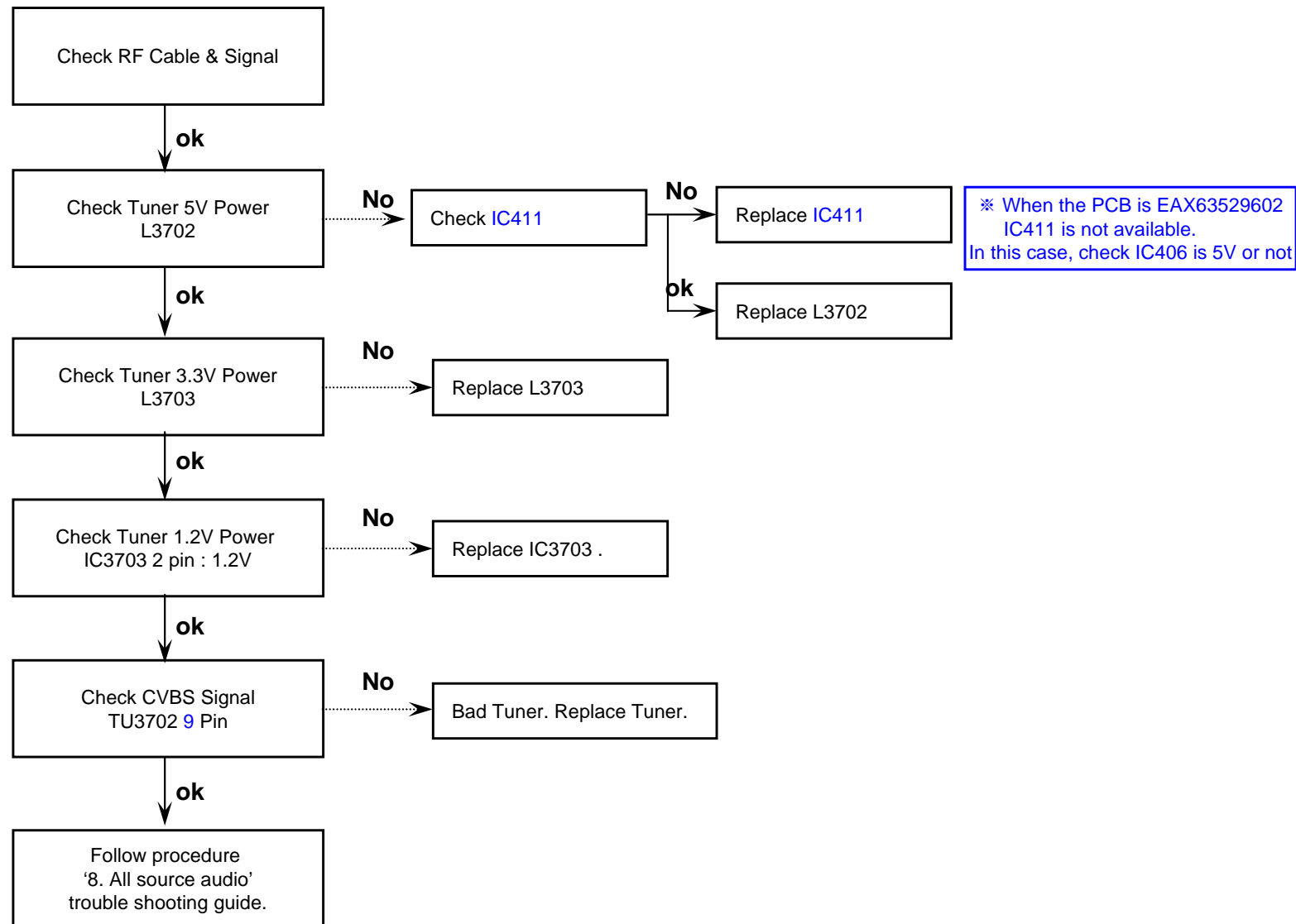

Trouble shooting guide

11. AV Audio

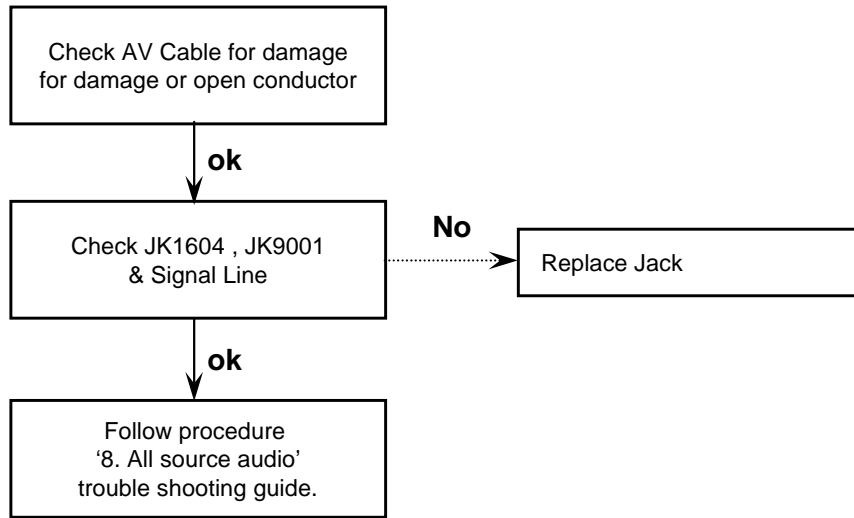

12. Component Audio

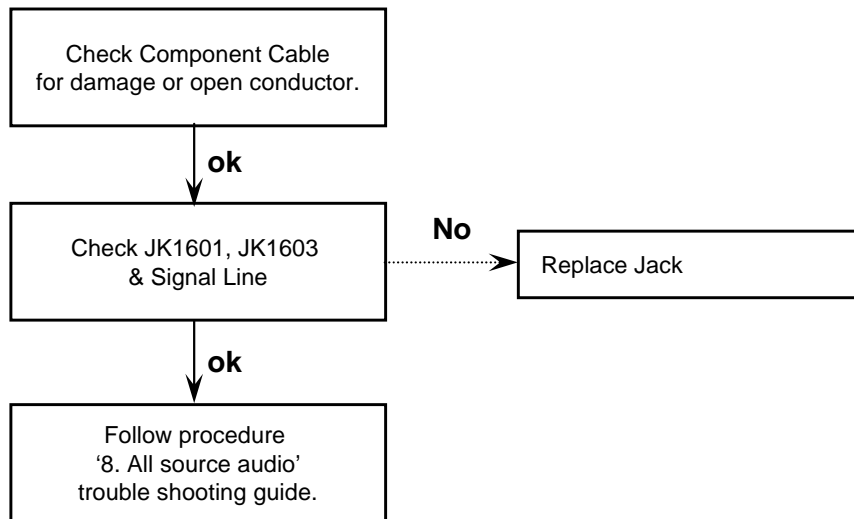

13. RGB Audio

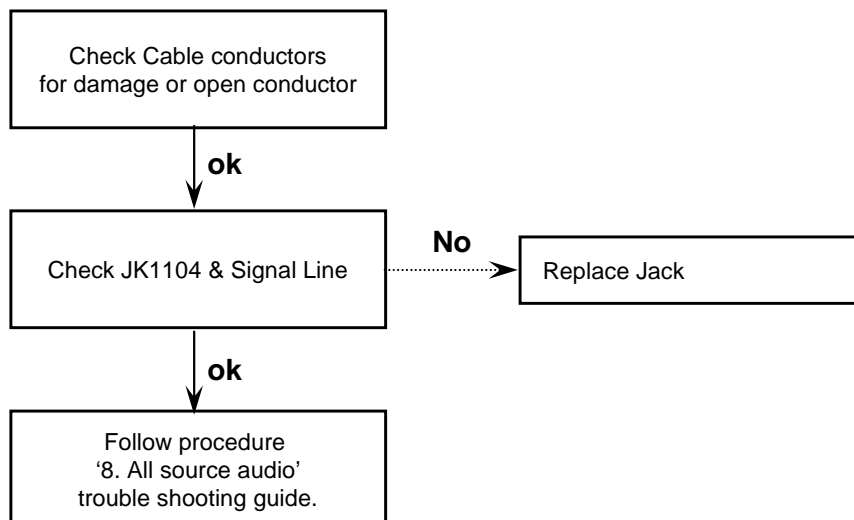

Trouble shooting guide

14. USB : movie, music, picture

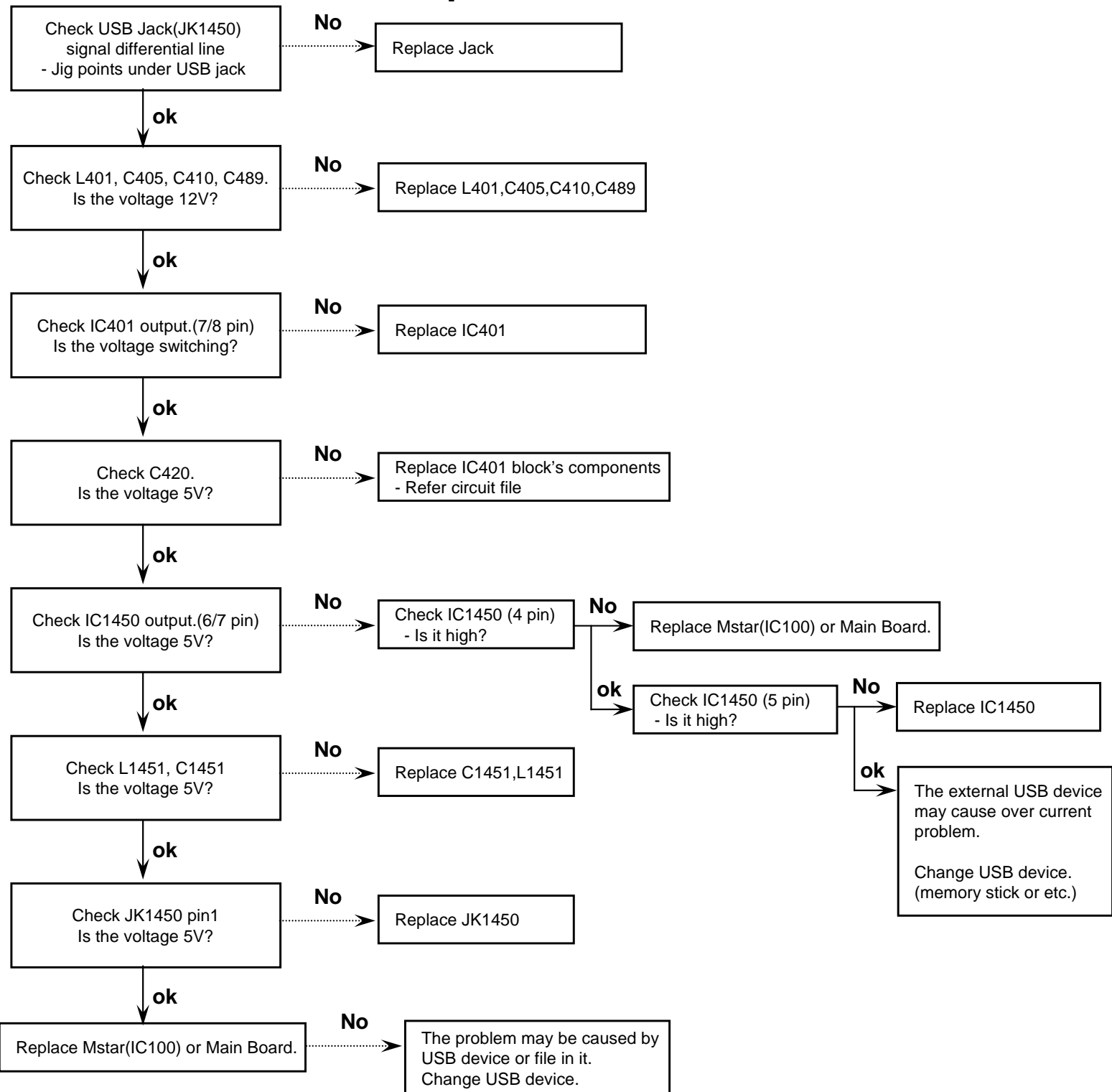

S7R / S7MR Block Diagram – LK models

