



LG

Life's Good

North/Latin America
Europe/Africa
Asia/Oceania

Internal Use Only

<http://aic.lgservice.com>
<http://eic.lgservice.com>
<http://biz.lgservice.com>

LED TV

SERVICE MANUAL

CHASSIS : LA43B

MODEL : 60LB5900 60LB5900-UV

CAUTION

BEFORE SERVICING THE CHASSIS,
READ THE SAFETY PRECAUTIONS IN THIS MANUAL.



CONTENTS

CONTENTS	2
PRODUCT SAFETY	3
SPECIFICATION	4
ADJUSTMENT INSTRUCTION	11
TROUBLE SHOOTING	17
BLOCK DIAGRAM.....	22
EXPLODED VIEW	25
SCHEMATIC CIRCUIT DIAGRAM	

SAFETY PRECAUTIONS

IMPORTANT SAFETY NOTICE

Many electrical and mechanical parts in this chassis have special safety-related characteristics. These parts are identified by  in the Schematic Diagram and Exploded View.

It is essential that these special safety parts should be replaced with the same components as recommended in this manual to prevent Shock, Fire, or other Hazards.

Do not modify the original design without permission of manufacturer.

General Guidance

An **isolation Transformer should always be used** during the servicing of a receiver whose chassis is not isolated from the AC power line. Use a transformer of adequate power rating as this protects the technician from accidents resulting in personal injury from electrical shocks.

It will also protect the receiver and its components from being damaged by accidental shorts of the circuitry that may be inadvertently introduced during the service operation.

If any fuse (or Fusible Resistor) in this TV receiver is blown, replace it with the specified.

When replacing a high wattage resistor (Oxide Metal Film Resistor, over 1 W), keep the resistor 10 mm away from PCB.

Keep wires away from high voltage or high temperature parts.

Before returning the receiver to the customer,

always perform an **AC leakage current check** on the exposed metallic parts of the cabinet, such as antennas, terminals, etc., to be sure the set is safe to operate without damage of electrical shock.

Leakage Current Cold Check(Antenna Cold Check)

With the instrument AC plug removed from AC source, connect an electrical jumper across the two AC plug prongs. Place the AC switch in the on position, connect one lead of ohm-meter to the AC plug prongs tied together and touch other ohm-meter lead in turn to each exposed metallic parts such as antenna terminals, phone jacks, etc.

If the exposed metallic part has a return path to the chassis, the measured resistance should be between 1 M Ω and 5.2 M Ω .

When the exposed metal has no return path to the chassis the reading must be infinite.

An other abnormality exists that must be corrected before the receiver is returned to the customer.

Leakage Current Hot Check (See below Figure)

Plug the AC cord directly into the AC outlet.

Do not use a line Isolation Transformer during this check.

Connect 1.5 K / 10 watt resistor in parallel with a 0.15 μ F capacitor between a known good earth ground (Water Pipe, Conduit, etc.) and the exposed metallic parts.

Measure the AC voltage across the resistor using AC voltmeter with 1000 ohms/volt or more sensitivity.

Reverse plug the AC cord into the AC outlet and repeat AC voltage measurements for each exposed metallic part. Any voltage measured must not exceed 0.75 volt RMS which corresponds to 0.5 mA.

In case any measurement is out of the limits specified, there is possibility of shock hazard and the set must be checked and repaired before it is returned to the customer.

Leakage Current Hot Check circuit

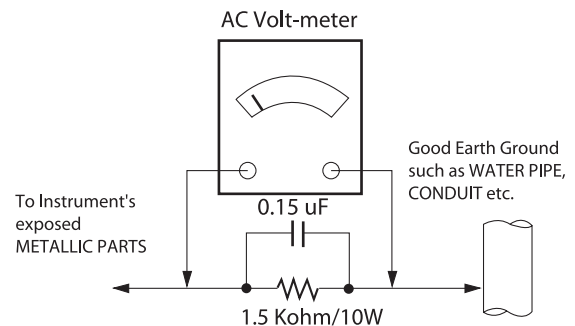

When 25A is impressed between Earth and 2nd Ground for 1 second, Resistance must be less than 0.1 Ω

*Base on Adjustment standard

SERVICING PRECAUTIONS

CAUTION: Before servicing receivers covered by this service manual and its supplements and addenda, read and follow the *SAFETY PRECAUTIONS* on page 3 of this publication.

NOTE: If unforeseen circumstances create conflict between the following servicing precautions and any of the safety precautions on page 3 of this publication, always follow the safety precautions. Remember: Safety First.

General Servicing Precautions

1. Always unplug the receiver AC power cord from the AC power source before;
 - a. Removing or reinstalling any component, circuit board module or any other receiver assembly.
 - b. Disconnecting or reconnecting any receiver electrical plug or other electrical connection.
 - c. Connecting a test substitute in parallel with an electrolytic capacitor in the receiver.

CAUTION: A wrong part substitution or incorrect polarity installation of electrolytic capacitors may result in an explosion hazard.

2. Test high voltage only by measuring it with an appropriate high voltage meter or other voltage measuring device (DVM, FETVOM, etc) equipped with a suitable high voltage probe. Do not test high voltage by "drawing an arc".
3. Do not spray chemicals on or near this receiver or any of its assemblies.
4. Unless specified otherwise in this service manual, clean electrical contacts only by applying the following mixture to the contacts with a pipe cleaner, cotton-tipped stick or comparable non-abrasive applicator: 10 % (by volume) Acetone and 90 % (by volume) isopropyl alcohol (90 % - 99 % strength)
CAUTION: This is a flammable mixture.
Unless specified otherwise in this service manual, lubrication of contacts is not required.
5. Do not defeat any plug/socket B+ voltage interlocks with which receivers covered by this service manual might be equipped.
6. Do not apply AC power to this instrument and/or any of its electrical assemblies unless all solid-state device heat sinks are correctly installed.
7. Always connect the test receiver ground lead to the receiver chassis ground before connecting the test receiver positive lead.
Always remove the test receiver ground lead last.
8. Use with this receiver only the test fixtures specified in this service manual.

CAUTION: Do not connect the test fixture ground strap to any heat sink in this receiver.

Electrostatically Sensitive (ES) Devices

Some semiconductor (solid-state) devices can be damaged easily by static electricity. Such components commonly are called Electrostatically Sensitive (ES) Devices. Examples of typical ES devices are integrated circuits and some field-effect transistors and semiconductor "chip" components. The following techniques should be used to help reduce the incidence of component damage caused by static by static electricity.

1. Immediately before handling any semiconductor component or semiconductor-equipped assembly, drain off any electrostatic charge on your body by touching a known earth ground. Alternatively, obtain and wear a commercially available discharging wrist strap device, which should be removed to prevent potential shock reasons prior to applying power to the unit under test.

2. After removing an electrical assembly equipped with ES devices, place the assembly on a conductive surface such as aluminum foil, to prevent electrostatic charge buildup or exposure of the assembly.
3. Use only a grounded-tip soldering iron to solder or unsolder ES devices.
4. Use only an anti-static type solder removal device. Some solder removal devices not classified as "anti-static" can generate electrical charges sufficient to damage ES devices.
5. Do not use freon-propelled chemicals. These can generate electrical charges sufficient to damage ES devices.
6. Do not remove a replacement ES device from its protective package until immediately before you are ready to install it. (Most replacement ES devices are packaged with leads electrically shorted together by conductive foam, aluminum foil or comparable conductive material).
7. Immediately before removing the protective material from the leads of a replacement ES device, touch the protective material to the chassis or circuit assembly into which the device will be installed.
CAUTION: Be sure no power is applied to the chassis or circuit, and observe all other safety precautions.
8. Minimize bodily motions when handling unpackaged replacement ES devices. (Otherwise harmless motion such as the brushing together of your clothes fabric or the lifting of your foot from a carpeted floor can generate static electricity sufficient to damage an ES device.)

General Soldering Guidelines

1. Use a grounded-tip, low-wattage soldering iron and appropriate tip size and shape that will maintain tip temperature within the range or 500 °F to 600 °F.
2. Use an appropriate gauge of RMA resin-core solder composed of 60 parts tin/40 parts lead.
3. Keep the soldering iron tip clean and well tinned.
4. Thoroughly clean the surfaces to be soldered. Use a mall wire-bristle (0.5 inch, or 1.25 cm) brush with a metal handle.
Do not use freon-propelled spray-on cleaners.
5. Use the following unsoldering technique
 - a. Allow the soldering iron tip to reach normal temperature. (500 °F to 600 °F)
 - b. Heat the component lead until the solder melts.
 - c. Quickly draw the melted solder with an anti-static, suction-type solder removal device or with solder braid.
CAUTION: Work quickly to avoid overheating the circuit board printed foil.
6. Use the following soldering technique.
 - a. Allow the soldering iron tip to reach a normal temperature (500 °F to 600 °F)
 - b. First, hold the soldering iron tip and solder the strand against the component lead until the solder melts.
 - c. Quickly move the soldering iron tip to the junction of the component lead and the printed circuit foil, and hold it there only until the solder flows onto and around both the component lead and the foil.
CAUTION: Work quickly to avoid overheating the circuit board printed foil.
 - d. Closely inspect the solder area and remove any excess or splashed solder with a small wire-bristle brush.

IC Remove/Replacement

Some chassis circuit boards have slotted holes (oblong) through which the IC leads are inserted and then bent flat against the circuit foil. When holes are the slotted type, the following technique should be used to remove and replace the IC. When working with boards using the familiar round hole, use the standard technique as outlined in paragraphs 5 and 6 above.

Removal

1. Desolder and straighten each IC lead in one operation by gently prying up on the lead with the soldering iron tip as the solder melts.
2. Draw away the melted solder with an anti-static suction-type solder removal device (or with solder braid) before removing the IC.

Replacement

1. Carefully insert the replacement IC in the circuit board.
2. Carefully bend each IC lead against the circuit foil pad and solder it.
3. Clean the soldered areas with a small wire-bristle brush. (It is not necessary to reapply acrylic coating to the areas).

"Small-Signal" Discrete Transistor Removal/Replacement

1. Remove the defective transistor by clipping its leads as close as possible to the component body.
2. Bend into a "U" shape the end of each of three leads remaining on the circuit board.
3. Bend into a "U" shape the replacement transistor leads.
4. Connect the replacement transistor leads to the corresponding leads extending from the circuit board and crimp the "U" with long nose pliers to insure metal to metal contact then solder each connection.

Power Output, Transistor Device Removal/Replacement

1. Heat and remove all solder from around the transistor leads.
2. Remove the heat sink mounting screw (if so equipped).
3. Carefully remove the transistor from the heat sink of the circuit board.
4. Insert new transistor in the circuit board.
5. Solder each transistor lead, and clip off excess lead.
6. Replace heat sink.

Diode Removal/Replacement

1. Remove defective diode by clipping its leads as close as possible to diode body.
2. Bend the two remaining leads perpendicular y to the circuit board.
3. Observing diode polarity, wrap each lead of the new diode around the corresponding lead on the circuit board.
4. Securely crimp each connection and solder it.
5. Inspect (on the circuit board copper side) the solder joints of the two "original" leads. If they are not shiny, reheat them and if necessary, apply additional solder.

Fuse and Conventional Resistor Removal/Replacement

1. Clip each fuse or resistor lead at top of the circuit board hollow stake.
2. Securely crimp the leads of replacement component around notch at stake top.

3. Solder the connections.

CAUTION: Maintain original spacing between the replaced component and adjacent components and the circuit board to prevent excessive component temperatures.

Circuit Board Foil Repair

Excessive heat applied to the copper foil of any printed circuit board will weaken the adhesive that bonds the foil to the circuit board causing the foil to separate from or "lift-off" the board. The following guidelines and procedures should be followed whenever this condition is encountered.

At IC Connections

To repair a defective copper pattern at IC connections use the following procedure to install a jumper wire on the copper pattern side of the circuit board. (Use this technique only on IC connections).

1. Carefully remove the damaged copper pattern with a sharp knife. (Remove only as much copper as absolutely necessary).
2. Carefully scratch away the solder resist and acrylic coating (if used) from the end of the remaining copper pattern.
3. Bend a small "U" in one end of a small gauge jumper wire and carefully crimp it around the IC pin. Solder the IC connection.
4. Route the jumper wire along the path of the out-away copper pattern and let it overlap the previously scraped end of the good copper pattern. Solder the overlapped area and clip off any excess jumper wire.

At Other Connections

Use the following technique to repair the defective copper pattern at connections other than IC Pins. This technique involves the installation of a jumper wire on the component side of the circuit board.

1. Remove the defective copper pattern with a sharp knife. Remove at least 1/4 inch of copper, to ensure that a hazardous condition will not exist if the jumper wire opens.
2. Trace along the copper pattern from both sides of the pattern break and locate the nearest component that is directly connected to the affected copper pattern.
3. Connect insulated 20-gauge jumper wire from the lead of the nearest component on one side of the pattern break to the lead of the nearest component on the other side. Carefully crimp and solder the connections.

CAUTION: Be sure the insulated jumper wire is dressed so the it does not touch components or sharp edges.

SPECIFICATION

NOTE : Specifications and others are subject to change without notice for improvement.

1. Application range

This spec sheet is applied LCD TV with LA43B/M chassis

2. Test condition

Each part is tested as below without special notice.

- 1) Temperature : $25\text{ }^{\circ}\text{C} \pm 5\text{ }^{\circ}\text{C}$ ($77 \pm 9\text{ }^{\circ}\text{F}$) , CST : $40\text{ }^{\circ}\text{C} \pm 5\text{ }^{\circ}\text{C}$
- 2) Relative Humidity: $65\% \pm 10\%$
- 3) Power Voltage

Market	Input voltage	Frequency	Remark
USA	100~240V	50/60Hz	Standard Voltage of each product is marked by models

- 4) Specification and performance of each parts are followed each drawing and specification by part number in accordance with BOM
- 5) The receiver must be operated for about 20 minutes prior to the adjustment

3. Test method

- 1) Performance: LGE TV test method followed
- 2) Demanded other specification
Safety : UL, CSA, IEC specification
EMC: FCC, ICES, IEC specification

4. General Specification

No	Item	Specification	Result	Remark	
1.	Receiving System	ATSC / NTSC-M / 64 & 256 QAM			
2.	Available Channel	1) VHF : 02~13 2) UHF : 14~69 3) DTV : 02-69 4) CATV : 01~135 5) CADTV : 01~135			
3.	Input Voltage	AC 100 ~ 240V 50/60Hz		Mark : 110V, 60Hz (N.America)	
4.	Market	NORTH AMERICA			
5.	Screen Size	42/49 inch Wide (1920 × 1080)	FHD + 60Hz	All models without HD models	
		60 Inch Wide (1920X1080)	FHD + M120Hz		
		32 inch Wide (1366 × 768)	HD + 60Hz		
6.	Aspect Ratio	16:9			
7.	Tuning System	FS			
8.	Module	POLA	HC600DUF-VHHS1 HC600DUF-VHHS2	HS (Sharp Panel)	60LB6000-Ux 60LB5900-Ux
			LC550DUE-FGA3 LC550DUE-FGA4	LGD	55LB6000-Ux 55LB5900-Ux
			T550HVF04.1 T550HVF04.2	AUO	55LB6000-Ux.xxxJxxx 55LB5900-Ux.xxxJxxx
			HC550DUN-VSHS1 HC550DUN-VSHS2	HS (CSOT Panel)	55LB6000-Ux.xxxCxxx 55LB5900-Ux.xxxCxxx
			LC500DUE-FGA3 LC500DUE-FGA4	LGD	50LB6000-Ux.xxxWxxx 50LB5900-Ux.xxxWxxx
			NC500DUN-VXBP1 NC500DUN-VXBP2	INX	50LB6000-Ux.xxxJxxx 50LB5900-Ux.xxxJxxx
			LC470DUE-FGA3 LC470DUE-FGA4	LGD	47LB6000-Ux 47LB5900-Ux
			LC420DUE-FGP2	LGD	42LB6200-Ux
9.	Operating Environment	1) Temp : 0 ~ 40 deg 2) Humidity : ~ 80 %			
10.	Storage Environment	1) Temp : -20 ~ 60 deg 2) Humidity : ~ 85 %			

5. Supported video resolutions

5.1. Component input(Y, CB/PB, CR/PR)

No	Resolution	H-freq(kHz)	V-freq.(Hz)	Pixel clock(MHz)	Proposed
1	720*480	15.73	60.00	13.5135	SDTV ,DVD 480I
2	720*480	15.73	59.94	13.50	SDTV ,DVD 480I
3	720*480	31.50	60.00	27.027	SDTV 480P
4	720*480	31.47	59.94	27.00	SDTV 480P
5	1280*720	45.00	60.00	74.25	HDTV 720P
6	1280*720	44.96	59.94	74.176	HDTV 720P
7	1920*1080	33.75	60.00	74.25	HDTV 1080I
8	1920*1080	33.72	59.94	74.176	HDTV 1080I
9	1920*1080	67.50	60.00	148.50	HDTV 1080P
10	1920*1080	67.432	59.94	148.352	HDTV 1080P
11	1920*1080	27.00	24.00	74.25	HDTV 1080P
12	1920*1080	26.97	23.94	74.176	HDTV 1080P
13	1920*1080	33.75	30.00	74.25	HDTV 1080P
14	1920*1080	33.71	29.97	74.176	HDTV 1080P

5.2. HDMI Input (DTV / PC)

No.	Resolution	H-freq(kHz)	V-freq.(kHz)	Pixel clock(MHz)	Proposed	Remarks
DTV						
1	720*480	31.500	60.000	27.027	SDTV 480P	
2	720*480	31.470	59.940	27.000	SDTV 480P	
3	1280*720	45.000	60.000	74.250	HDTV 720P	
4	1280*720	44.960	59.940	74.176	HDTV 720P	
5	1920*1080	33.750	60.000	74.250	HDTV 1080I	
6	1920*1080	33.720	59.940	74.176	HDTV 1080I	
7	1920*1080	67.500	60.000	148.500	HDTV 1080P	
8	1920*1080	67.4320	59.940	148.352	HDTV 1080P	
9	1920*1080	27.000	24.000	74.250	HDTV 1080P	
10	1920*1080	26.970	23.976	74.176	HDTV 1080P	
11	1920*1080	33.750	30.000	74.250	HDTV 1080P	
12	1920*1080	33.710	29.970	74.176	HDTV 1080P	
PC						
1	640*350	31.468	70.09	25.17	EGA	X
2	720*400	31.469	70.08	28.32	DOS	O
3	640*480	31.469	59.94	25.17	VESA(VGA)	O
4	800*600	37.879	60.31	40.00	VESA(SVGA)	O
5	1024*768	48.363	60.00	65.00	VESA(XGA)	O
6	1152*864	54.348	60.053		VESA	O
7	1280*1024	63.981	60.020	108.0	VESA (SXGA)	O Full HD model Only
8	1360*768	47.712	60.015	85.50	VESA (WXGA)	O
9	1920*1080	67.50	60.00	148.5	HDTV 1080P	O Full HD model Only

6. 3D Mode ('LB6200' models)

6.1. RF Input(DTV)

No.	Resolution	H-freq(kHz)	V-freq.(Hz)	Pixel clock(MHz)	Proposed	Remark
1	1920*1080	45.00	60.00	74.25	HDTV 1080I	Side by Side, Top & Bottom
2	1280*720	45.00	60.00	74.25	HDTV 720P	Side by Side, Top & Bottom

6.2. HDMI Input

(a) HDMI Input(1.4a)

- When connect the cable on TV or change the input mode, 3D display on automatically
- Display OSD information => 1920x2205 [1080p 24], 1280x1470 [720p 60]

No.	Resolution	H-freq(kHz)	V-freq.(Hz)	Pixel clock(MHz)	Proposed	3D input proposed mode
1	1280*720	89.9 / 90	59.94/60	148.35/148.50	HDTV 720P	Frame packing (720 60p)
2	1280*720	45	60	74.25	HDTV 720P	Side by Side(half), Top & Bottom
3	1920*1080	53.95 / 54	23.98 / 24	148.35/148.50	HDTV 1080P	Frame packing (1080 24p)
4	1920*1080	67.5	60	148.50	HDTV 1080P	Side by Side(half), Top & bottom
5	1920*1080	33.7	60	74.25	HDTV 1080i	Side by Side(half), Top & Bottom
6	1920*1080	27	24	74.25	HDTV 1080P	Side by Side(half), Top & Bottom
7	1920*1080	33.7	30	74.25	HDTV 1080P	Side by Side(half), Top &Bottom

(b) HDMI Input(1.3)

- Connect the HDMI cable & receiving the HDMI signal
- Press "3D" key of remote control & select 3D format below.

No.	Resolution	H-freq(kHz)	V-freq.(Hz)	Pixel clock(MHz)	Proposed	3D input proposed mode
1	1280*720	45.00	60.00	74.25	HDTV 720P	Side by Side, Top & Bottom
2	1920*1080	33.75	60.00	74.25	HDTV 1080I	Side by Side, Top & Bottom
3	1920*1080	27.00	24.00	74.25	HDTV 1080P	Side by Side, Top & Bottom
4	1920*1080	33.75	30.00	74.25	HDTV 1080P	Side by Side, Top & Bottom
5	1920*1080	67.50	60.00	148.5	HDTV 1080P	Side by Side, Top & Bottom, Single Frame Sequential

6.3. USB Input

(a) Movie

No.	Resolution	H-freq(kHz)	V-freq.(Hz)	Pixel clock(MHz)	Proposed	3D input proposed mode
1	1920*1080	33.75	30.00	74.25	HDTV 1080P	Side by Side, Top & Bottom

(b) MPO Picture 3D : when selecting the MPO file, Automatically 3D on

(c) 3D Demo in store mode



No.	Resolution	H-freq(kHz)	V-freq.(Hz)	Pixel clock(MHz)	Proposed	3D input proposed mode
1	1920*1080	33.75	30.00	74.25	HDTV 1080P	Side by Side

6.4. 2D to 3D Mode

6.5. DLNA

No.	Resolution	H-freq(kHz)	V-freq.(Hz)	Pixel clock(MHz)	Proposed	3D input proposed mode
1	1920*1080	33.75	30.00	74.25	HDTV 1080P	Side by Side, Top & Bottom

6.6. Remark: 3D Input mode

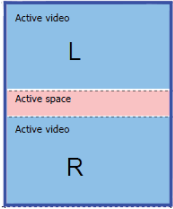
No	2D to 3D	Top & Bottom	Side by Side	Single Frame Sequential	Frame Packing
1					

ADJUSTMENT INSTRUCTION

1. Application

This spec. sheet applies to LA43B/M Chassis applied LED TV all models manufactured in TV factory

2. Specification

- (1) Because this is not a hot chassis, it is not necessary to use an isolation transformer. However, the use of isolation transformer will help protect test instrument.
- (2) Adjustment must be done in the correct order.
- (3) The adjustment must be performed in the circumstance of 25 ± 5 °C of temperature and $65 \pm 10\%$ of relative humidity if there is no specific designation
- (4) The input voltage of the receiver must keep 100~240V, 50/60Hz
- (5) At first Worker must turn on the SET by using Power Only key.
- (6) The receiver must be operated for about 5 minutes prior to the adjustment when module is in the circumstance of over 15 °C
In case of keeping module is in the circumstance of 0°C, it should be placed in the circumstance of above 15°C for 2 hours
In case of keeping module is in the circumstance of below -20°C, it should be placed in the circumstance of above 15°C for 3 hours.

※ Caution

When still image is displayed for a period of 20 minutes or longer (especially where W/B scale is strong. Digital pattern 13ch and/or Cross hatch pattern 09ch), there can some afterimage in the black level area

3. Adjustment items

3.1. Main PCBA Adjustments

- (1) ADC adjustment: Component 480i, 1080p / RGB-PC 1080p
- (2) EDID download: HDMI and RGB-PC

- Above adjustment items can be also performed in Final Assembly if needed. Adjustment items in both PCBA and final assembly tags can be checked by using the INSTART Menu(1.ADJUST CHECK)
Component 1080p and RGB-PC Adjust will be calculated by 480i adjust value.

3.2. Final assembly adjustment

- (1) White Balance adjustment
- (2) RS-232C functionality check
- (3) Factory Option setting per destination
- (4) Shipment mode setting (In-Stop)
- (5) GND and HI-POT test

3.3. Appendix

- (1) Shipment conditions
- (2) Tool option menu
- (3) USB Download (S/W Update, Option and Service only)
- (4) Preset CH Information

4. MAIN PCBA Adjustments

4.1. ADC Calibration

4.1.1. Overview

- ADC adjustment is needed to find the optimum black level and gain in Analog-to-Digital device and to compensate RGB deviation

4.1.2. Equipment & Condition

- (1) Protocol: RS-232C
- (2) Inner Pattern
 - Resolution : 1080p(Comp) / 1024*768(RGB)
 - Pattern : Horizontal 100% Color Bar Pattern
 - Pattern level : 0.7 ± 0.1 Vp-p

4.1.3. Adjustment

4.1.3.1. Adjustment method

- Connect to Jig by using RS-232(USB), adjust Component

※ Manual adj (If needed in Final Assembly)

- Required equipment : Adjustment R/C

- Enter Service Mode by pushing "ADJ" key,

- Start 'OTP' ADC Type by pushing '▶' key at [7. ADC Calibration]

※ In L13 case, Adjust ADC(OTP) is automatically 'OK'

4.1.3.2. Adj. protocol (only Internal patten)

Protocol	CMD 1	CMD 2	Data 1	Data 2	Remark
Enter adj mode	a	a	00	00	When transfer the 'Mode In', Carry the command.
Start ADC adj	a	d	00	10	Automatically adjustment (Use internal pattern)

4.2. EDID Download

4.2.1. Overview

- It is a VESA regulation. A PC or a MNT will display an optimal resolution through information sharing without any necessity of user input. It is a realization of "Plug and Play".

4.2.2. Equipment

- Since embedded EDID data is used, EDID download JIG, HDMI cable and D-sub cable are not need.
- Adjust by using remote controller

4.2.3. Download method

- 1) Press Adj. key on the Adj. R/C,
- 2) Select EDID D/L menu.
- 3) By pressing Enter key, EDID download will begin
- 4) If Download is successful, OK is display, but If Download is failure, NG is displayed.
- 5) If Download is failure, Re-try downloads.

※ Caution) When EDID Download, must remove RGB/HDMI Cable.

4.2.4. EDID DATA

■ L14 EDID - PCM 8. 2D / 8bit / FHD

EDID Block 0, Bytes 0-127 [00H-7FH]

	00	01	02	03	04	05	06	07	08	09	0A	0B	0C	0D	0E	0F
00	00	FF	FF	FF	FF	FF	FF	00	1E	6D	01	00	01	01	01	01
10	01	18	01	03	80	A0	5A	78	0A	EE	91	A3	54	4C	99	26
20	0F	50	54	A1	08	00	31	40	45	40	61	40	71	40	81	80
30	01	01	01	01	01	01	02	3A	80	18	71	38	2D	40	58	2C
40	45	00	40	84	63	00	00	1E	66	21	50	B0	51	00	1B	30
50	40	70	36	00	40	84	63	00	00	1E	00	00	00	FD	00	3A
60	3E	1E	53	10	00	0A	20	20	20	20	20	20	00	00	00	FC
70	00	4C	47	20	54	56	0A	20	20	20	20	20	20	20	01	E7

EDID Block 1, Bytes 128-255 [80H-FFH]

	00	01	02	03	04	05	06	07	08	09	0A	0B	0C	0D	0E	0F
00	02	03	19	F1	48	90	22	20	05	04	03	02	01	23	09	57
10	07	67	03	0C	00	10	00	80	1E	02	3A	80	18	71	38	2D
20	40	58	2C	04	05	40	84	63	00	00	1E	01	1D	80	18	71
30	1C	16	20	58	2C	25	00	40	84	63	00	00	9E	01	1D	00
40	72	51	D0	1E	20	6E	28	55	00	40	84	63	00	00	1E	8C
50	0A	D0	8A	20	E0	2D	10	10	3E	96	00	40	84	63	00	00
60	18	00	00	00	00	00	00	00	00	00	00	00	00	00	00	00
70	00	00	00	00	00	00	00	00	00	00	00	00	00	00	00	08

■ L14 EDID - PCM 9. 2D / 10bit / FHD

EDID Block 0, Bytes 0-127 [00H-7FH]

	00	01	02	03	04	05	06	07	08	09	0A	0B	0C	0D	0E	0F
00	00	FF	FF	FF	FF	FF	FF	00	1E	6D	01	00	01	01	01	01
10	01	18	01	03	80	A0	5A	78	0A	EE	91	A3	54	4C	99	26
20	0F	50	54	A1	08	00	31	40	45	40	61	40	71	40	81	80
30	01	01	01	01	01	01	02	3A	80	18	71	38	2D	40	58	2C
40	45	00	40	84	63	00	00	1E	66	21	50	B0	51	00	1B	30
50	40	70	36	00	40	84	63	00	00	1E	00	00	00	FD	00	3A
60	3E	1E	53	10	00	0A	20	20	20	20	20	20	00	00	00	FC
70	00	4C	47	20	54	56	0A	20	20	20	20	20	20	20	01	E7

EDID Block 1, Bytes 128-255 [80H-FFH]

	00	01	02	03	04	05	06	07	08	09	0A	0B	0C	0D	0E	0F
00	02	03	19	F1	48	90	22	20	05	04	03	02	01	23	09	57
10	07	67	03	0C	00	10	00	B8	2D	02	3A	80	18	71	38	2D
20	40	58	2C	04	05	40	84	63	00	00	1E	01	1D	80	18	71
30	1C	16	20	58	2C	25	00	40	84	63	00	00	9E	01	1D	00
40	72	51	D0	1E	20	6E	28	55	00	40	84	63	00	00	1E	8C
50	0A	D0	8A	20	E0	2D	10	10	3E	96	00	40	84	63	00	00
60	18	00	00	00	00	00	00	00	00	00	00	00	00	00	00	00
70	00	00	00	00	00	00	00	00	00	00	00	00	00	00	00	C1

■ L14 EDID - PCM 11. 3D / 8bit / FHD

EDID Block 0, Bytes 0-127 [00H-7FH]

	00	01	02	03	04	05	06	07	08	09	0A	0B	0C	0D	0E	0F
00	00	FF	FF	FF	FF	FF	FF	00	1E	6D	01	00	01	01	01	01
10	01	18	01	03	80	A0	5A	78	0A	EE	91	A3	54	4C	99	26
20	0F	50	54	A1	08	00	31	40	45	40	61	40	71	40	81	80
30	01	01	01	01	01	01	02	3A	80	18	71	38	2D	40	58	2C
40	45	00	40	84	63	00	00	1E	66	21	50	B0	51	00	1B	30
50	40	70	36	00	40	84	63	00	00	1E	00	00	00	FD	00	3A
60	3E	1E	53	10	00	0A	20	20	20	20	20	20	00	00	00	FC
70	00	4C	47	20	54	56	0A	20	20	20	20	20	20	20	01	E7

EDID Block 1, Bytes 128-255 [80H-FFH]

	00	01	02	03	04	05	06	07	08	09	0A	0B	0C	0D	0E	0F
00	02	03	2A	F1	48	90	22	20	05	04	03	02	01	23	09	57
10	07	78	03	0C	00	10	00	80	1E	02	3A	80	18	71	38	2D
20	40	10	18	10	28	10	38	10	48	10	02	3A	80	18	71	38
30	2D	40	58	2C	04	05	40	84	63	00	00	1E	01	1D	80	18
40	71	1C	16	20	58	2C	25	00	40	84	63	00	00	9E	01	1D
50	00	72	51	D0	1E	20	6E	28	55	00	40	84	63	00	00	1E
60	00	00	00	00	00	00	00	00	00	00	00	00	00	00	00	00
70	00	00	00	00	00	00	00	00	00	00	00	00	00	00	00	DB

5. Final Assembly Adjustment

5.1. White Balance Adjustment

5.1.1. Overview

5.1.1.1. W/B adj. Objective & How-it-works

- (1) Objective: To reduce each Panel's W/B deviation
- (2) How-it-works: When R/G/B gain in the OSD is at 192, it means the panel is at its Full Dynamic Range.

- Case : Cool Mode

- To adjust the white balance without the saturation, G gain should be adjust at least 172 and change the others (R,B Gain)

- When R or B gain is over 255, G gain can be adjust below 172)

- Case : Medium / Warm Mode

- To adjust the white balance without the saturation, Fix the one of R/G/B gain to 192 (default data) and decrease the others.

- (3) Adj. condition: normal temperature

- Surrounding Temperature: 25±5 °C

- Warm-up time: About 5 Min

- Surrounding Humidity: 20% ~ 80%

- Before White balance adjustment, Keep power on status, don't power off

5.1.1.2. Adj. condition and cautionary items

- (1) Lighting condition in surrounding area surrounding lighting should be lower 10 lux. Try to isolate adj. area into dark surrounding.

- (2) Probe location: Color Analyzer (CA-210) probe should be within 10cm and perpendicular of the module surface (80°~ 100°)

- (3) Aging time

- After Aging Start, Keep the Power ON status during 5 Minutes.

- In case of LCD, Back-light on should be checked using no signal or Full-white pattern.

5.1.2. Equipment

- (1) Color Analyzer: CA-210 (NCG: CH 9 / WCG: CH12 / LED: CH14)
 - (2) Adj. Computer (During auto adj., RS-232C protocol is needed)
 - (3) Adjust Remocon
 - (4) Video Signal Generator MSPG-925F 720p/204-Gray (Model: 217, Pattern: 49)
- Only when internal pattern is not available
 ※ Color Analyzer Matrix should be calibrated using CS-1000

5.1.3. Equipment connection

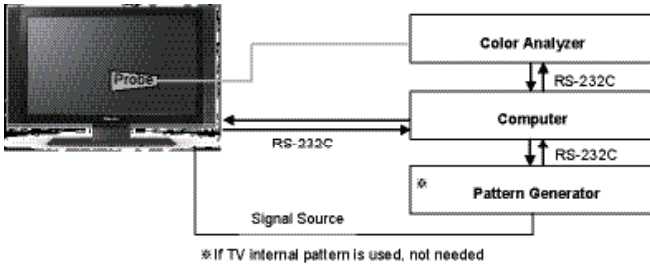

5.1.4. Adjustment Command (Protocol)

- (1) RS-232C Command used during auto-adj.

RS-232C COMMAND			Explanation
CMD	DATA	ID	
Wb	00	00	Begin White Balance adj.
Wb	00	ff	End White Balance adj. (internal pattern disappears)

- (2) Adjustment Map

	Adj. item	Command (lower caseASCII)		Data Range (Hex.)	
		CMD1	CMD2	MIN	MAX
Cool	R Gain	j	g	00	C0
	G Gain	j	h	00	C0
	B Gain	j	i	00	C0
Medium	R Gain	j	a	00	C0
	G Gain	j	b	00	C0
	B Gain	j	c	00	C0
Warm	R Gain	j	d	00	C0
	G Gain	j	e	00	C0
	B Gain	j	f	00	C0

5.1.5. Adjustment method

- 5.1.5.1. Auto WB calibration

- (1) Set TV in ADJ mode using P-ONLY key (or POWER ON key)
 - (2) Place optical probe on the center of the display
- It need to check probe condition of zero calibration before adjustment.
 - (3) Connect RS-232C Cable
 - (4) Select mode in ADJ Program and begin a adjustment.
 - (5) When WB adjustment is completed with OK message, check adjustment status of pre-set mode (Cool, Medium, Warm)
 - (6) Remove probe and RS-232C cable.
- W/B Adj. must begin as start command "wb 00 00" , and finish as end command "wb 00 ff" , and Adj. offset if need

- 5.1.5.2. Manual adjustment

- (1) Set TV in Adj. mode using POWER ON
- (2) Zero Calibrate the probe of Color Analyzer, then place it on the center of LCD module within 10cm of the surface..
- (3) Press ADJ key → EZ adjust using adj. R/C → 8. White-Balance then press the cursor to the right (KEY▶).
(When KEY(▶) is pressed 204 Gray(80IRE) internal pattern will be displayed)
- (4-a) Adjust modes (Cool) : Fix the G gain at least 172 and change the others (R/B Gain).
▪ If R or B gain is over 255, G gain can be adjust below 172.
- (4-b) Adjust two modes (Medium / Warm) : Fix the one of R/G/B gain to 192 (default data) and decrease the others.

※ CASE : Cool mode

First adjust the coordinate far away from the target value(x, y).B

- (1) x, y >target
 - (2) x, y < target
 - (3) x >target , y < target
 - (4) x < target , y >target
- Every 4 case have to fit y value by adjusting B Gain and then fit x value by adjusting R-Gain
 - In this case, increasing/decreasing of B Gain and R Gain can be adjusted.

▶ How to adjust

- (1) Fix G gain at least 172 : Adjust R, B Gain (In Case of Mostly Blue Gain Saturation)
- (2) When R or B Gain > 255, Release Fixed G Gain and Readjust

※ CASE : Medium / Warm mode

First adjust the coordinate far away from the target value(x, y).

- (1) x, y >target
 - i) Decrease the R, G.
- (2) x, y < target
 - i) First decrease the B gain,
 - ii) Decrease the one of the others.
- (3) x >target , y < target
 - i) First decrease B, so make y a little more than the target.
 - ii) Adjust x value by decreasing the R
- (4) x < target , y >target
 - i) First decrease B, so make x a little more than the target.
 - ii) Adjust x value by decreasing the G

5.1.6. Reference (White Balance Adj. coordinate and color temperature)

- Luminance: 204 Gray, 80IRE

** (normal line) LGD Cell (LB5xxx, LB6xxx, LB7xxx, LB8xxx)

** Except Gumi winter season (Mar ~ Dec) & Global

- Standard color coordinate and temperature using CA-210(CH-14) – by aging time

L14	Aging time (Min)	Cool		Medium		Warm	
		X	Y	X	Y	X	Y
		271	270	286	289	313	329
1	0-2	282	289	297	308	324	348
2	3-5	281	287	296	306	323	346
3	6-9	279	284	294	303	321	343
4	10-19	277	280	292	299	319	339
5	20-35	275	277	290	296	317	336
6	36-49	274	274	289	293	316	333
7	50-79	273	272	288	291	315	331
8	80-119	272	271	287	290	314	330
9	Over 120	271	270	286	289	313	329

** (Aging chamber) LGD Cell (LB5xxx, LB6xxx, LB7xxx, LB8xxx)

- Standard color coordinate and temperature using CA-210(CH-14) – by aging time

** (normal line) LGD Cell (LB5xxx, LB6xxx, LB7xxx, LB8xxx)

** Gumi winter season (Jan ~ Feb) & Global, except Cinema Screen models

- Standard color coordinate and temperature using CA-210(CH-14) – by aging time

GP4	Aging time (Min)	Cool		Medium		Warm	
		X	Y	X	Y	X	Y
		271	270	286	289	313	329
1	0-2	286	295	301	314	328	354
2	3-5	284	290	299	309	326	349
3	6-9	282	287	297	306	324	346
4	10-19	279	283	294	302	321	342
5	20-35	276	278	291	297	318	337
6	36-49	274	275	289	294	316	334
7	50-79	273	272	288	291	315	331
8	80-119	272	271	287	290	314	330
9	Over 120	271	270	286	289	313	329

** INX, AUO, Sharp, CSOT Models (Cool Mode Spec : 13000K)

- Standard color coordinate and temperature using CA-210(CH-14) – by aging time

	cool		med		warm	
	x	y	x	y	x	y
spec	271	270	286	289	313	329
target	278	280	293	299	320	339

5.2. Option selection per country

5.2.1. Overview

- (1) Tool option selection is only done for models in Non-USA North America due to rating
- (2) Applied model: LA43B/M Chassis applied to CANADA and MEXICO

5.2.2. Country Group selection

- (1) Press ADJ key on the Adj. R/C, and then select Country Group Menu
- (2) Depending on destination, select US, then on the lower Country option, select US, CA, MX. Selection is done using +, - KEY

5.3. 3D Module inspection

5.3.1. Test equipment

- (1) Pattern Generator MSHG-600 or MSPG-6100 (HDMI 1.4 support)
- (2) Pattern: HDMI mode (model No. 872, pattern No. 83)

5.3.2. Test method

- (1) Start 3D pattern inspection



Fig.1 <model No. 872, pattern No. 83>

- (2) check the 3D pattern with 3D FPR Glasses or L/R Film.

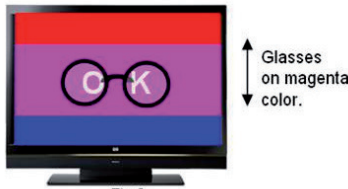

Fig.2
<With Glasses>

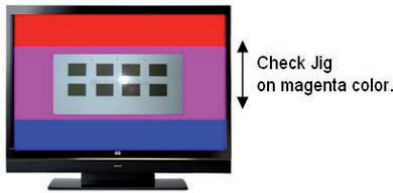

Fig.3
<With Check Jig>

- (3) If 3D Module is correctly worked, The 3D FPR Glasses is change Color.
Left is Red. Right is Blue



Fig.4
< NG in 3D Module >



Fig.5
<OK in 3D module >



Fig.6
< NG in 3D Module >



Fig.7
<OK in 3D module >

6. GND and HI-POT Test

6.1. GND & HI-POT auto-check preparation

- (1) Check the POWER CABLE and SIGNAL CABLE insertion condition

6.2. GND & HI-POT auto-check

- (1) Pallet moves in the station. (POWER CORD / AV CORD is tightly inserted)
- (2) Connect the AV JACK Tester.
- (3) Controller (GWS103-4) on.
- (4) GND Test (Auto)
 - If Test is failed, Buzzer operates.
 - If Test is passed, execute next process (Hi-pot test). (Remove A/V CORD from A/V JACK BOX)
- (5) HI-POT test (Auto)
 - If Test is failed, Buzzer operates.
 - If Test is passed, GOOD Lamp on and move to next process automatically.

6.3. Checkpoint

- (1) Test voltage
 - GND: 1.5KV/min at 100mA
 - SIGNAL: 3KV/min at 100mA
- (2) TEST time: 1 second
- (3) TEST POINT
 - GND Test = POWER CORD GND and SIGNAL CABLE GND.
 - Hi-pot Test = POWER CORD GND and LIVE & NEUTRAL.
- (4) LEAKAGE CURRENT: At 0.5mArms

7. AUDIO output check

7.1. Audio input condition

- (1) RF input: Mono, 1KHz sine wave signal, 100% Modulation
- (2) CVBS, Component: 1KHz sine wave signal (0.4Vrms)
- (3) RGB PC: 1KHz sine wave signal (0.7Vrms)

7.2. Specification

No	Item	Min	Typ	Max	Unit	Remark
1	Audio practical max Output, L/R (Distortion=10% max Output)	9.0 8.5	10.0 8.9	12.0 9.9	W Vrms	(1) Measurement condition - EQ/AVL/Clear Voice: Off (2) Speaker (8Ω Impedance) (3) 60LB6000-UH
2	Audio practical max Output, L/R (Distortion=10% max Output)	9.0 8.5	10.0 8.9	12.0 9.9	W Vrms	(1) Measurement condition - EQ/AVL/Clear Voice: Off (2) Speaker (8Ω Impedance) (3)

8. USB S/W Download (optional, Service only)

- (1) Put the USB Stick to the USB socket
- (2) Automatically detecting update file in USB Stick
 - If your downloaded program version in USB Stick is lower than that of TV set, it didn't work. Otherwise USB data is automatically detected.
- (3) Show the message "Copying files from memory"

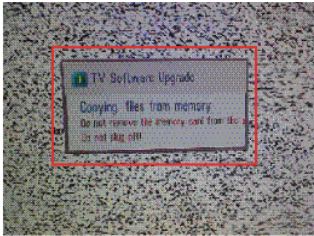

- (4) Updating is starting.

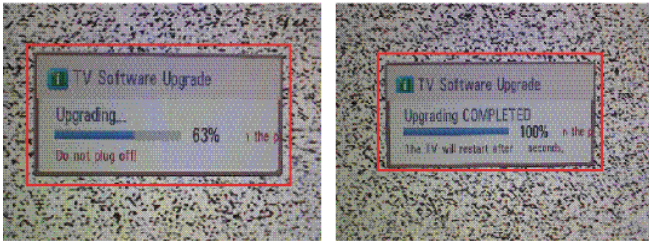

- (5) Updating Completed, The TV will restart automatically
 - (6) If your TV is turned on, check your updated version and Tool option.
- * If downloading version is more high than your TV have, TV can lost all channel data. In this case, you have to channel recover. If all channel data is cleared, you didn't have a DTV/ATV test on production line.
- * After downloading, TOOL OPTION setting is needed again.
- (1) Push "IN-START" key in service remote controller.
 - (2) Select "Tool Option 1" and Push "OK" button.
 - (3) Punch in the number. (Each model has their number.)

TROUBLE SHOOTING

1. Power-up boot check

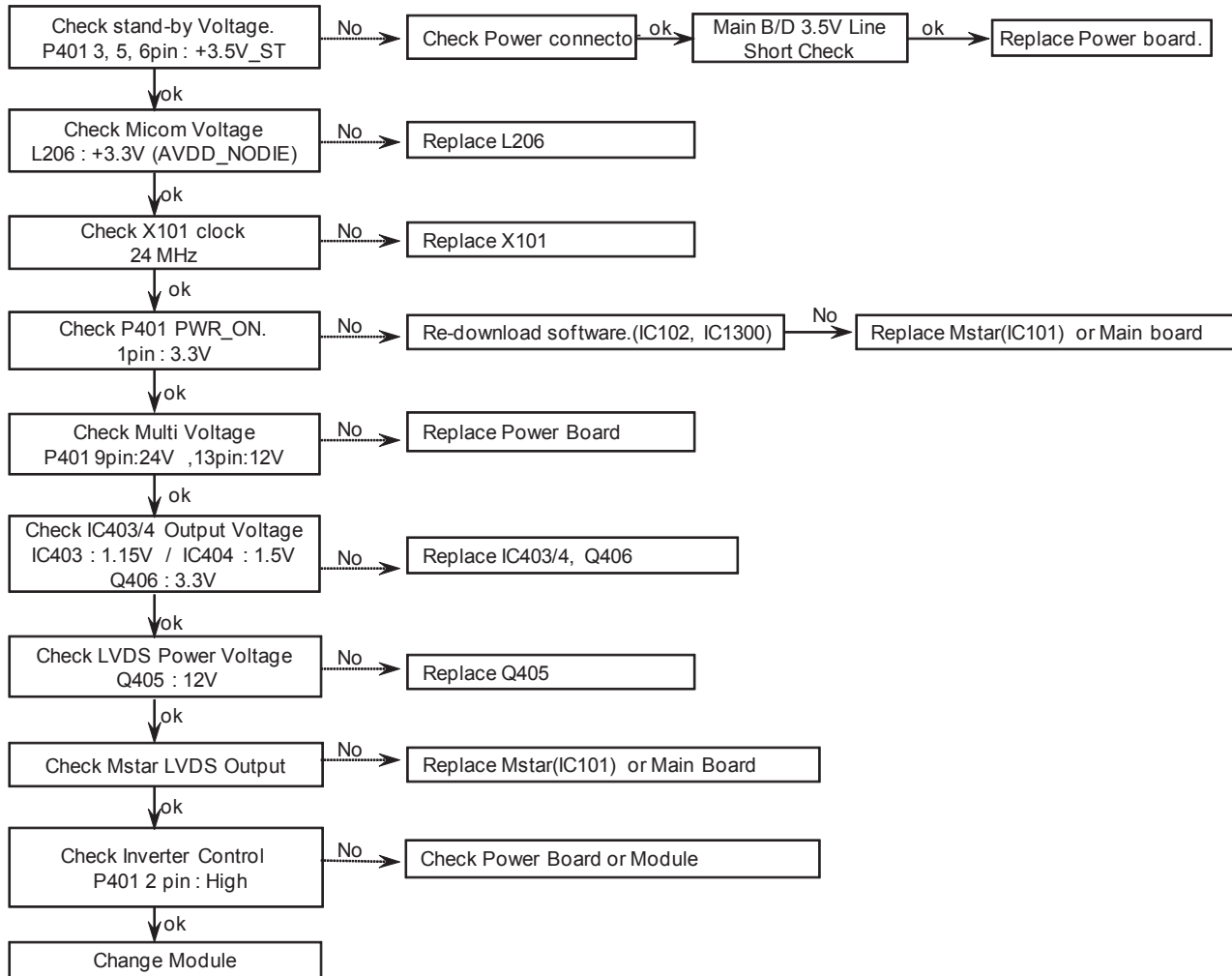

2. Digital / Analog TV Video

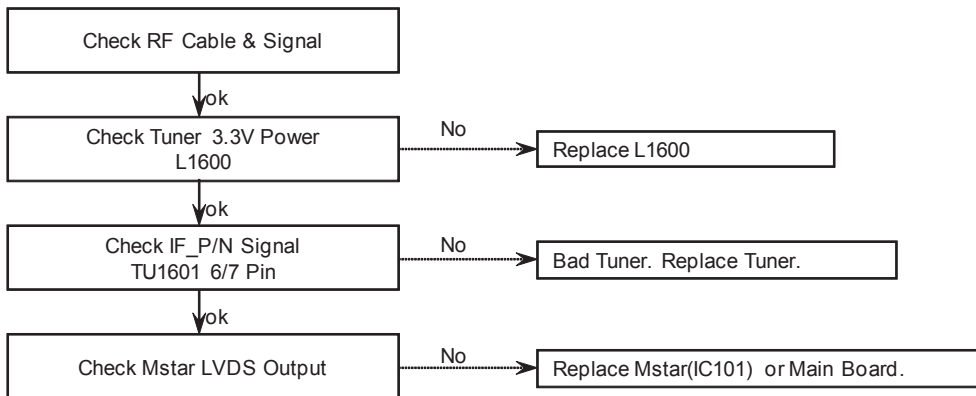

3. AV Video

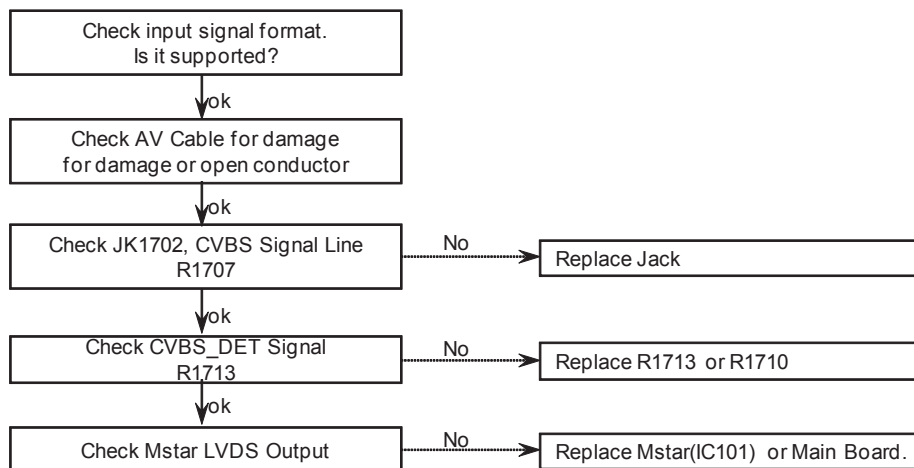

4. Component Video

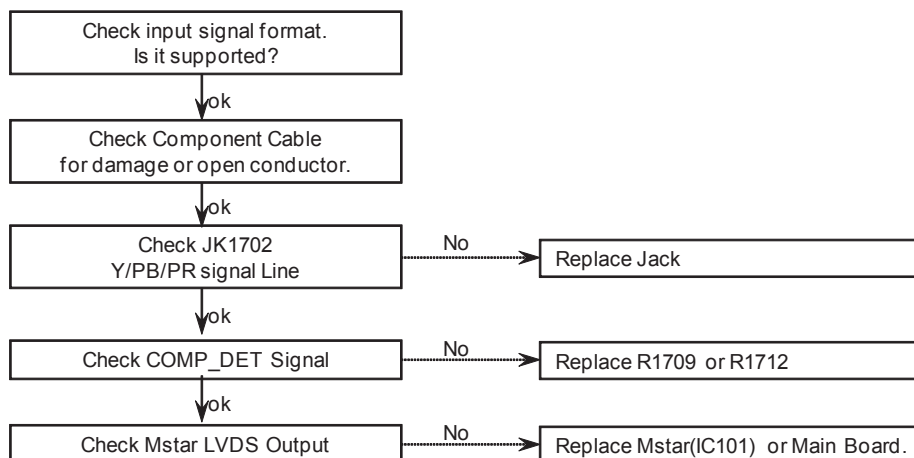

5. HDMI Video

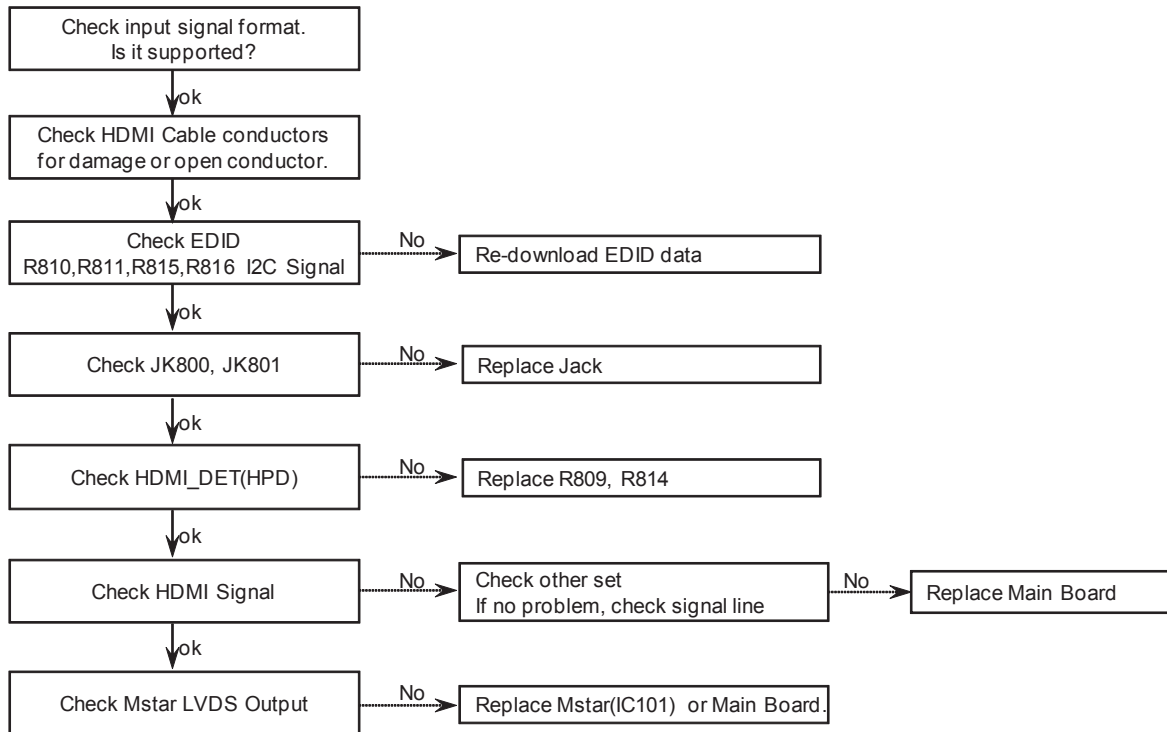

6. All Source Audio

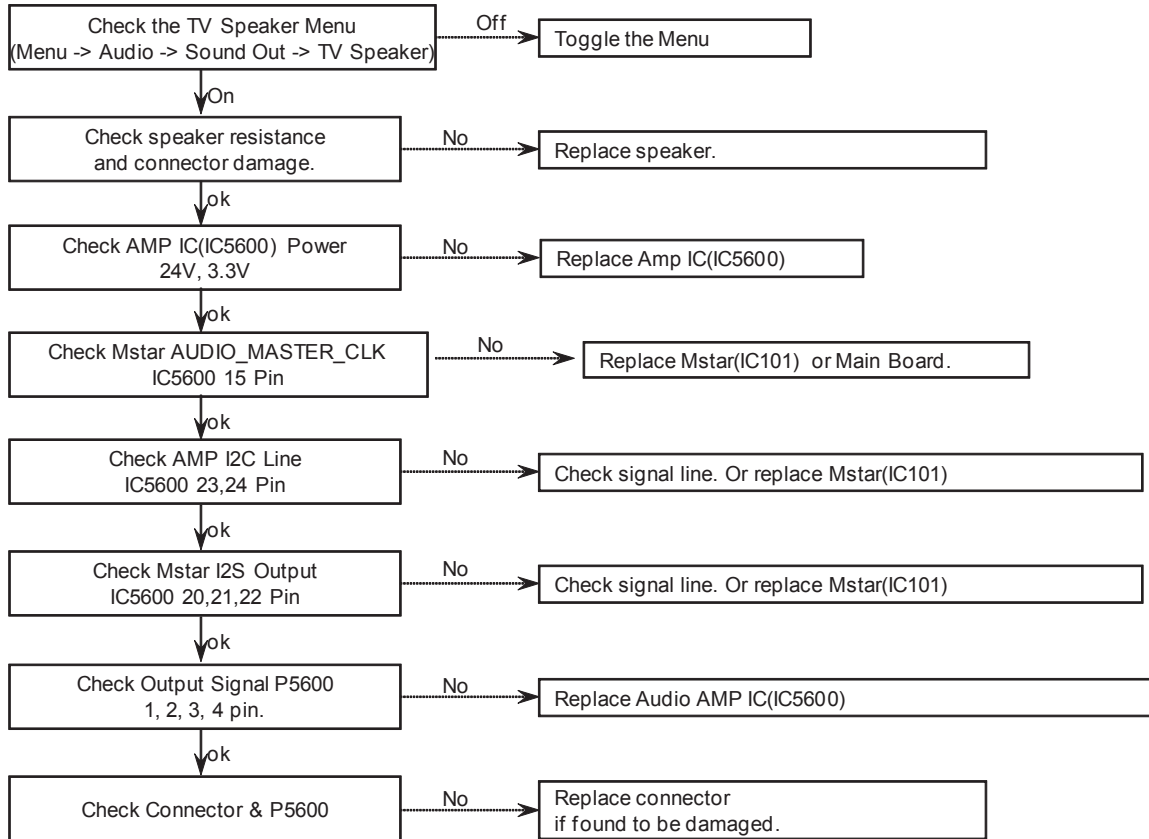

7. Digital / Analog TV Audio

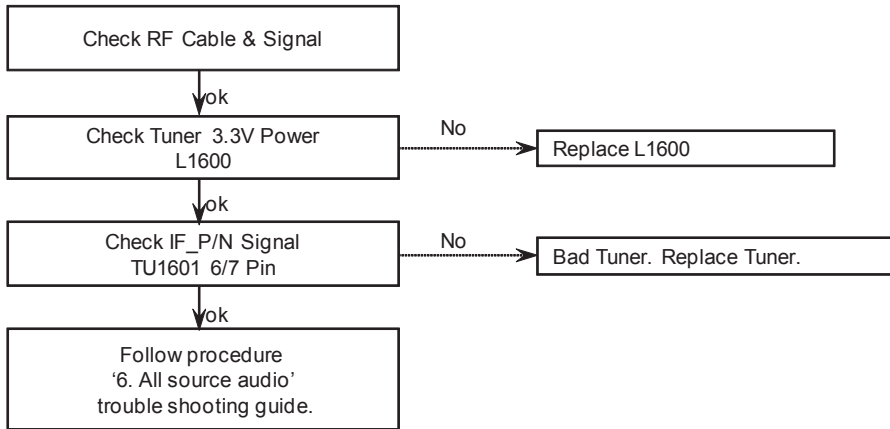

8. AV/Comp Audio

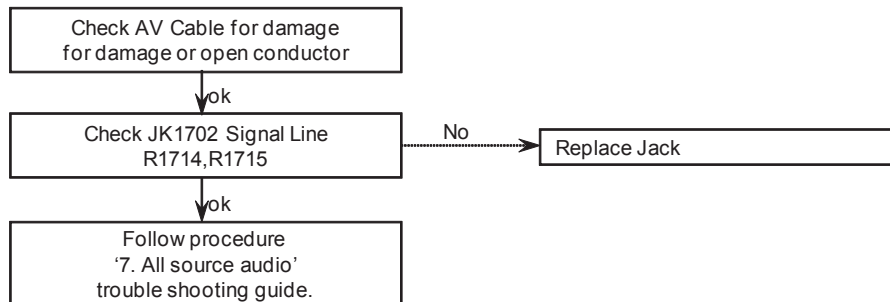

BLOCK DIAGRAM

1. 2D Model

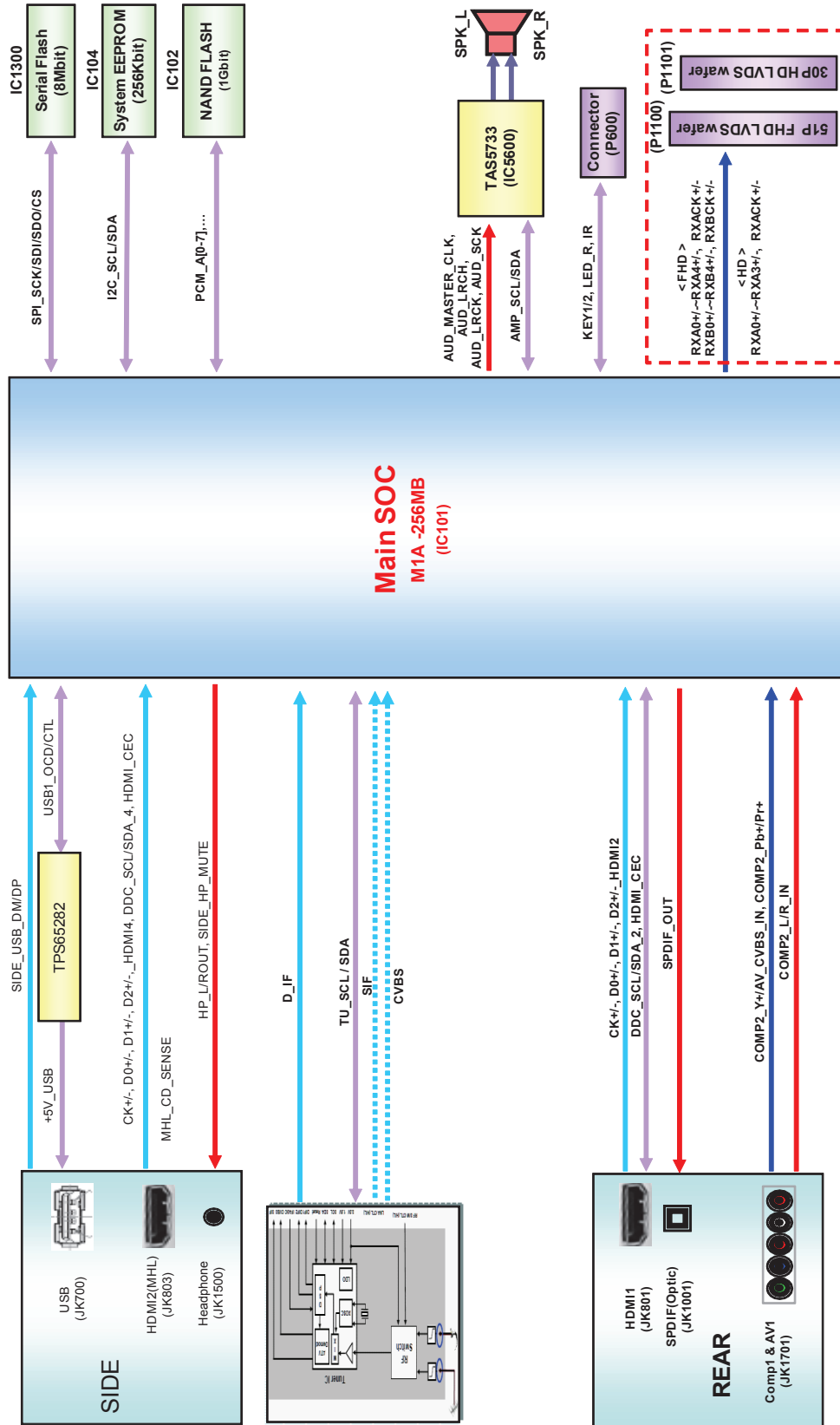

2. 3D Model

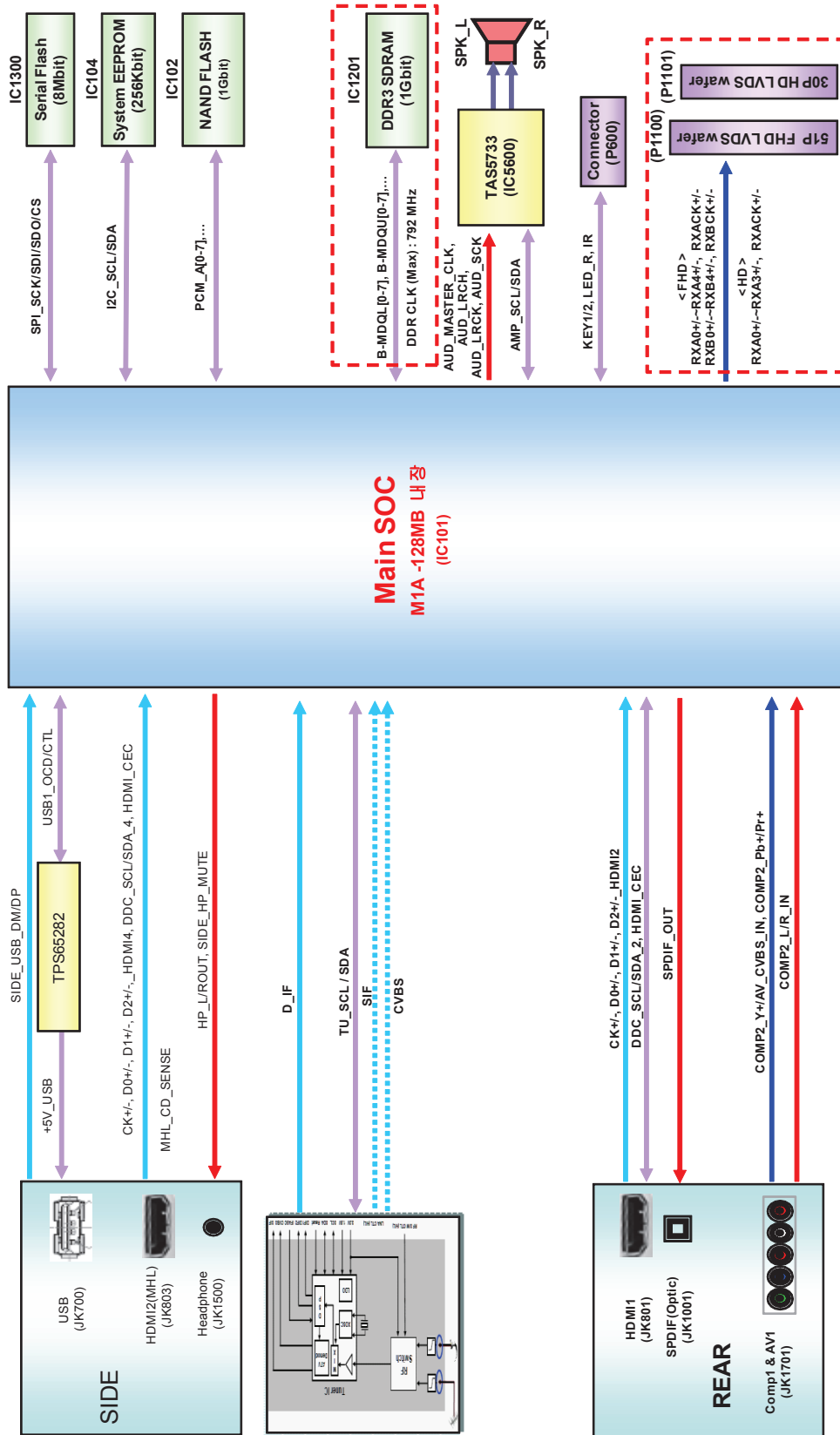

3. I2C Map

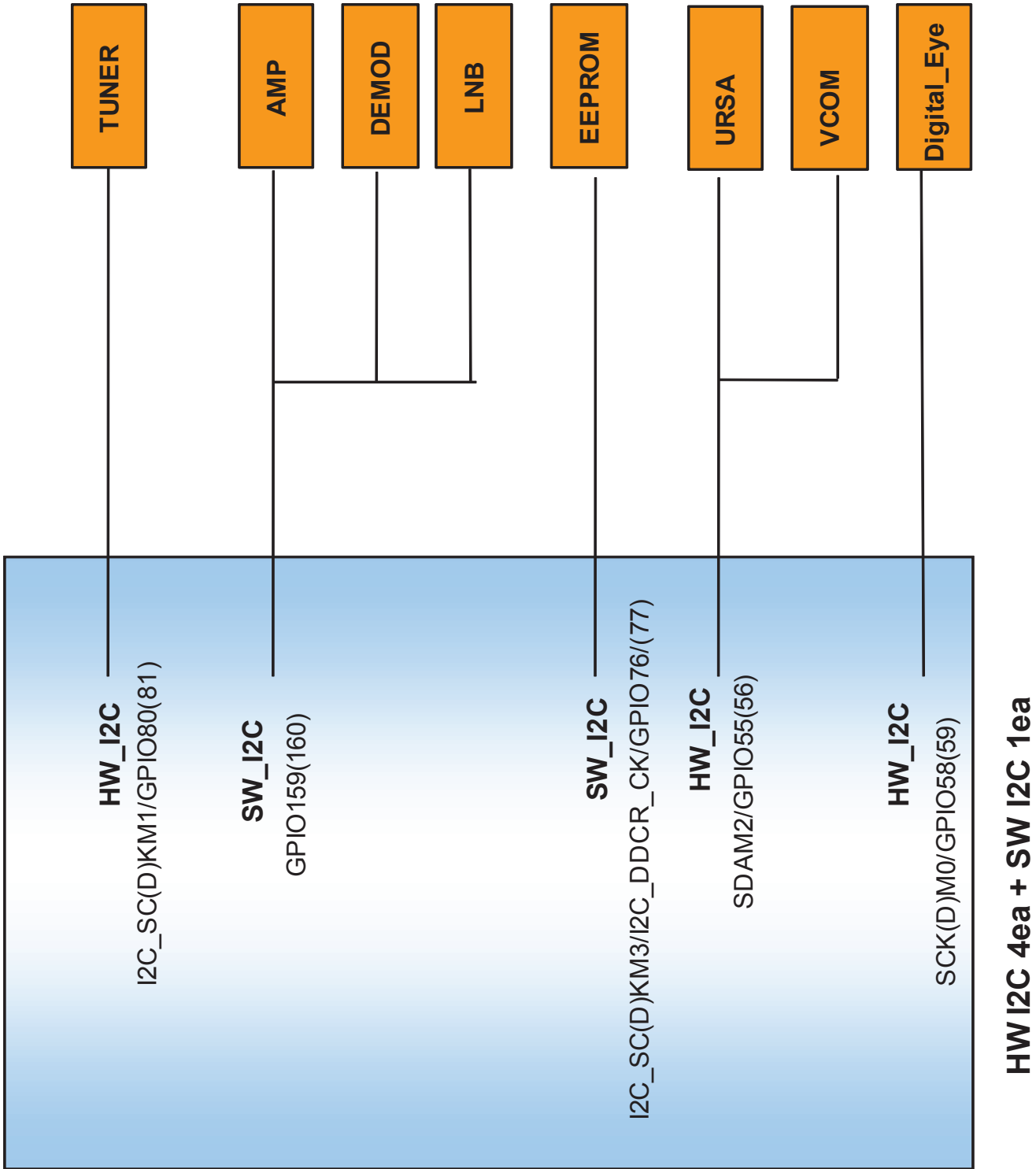

EXPLODED VIEW

IMPORTANT SAFETY NOTICE

Many electrical and mechanical parts in this chassis have special safety-related characteristics. These parts are identified by Δ in the Schematic Diagram and EXPLODED VIEW. It is essential that these special safety parts should be replaced with the same components as recommended in this manual to prevent X-RADIATION, Shock, Fire, or other Hazards. Do not modify the original design without permission of manufacturer.

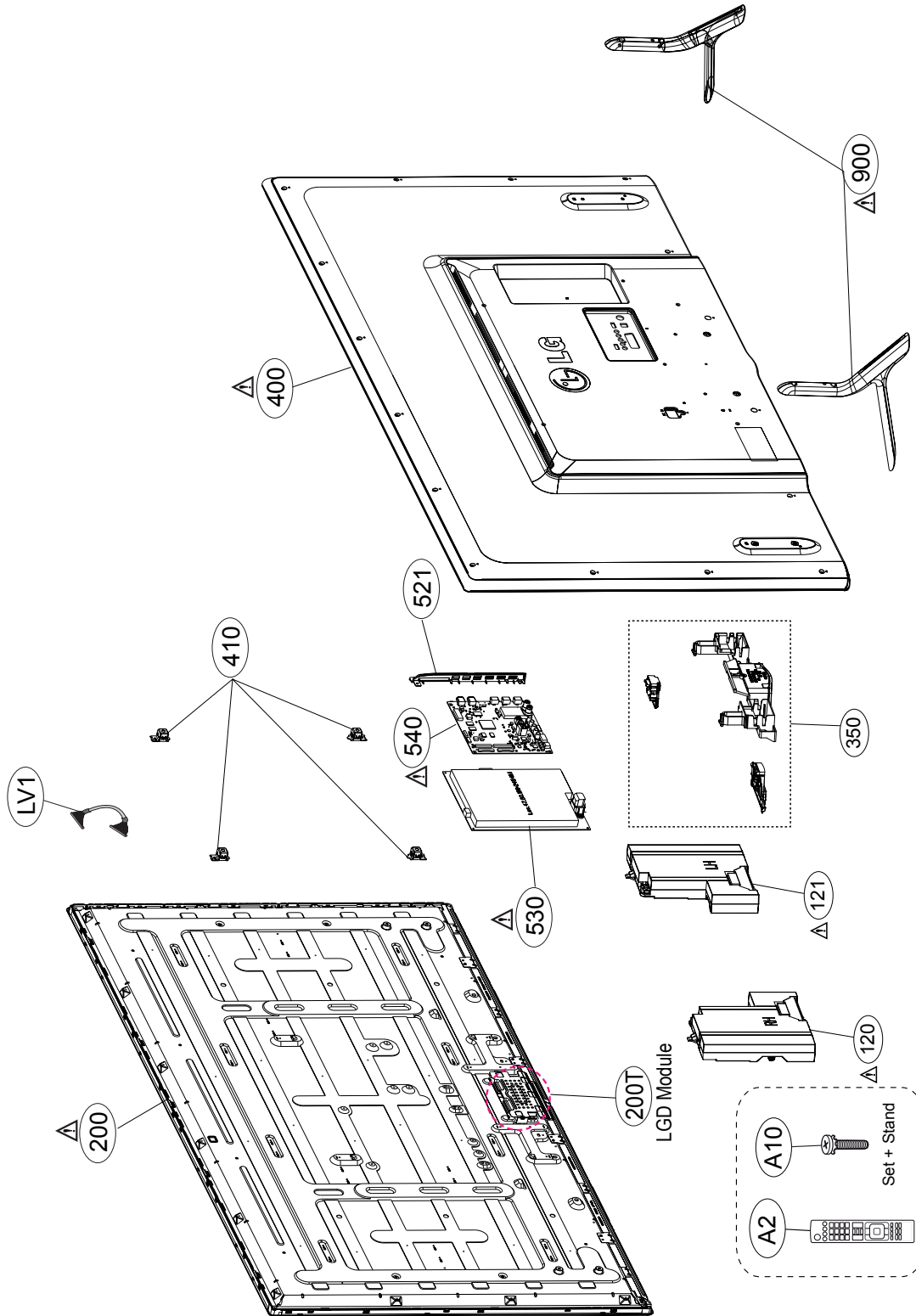

L14 POWER BLOCK (POWER DETECT 2)

FROM LIPS or POWER B/D

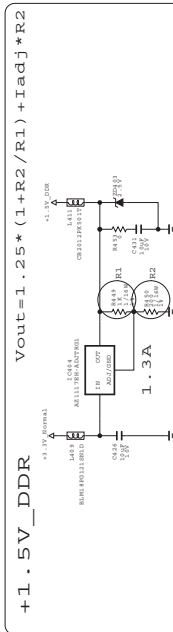
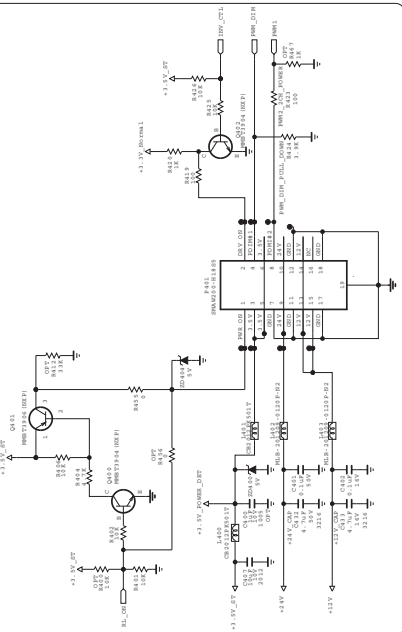

+5V_Normal & +5V_USB with OCP

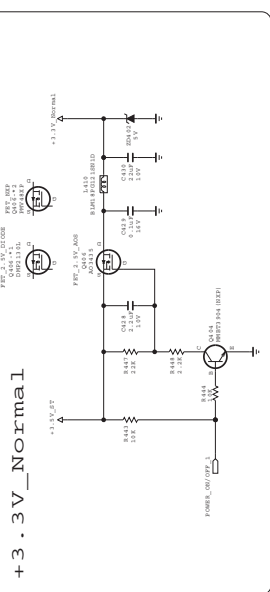
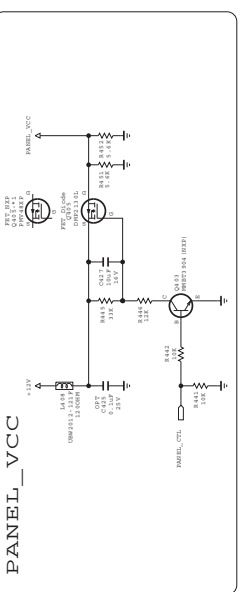
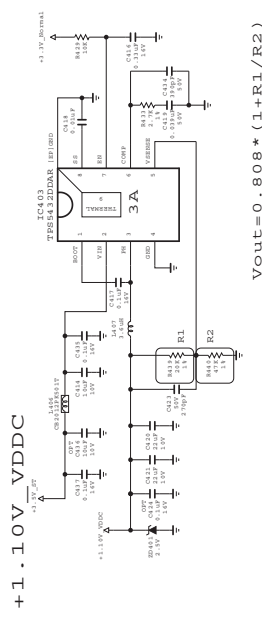
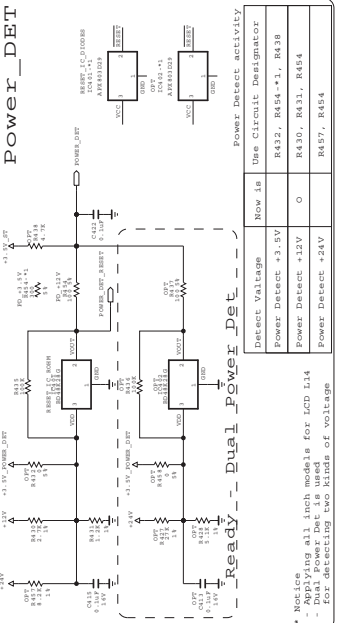
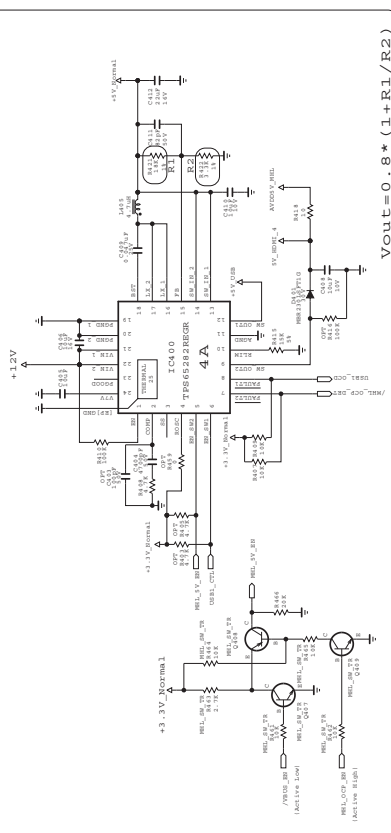

THE SYMBOL MARK OF THIS SCHEMATIC DIAGRAM INCORPORATES SPECIAL FEATURES IMPORTANT FOR PROTECTION FROM X-RADIATION, FIRE AND ELECTRICAL SHOCK HAZARDS. WHEN SERVICING IT IS ESSENTIAL THAT ONLY MANUFACTURERS SPECIFIED PARTS BE USED FOR THE CRITICAL COMPONENTS IN THE SYMBOL MARK OF THE SCHEMATIC.

SECRET
LGElectronics

LG ELECTRONICS

MODEL	L14_M1A	DATE	1.3.11.23
BLOCK	Power_PD2	SHEET	4

HDMI (REAR 1 / SIDE 1 MHL)

HDMI_1

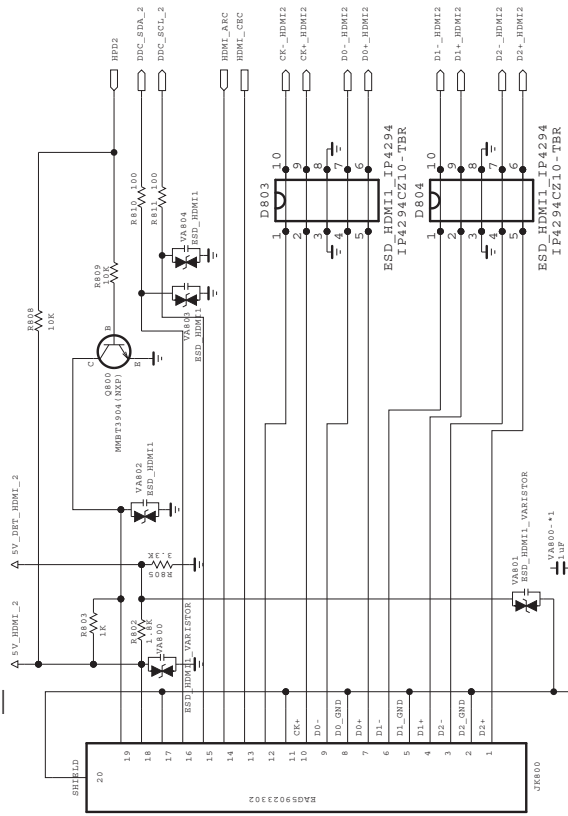

CEC

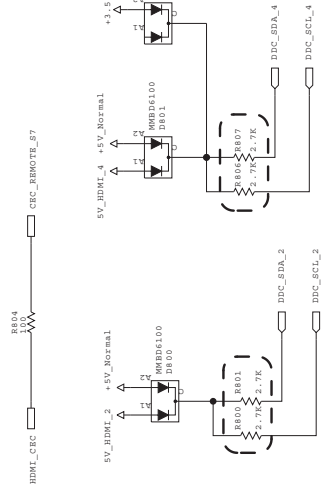

THE Δ SYMBOL MARK OF THIS SCHEMATIC DIAGRAM INCORPORATES SPECIAL FEATURES IMPORTANT FOR PROTECTION FROM X-RADIATION, FIRE AND ELECTRICAL SHOCK HAZARDS, WHEN SERVICING IF IS ESSENTIAL THAT ONLY MANUFACTURERS SPECIFIED PARTS BE USED FOR THE CRITICAL COMPONENTS IN THE Δ SYMBOL MARK OF THE SCHEMATIC.

HDMI_2 MHL

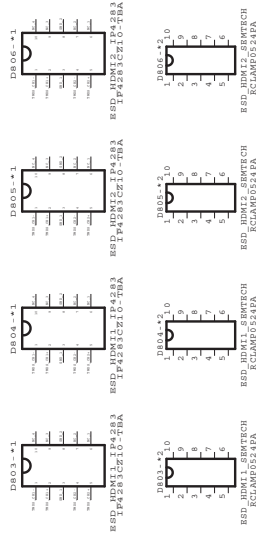
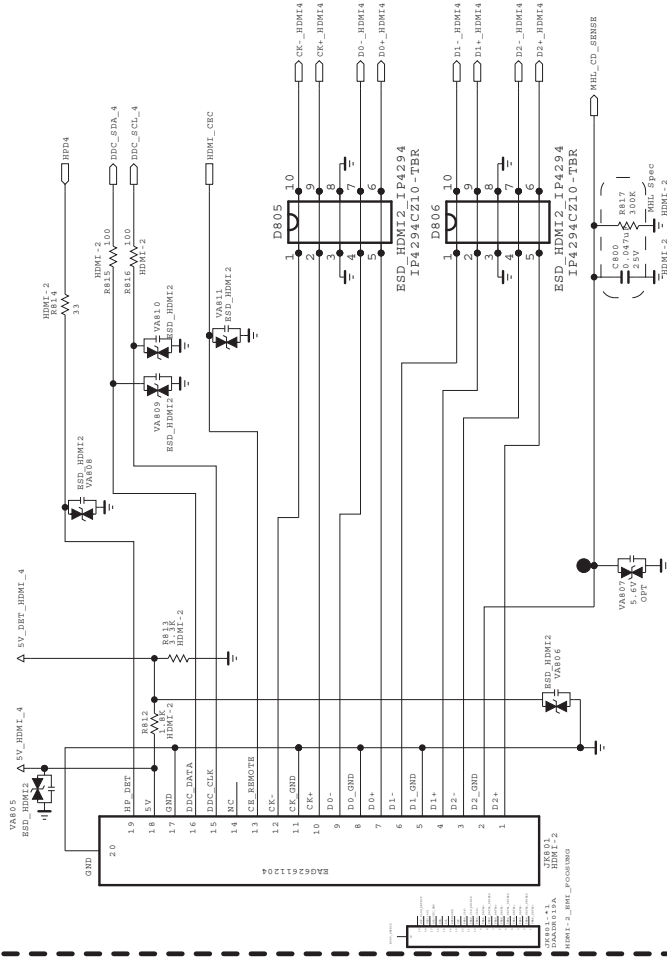

SECRET
LGElectronics

LG ELECTRONICS

MODEL L14_M1A
BLOCK HDMI_R1_S1
DATE 2013/08/15
SHEET 8

SPDIF

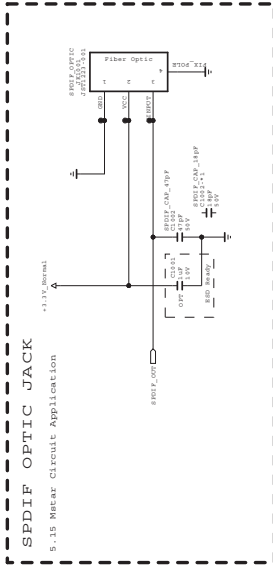

THE SYMBOL MARK OF THIS SCHEMATIC DIAGRAM INCORPORATES SPECIAL FEATURES IMPORTANT FOR PROTECTION FROM X-RADIATION, FIRE AND ELECTRICAL SHOCK HAZARDS. WHEN SERVICING IF IS ESSENTIAL THAT ONLY MANUFACTURERS SPECIFIED PARTS BE USED FOR THE CRITICAL COMPONENTS IN THE SYMBOL MARK OF THE SCHEMATIC.

SECRET
LGElectronics

LG ELECTRONICS

MODEL	NC5_L14	DATE	2013/10/29
BLOCK	SPDIF	SHEET	10

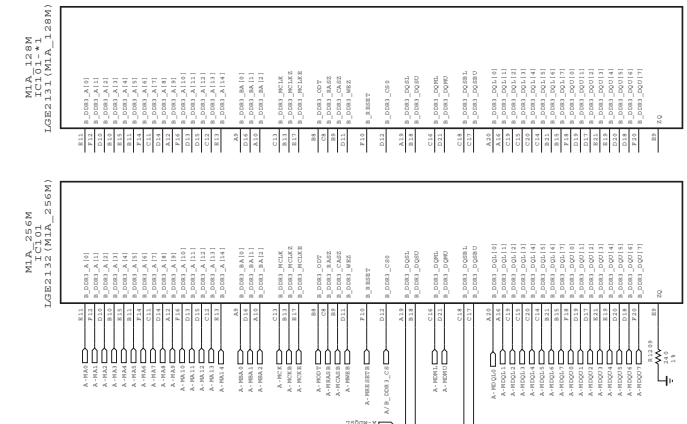
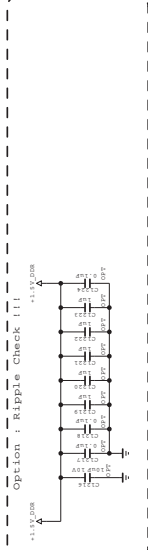
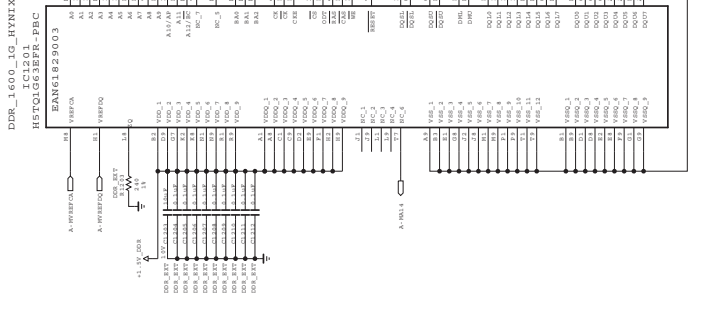
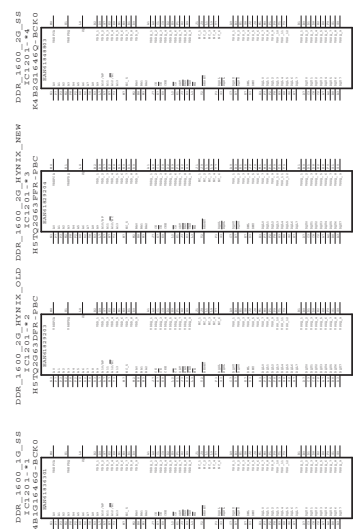
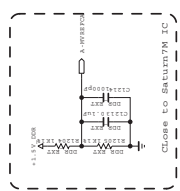
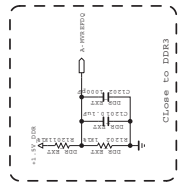

THE SYMBOL MARK OF THIS SCHEMATIC DIAGRAM INCORPORATES SPECIAL FEATURES IMPORTANT FOR PROTECTION FROM X-RADIATION. FIRE AND ELECTRICAL SHOCK HAZARDS, WHEN SERVICING IF IS ESSENTIAL THAT ONLY MANUFACTURERS SPECIFIED PARTS BE USED FOR THE CRITICAL COMPONENTS IN THE SYMBOL MARK OF THE SCHEMATIC.



SECRET
LGElectronics

LG ELECTRONICS

MODEL	NCS_S7LR (M1A)	DATE	2013/05/20
BLOCK	1_DDR	SHEET	12

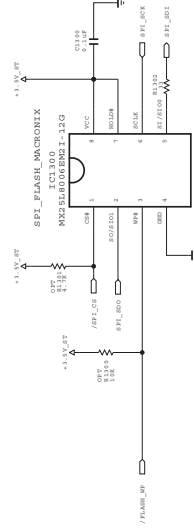
Serial Flash for SPI boot



THE  SYMBOL MARK OF THIS SCHEMATIC DIAGRAM INCORPORATES SPECIAL FEATURES IMPORTANT FOR PROTECTION FROM X-RADIATION, FIRE AND ELECTRICAL SHOCK HAZARDS. WHEN SERVICING IF IS ESSENTIAL THAT ONLY MANUFACTURERS SPECIFIED PARTS BE USED FOR THE CRITICAL COMPONENTS IN THE  SYMBOL MARK OF THE SCHEMATIC.

SECRET
LGElectronics



MODEL	NC5_S7LR (M1A)	DATE	2013/04/29
BLOCK	S_FLASH	SHEET	13

GLOBAL tuner block KR & AJ

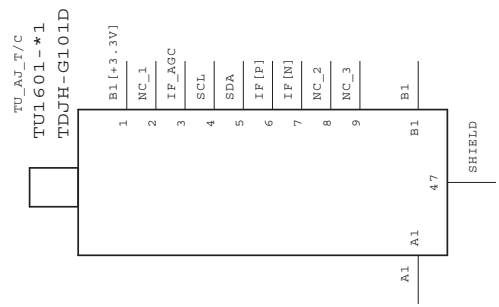
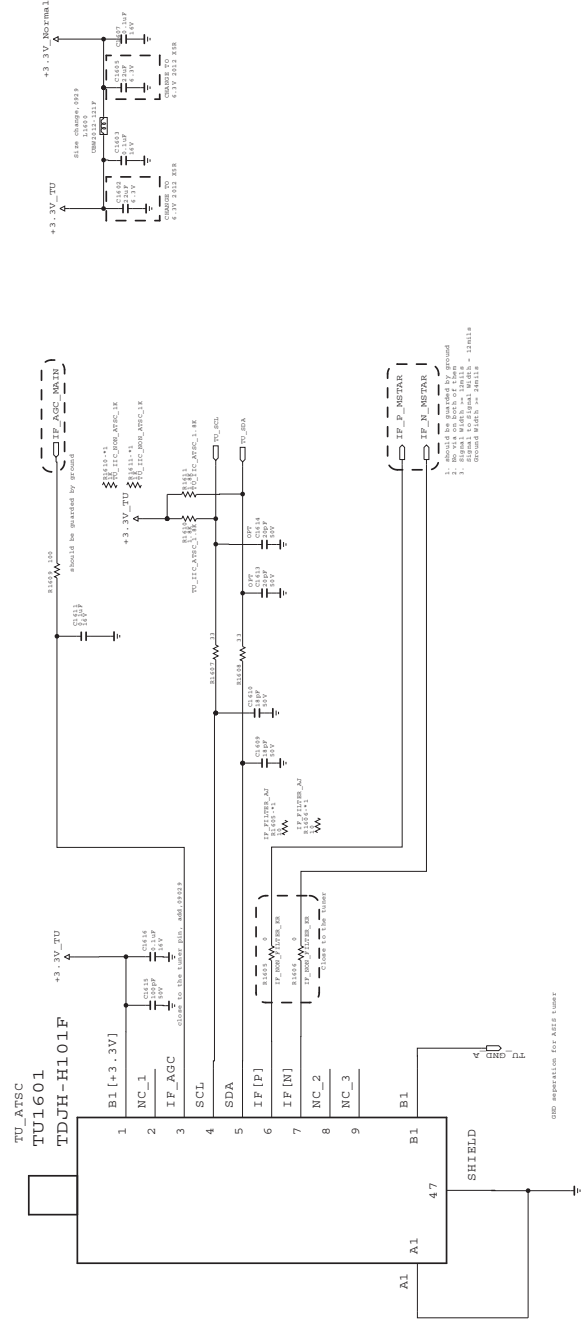

THE SYMBOL MARK OF THIS SCHEMATIC DIAGRAM INCORPORATES SPECIAL FEATURES IMPORTANT FOR PROTECTION FROM X-RADIATION, FIRE AND ELECTRICAL SHOCK HAZARDS. WHEN SERVICING IF IS ESSENTIAL THAT ONLY MANUFACTURERS SPECIFIED PARTS BE USED FOR THE CRITICAL COMPONENTS IN THE SYMBOL MARK OF THE SCHEMATIC.

SECRET
LGElectronics



MODEL	L14_M1A	DATE	2013/06/05
BLOCK	TUNER_KR_AJ	SHEET	16

COMPONENT & AV1 (COMMON) , AV2

COMP_AV1/2_YG
JKI701
PFJ248-21

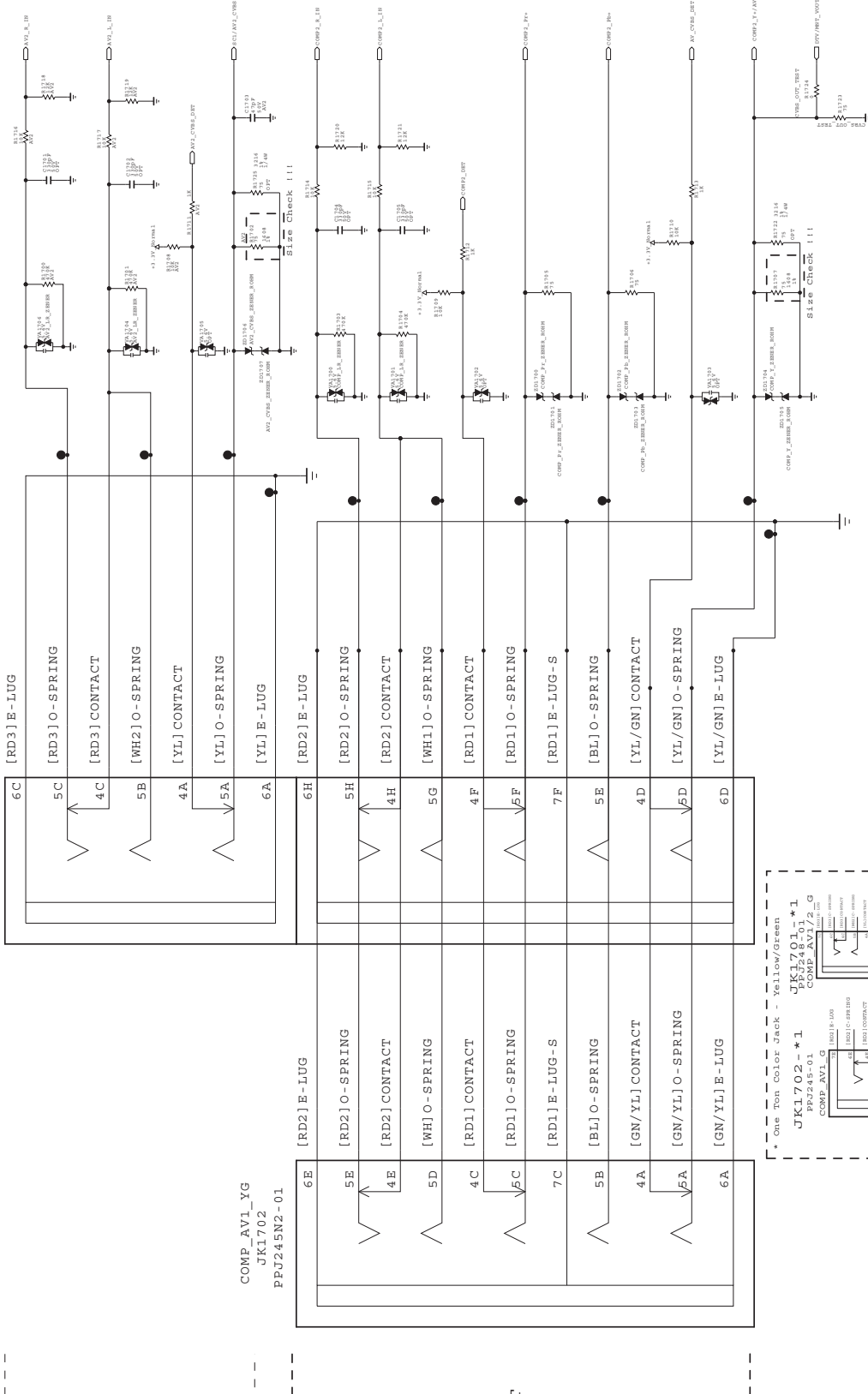

AV2

COMPONENT & AV1

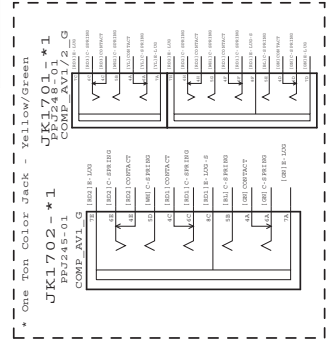

THE SYMBOL MARK OF THIS SCHEMATIC DIAGRAM INCORPORATES SPECIAL FEATURES IMPORTANT FOR PROTECTION FROM X-RADIATION. FIRE AND ELECTRICAL SHOCK HAZARDS. WHEN SERVICING IF IS ESSENTIAL THAT ONLY MANUFACTURERS SPECIFIED PARTS BE USED FOR THE CRITICAL COMPONENTS IN THE SYMBOL MARK OF THE SCHEMATIC.

MODEL	L14	S7LR (MIA)	DATE	2013.08.15
BLOCK	REAR_JACK_NON_BU	SHEET	1.7	



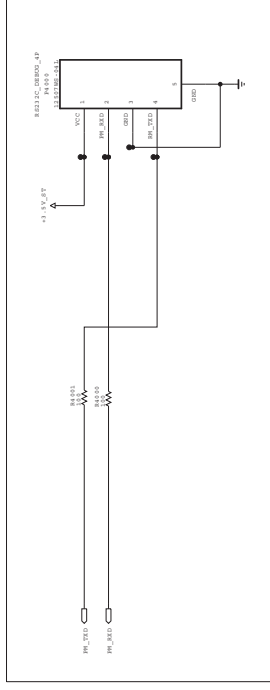

RS-232C 4PIN & MSTAR DEBUG 4PIN

RS-232C 4PIN

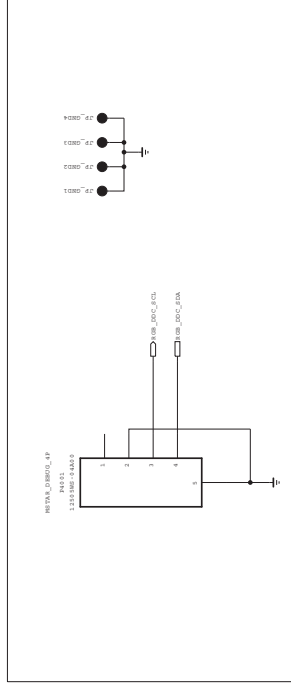

MSTAR DEBUG 4PIN



THE  SYMBOL MARK OF THIS SCHEMATIC DIAGRAM INCORPORATES SPECIAL FEATURES IMPORTANT FOR PROTECTION FROM X-RADIATION, FIRE AND ELECTRICAL SHOCK HAZARDS. WHEN SERVICING IF IS ESSENTIAL THAT ONLY MANUFACTURERS SPECIFIED PARTS BE USED FOR THE CRITICAL COMPONENTS IN THE  SYMBOL MARK OF THE SCHEMATIC.

SECRET
LGElectronics

 **LG ELECTRONICS**

MODEL	L14_S7LR (M1A)	DATE	2013/04/30
BLOCK	R8232C_MSTAR_DEBUG_4P	SHEET	4 0

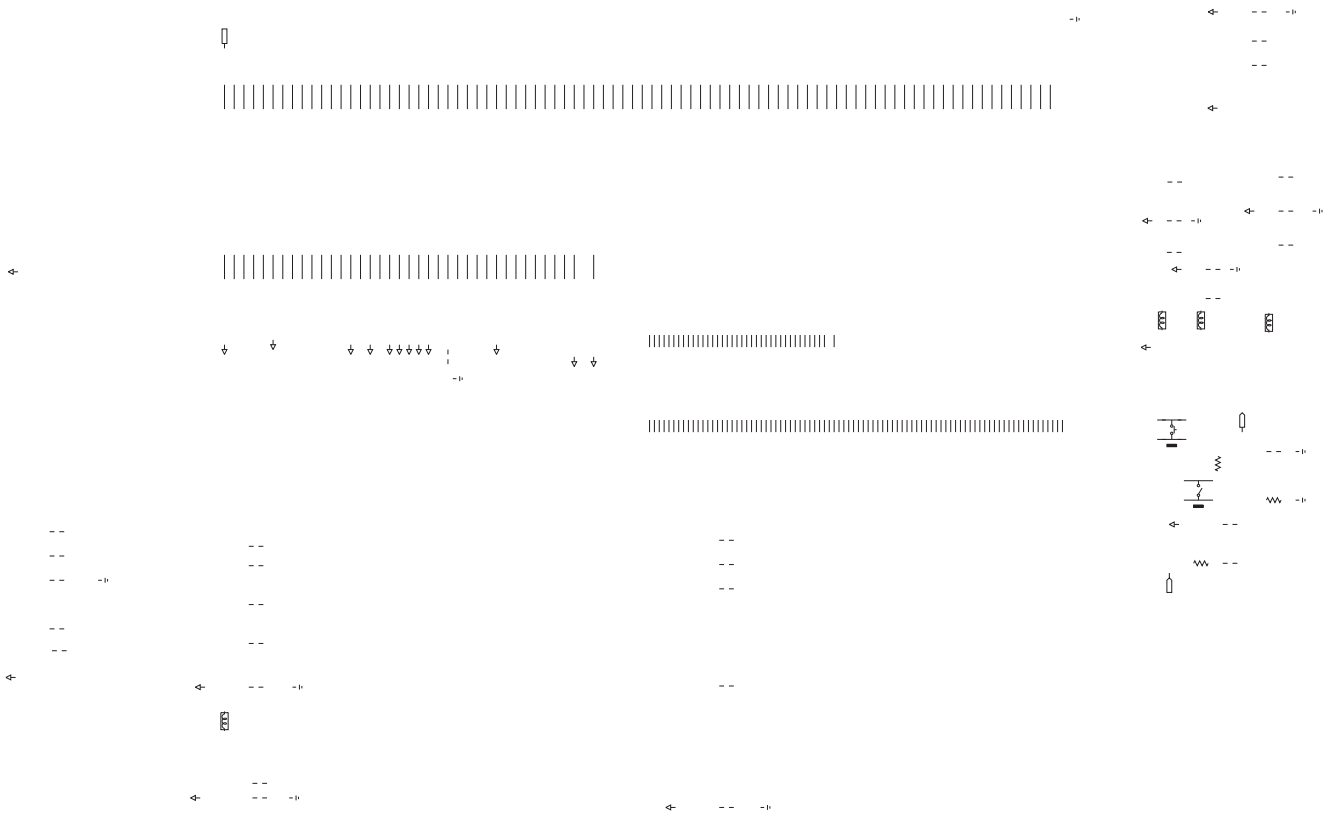

0000

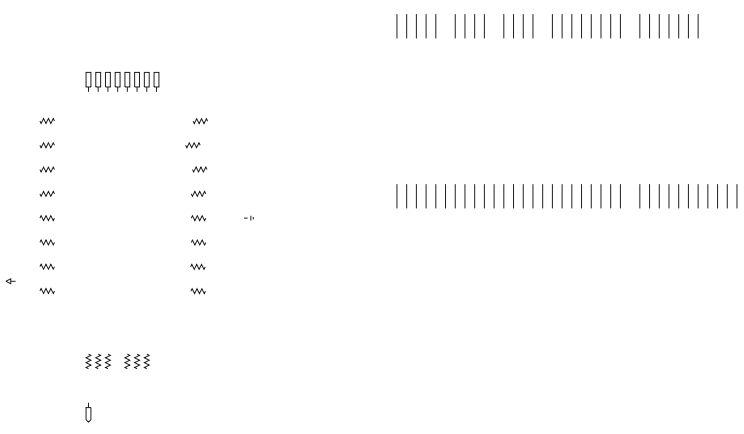
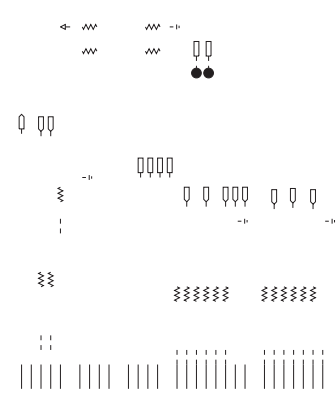



L14 MHL SW AND GATE

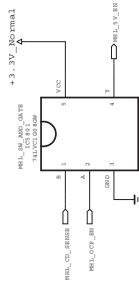

THE SYMBOL MARK OF THIS SCHEMATIC DIAGRAM INCORPORATES SPECIAL FEATURES IMPORTANT FOR PROTECTION FROM X-RADIATION, FIRE AND ELECTRICAL SHOCK HAZARDS, WHEN SERVICING IF IS ESSENTIAL THAT ONLY MANUFACTURERS SPECIFIED PARTS BE USED FOR THE CRITICAL COMPONENTS IN THE SYMBOL MARK OF THE SCHEMATIC.

SECRET
LGElectronics

LG ELECTRONICS

MODEL	L14_M1A	DATE	2013.09.01
BLOCK	MHL_SW_AND	SHEET	58 /

