



North/Latin America  
Europe/Africa  
Asia/Oceania

Internal Use Only

<http://aic.lgservice.com>  
<http://eic.lgservice.com>  
<http://biz.lgservice.com>

# LCD TV

# SERVICE MANUAL

CHASSIS : LJ03B

MODEL : 32LD650 32LD650-SA

## CAUTION

BEFORE SERVICING THE CHASSIS,  
READ THE SAFETY PRECAUTIONS IN THIS MANUAL.

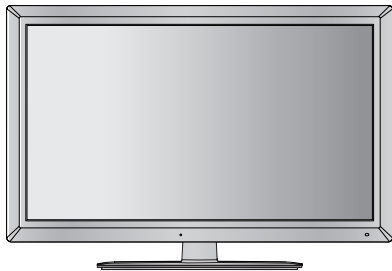

# CONTENTS

**CONTENTS ..... 2**

**PRODUCT SAFETY ..... 3**

**SPECIFICATION ..... 6**

**ADJUSTMENT INSTRUCTION ..... 12**

**EXPLODED VIEW ..... 20**

**SVC. SHEET .....**

# SAFETY PRECAUTIONS

## IMPORTANT SAFETY NOTICE

Many electrical and mechanical parts in this chassis have special safety-related characteristics. These parts are identified by  $\triangle$  in the Schematic Diagram and Exploded View.

It is essential that these special safety parts should be replaced with the same components as recommended in this manual to prevent Shock, Fire, or other Hazards.

Do not modify the original design without permission of manufacturer.

### General Guidance

An **isolation Transformer should always be used** during the servicing of a receiver whose chassis is not isolated from the AC power line. Use a transformer of adequate power rating as this protects the technician from accidents resulting in personal injury from electrical shocks.

It will also protect the receiver and its components from being damaged by accidental shorts of the circuitry that may be inadvertently introduced during the service operation.

If any fuse (or Fusible Resistor) in this TV receiver is blown, replace it with the specified.

When replacing a high wattage resistor (Oxide Metal Film Resistor, over 1 W), keep the resistor 10 mm away from PCB.

Keep wires away from high voltage or high temperature parts.

### Before returning the receiver to the customer,

always perform an **AC leakage current check** on the exposed metallic parts of the cabinet, such as antennas, terminals, etc., to be sure the set is safe to operate without damage of electrical shock.

### Leakage Current Cold Check(Antenna Cold Check)

With the instrument AC plug removed from AC source, connect an electrical jumper across the two AC plug prongs. Place the AC switch in the on position, connect one lead of ohm-meter to the AC plug prongs tied together and touch other ohm-meter lead in turn to each exposed metallic parts such as antenna terminals, phone jacks, etc.

If the exposed metallic part has a return path to the chassis, the measured resistance should be between  $1\text{ M}\Omega$  and  $5.2\text{ M}\Omega$ .

When the exposed metal has no return path to the chassis the reading must be infinite.

An other abnormality exists that must be corrected before the receiver is returned to the customer.

### Leakage Current Hot Check (See below Figure)

Plug the AC cord directly into the AC outlet.

### Do not use a line Isolation Transformer during this check.

Connect 1.5 K / 10 watt resistor in parallel with a 0.15  $\mu\text{F}$  capacitor between a known good earth ground (Water Pipe, Conduit, etc.) and the exposed metallic parts.

Measure the AC voltage across the resistor using AC voltmeter with 1000 ohms/volt or more sensitivity.

Reverse plug the AC cord into the AC outlet and repeat AC voltage measurements for each exposed metallic part. Any voltage measured must not exceed 0.75 volt RMS which corresponds to 0.5 mA.

In case any measurement is out of the limits specified, there is possibility of shock hazard and the set must be checked and repaired before it is returned to the customer.

### Leakage Current Hot Check circuit

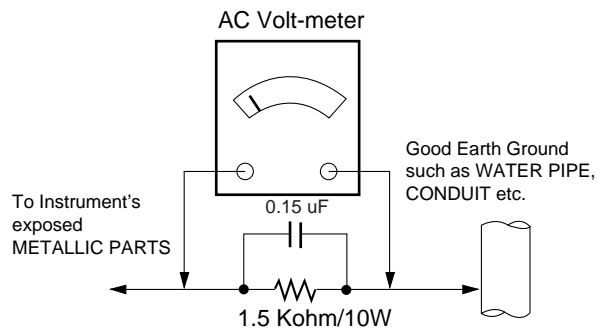

When 25A is impressed between Earth and 2nd Ground for 1 second, Resistance must be less than  $0.1\ \Omega$

\*Base on Adjustment standard

# SERVICING PRECAUTIONS

**CAUTION:** Before servicing receivers covered by this service manual and its supplements and addenda, read and follow the *SAFETY PRECAUTIONS* on page 3 of this publication.

**NOTE:** If unforeseen circumstances create conflict between the following servicing precautions and any of the safety precautions on page 3 of this publication, always follow the safety precautions. Remember: Safety First.

## General Servicing Precautions

1. Always unplug the receiver AC power cord from the AC power source before;
  - a. Removing or reinstalling any component, circuit board module or any other receiver assembly.
  - b. Disconnecting or reconnecting any receiver electrical plug or other electrical connection.
  - c. Connecting a test substitute in parallel with an electrolytic capacitor in the receiver.

**CAUTION:** A wrong part substitution or incorrect polarity installation of electrolytic capacitors may result in an explosion hazard.

2. Test high voltage only by measuring it with an appropriate high voltage meter or other voltage measuring device (DVM, FETVOM, etc) equipped with a suitable high voltage probe. Do not test high voltage by "drawing an arc".

3. Do not spray chemicals on or near this receiver or any of its assemblies.

4. Unless specified otherwise in this service manual, clean electrical contacts only by applying the following mixture to the contacts with a pipe cleaner, cotton-tipped stick or comparable non-abrasive applicator; 10 % (by volume) Acetone and 90 % (by volume) isopropyl alcohol (90 % - 99 % strength)

**CAUTION:** This is a flammable mixture.

Unless specified otherwise in this service manual, lubrication of contacts is not required.

5. Do not defeat any plug/socket B+ voltage interlocks with which receivers covered by this service manual might be equipped.

6. Do not apply AC power to this instrument and/or any of its electrical assemblies unless all solid-state device heat sinks are correctly installed.

7. Always connect the test receiver ground lead to the receiver chassis ground before connecting the test receiver positive lead.

Always remove the test receiver ground lead last.

8. Use with this receiver only the test fixtures specified in this service manual.

**CAUTION:** Do not connect the test fixture ground strap to any heat sink in this receiver.

## Electrostatically Sensitive (ES) Devices

Some semiconductor (solid-state) devices can be damaged easily by static electricity. Such components commonly are called *Electrostatically Sensitive (ES) Devices*. Examples of typical ES devices are integrated circuits and some field-effect transistors and semiconductor "chip" components. The following techniques should be used to help reduce the incidence of component damage caused by static by static electricity.

1. Immediately before handling any semiconductor component or semiconductor-equipped assembly, drain off any electrostatic charge on your body by touching a known earth ground. Alternatively, obtain and wear a commercially available discharging wrist strap device, which should be removed to prevent potential shock reasons prior to applying power to the unit under test.

2. After removing an electrical assembly equipped with ES devices, place the assembly on a conductive surface such as aluminum foil, to prevent electrostatic charge buildup or exposure of the assembly.

3. Use only a grounded-tip soldering iron to solder or unsolder ES devices.

4. Use only an anti-static type solder removal device. Some solder removal devices not classified as "anti-static" can generate electrical charges sufficient to damage ES devices.

5. Do not use freon-propelled chemicals. These can generate electrical charges sufficient to damage ES devices.

6. Do not remove a replacement ES device from its protective package until immediately before you are ready to install it. (Most replacement ES devices are packaged with leads electrically shorted together by conductive foam, aluminum foil or comparable conductive material).

7. Immediately before removing the protective material from the leads of a replacement ES device, touch the protective material to the chassis or circuit assembly into which the device will be installed.

**CAUTION:** Be sure no power is applied to the chassis or circuit, and observe all other safety precautions.

8. Minimize bodily motions when handling unpackaged replacement ES devices. (Otherwise harmless motion such as the brushing together of your clothes fabric or the lifting of your foot from a carpeted floor can generate static electricity sufficient to damage an ES device.)

## General Soldering Guidelines

1. Use a grounded-tip, low-wattage soldering iron and appropriate tip size and shape that will maintain tip temperature within the range of 500 °F to 600 °F.

2. Use an appropriate gauge of RMA resin-core solder composed of 60 parts tin/40 parts lead.

3. Keep the soldering iron tip clean and well tinned.

4. Thoroughly clean the surfaces to be soldered. Use a mall wire-bristle (0.5 inch, or 1.25 cm) brush with a metal handle. Do not use freon-propelled spray-on cleaners.

5. Use the following unsoldering technique

- a. Allow the soldering iron tip to reach normal temperature. (500 °F to 600 °F)

- b. Heat the component lead until the solder melts.

- c. Quickly draw the melted solder with an anti-static, suction-type solder removal device or with solder braid.

**CAUTION:** Work quickly to avoid overheating the circuit board printed foil.

6. Use the following soldering technique.

- a. Allow the soldering iron tip to reach a normal temperature (500 °F to 600 °F)

- b. First, hold the soldering iron tip and solder the strand against the component lead until the solder melts.

- c. Quickly move the soldering iron tip to the junction of the component lead and the printed circuit foil, and hold it there only until the solder flows onto and around both the component lead and the foil.

**CAUTION:** Work quickly to avoid overheating the circuit board printed foil.

- d. Closely inspect the solder area and remove any excess or splashed solder with a small wire-bristle brush.

### IC Remove/Replacement

Some chassis circuit boards have slotted holes (oblong) through which the IC leads are inserted and then bent flat against the circuit foil. When holes are the slotted type, the following technique should be used to remove and replace the IC. When working with boards using the familiar round hole, use the standard technique as outlined in paragraphs 5 and 6 above.

#### Removal

1. Desolder and straighten each IC lead in one operation by gently prying up on the lead with the soldering iron tip as the solder melts.
2. Draw away the melted solder with an anti-static suction-type solder removal device (or with solder braid) before removing the IC.

#### Replacement

1. Carefully insert the replacement IC in the circuit board.
2. Carefully bend each IC lead against the circuit foil pad and solder it.
3. Clean the soldered areas with a small wire-bristle brush. (It is not necessary to reapply acrylic coating to the areas).

### "Small-Signal" Discrete Transistor

#### Removal/Replacement

1. Remove the defective transistor by clipping its leads as close as possible to the component body.
2. Bend into a "U" shape the end of each of three leads remaining on the circuit board.
3. Bend into a "U" shape the replacement transistor leads.
4. Connect the replacement transistor leads to the corresponding leads extending from the circuit board and crimp the "U" with long nose pliers to insure metal to metal contact then solder each connection.

### Power Output, Transistor Device

#### Removal/Replacement

1. Heat and remove all solder from around the transistor leads.
2. Remove the heat sink mounting screw (if so equipped).
3. Carefully remove the transistor from the heat sink of the circuit board.
4. Insert new transistor in the circuit board.
5. Solder each transistor lead, and clip off excess lead.
6. Replace heat sink.

### Diode Removal/Replacement

1. Remove defective diode by clipping its leads as close as possible to diode body.
2. Bend the two remaining leads perpendicular y to the circuit board.
3. Observing diode polarity, wrap each lead of the new diode around the corresponding lead on the circuit board.
4. Securely crimp each connection and solder it.
5. Inspect (on the circuit board copper side) the solder joints of the two "original" leads. If they are not shiny, reheat them and if necessary, apply additional solder.

### Fuse and Conventional Resistor

#### Removal/Replacement

1. Clip each fuse or resistor lead at top of the circuit board hollow stake.
2. Securely crimp the leads of replacement component around notch at stake top.
3. Solder the connections.  
**CAUTION:** Maintain original spacing between the replaced component and adjacent components and the circuit board to prevent excessive component temperatures.

### Circuit Board Foil Repair

Excessive heat applied to the copper foil of any printed circuit board will weaken the adhesive that bonds the foil to the circuit board causing the foil to separate from or "lift-off" the board. The following guidelines and procedures should be followed whenever this condition is encountered.

#### At IC Connections

To repair a defective copper pattern at IC connections use the following procedure to install a jumper wire on the copper pattern side of the circuit board. (Use this technique only on IC connections).

1. Carefully remove the damaged copper pattern with a sharp knife. (Remove only as much copper as absolutely necessary).
2. Carefully scratch away the solder resist and acrylic coating (if used) from the end of the remaining copper pattern.
3. Bend a small "U" in one end of a small gauge jumper wire and carefully crimp it around the IC pin. Solder the IC connection.
4. Route the jumper wire along the path of the out-away copper pattern and let it overlap the previously scraped end of the good copper pattern. Solder the overlapped area and clip off any excess jumper wire.

#### At Other Connections

Use the following technique to repair the defective copper pattern at connections other than IC Pins. This technique involves the installation of a jumper wire on the component side of the circuit board.

1. Remove the defective copper pattern with a sharp knife. Remove at least 1/4 inch of copper, to ensure that a hazardous condition will not exist if the jumper wire opens.
2. Trace along the copper pattern from both sides of the pattern break and locate the nearest component that is directly connected to the affected copper pattern.
3. Connect insulated 20-gauge jumper wire from the lead of the nearest component on one side of the pattern break to the lead of the nearest component on the other side. Carefully crimp and solder the connections.  
**CAUTION:** Be sure the insulated jumper wire is dressed so the it does not touch components or sharp edges.

# SPECIFICATION

NOTE : Specifications and others are subject to change without notice for improvement.

## 1. Application range

This specification is applied to the LCD TV used LJ03B/D/E/F chassis.

## 2. Requirement for Test

Each part is tested as below without special appointment.

- 1) Temperature  
:  $25\text{ }^{\circ}\text{C} \pm 5\text{ }^{\circ}\text{C}$  ( $77\text{ }^{\circ}\text{F} \pm 9\text{ }^{\circ}\text{F}$ ), CST :  $40\text{ }^{\circ}\text{C} \pm 5\text{ }^{\circ}\text{C}$
- 2) Relative Humidity :  $65\% \pm 10\%$
- 3) Power Voltage  
: Standard input voltage (AC 100-240 V~ 50 / 60 Hz)  
\* Standard Voltage of each products is marked by models.
- 4) Specification and performance of each parts are followed each drawing and specification by part number in accordance with BOM.
- 5) The receiver must be operated for about 20 minutes prior to the adjustment.

## 3. Test method

- 1) Performance: LGE TV test method followed
- 2) Demanded other specification
  - Safety: CE, IEC specification
  - EMC:CE, IEC

## 4. General Specification(TV)

No	Item	Specification	Remark
1	Receivable System	1) SBTVD / NTSC / PAL-M / PAL-N	
2	Available Channel	VHF : 02 ~ 13 UHF : 14 ~ 69 DTV : 07 ~ 69 CATV : 01 ~ 135	
3	Input Voltage	1) AC 100 ~ 240V 50/60Hz	
4	Market	Central and South AMERICA	
5	Screen Size	32 inch Wide (1920 x 1080) 42 inch Wide (1920 x 1080) 47 inch Wide (1920 x 1080) 55 inch Wide (1920 x 1080) 60 inch Wide (1920 x 1080)	32LE7500,32LD650,32LE5500 42LE7500,42LD650,42LE5500,42LE8500 47LE7500,47LD650,47LE5500, 55LE7500,55LD650 60LE5500
6	Aspect Ratio	16:9	
7	Tuning System	FS	
8	LCD Module	LC320EUH-SCA4 (Vitiaz 5) LC420EUH-SCA2 (Vitiaz 5) LC470EUH-SCA2 (Vitiaz 5) LC550EUB-SCA2 (Vitiaz 5) LC320WUH-SCA1(Vitiaz 5) LC420WUH-SCA1(Vitiaz 5) LC470WUH-SCA1(Vitiaz 5) LC550WUB-SCA1(Vitiaz 5) LC320EUH-SCA1(Vitiaz 5) LC420EUH-SCA1(Vitiaz 5) LC470EUH-SCA1(Vitiaz 5) Sharp 60 FHD T240 IOP LED LC420MUK-SCA1 (Vitiaz 5)	32LE7500-SA 42LE7500-SA 47LE7500-SA 55LE7500-SA 32LD650-SA 42LD650-SA 47LD650-SA 55LD650-SA 32LE5500-SA 42LE5500-SA 47LE5500-SA 60LE5500-SA 42LE8500-SA
9	Operating Environment	Temp : 0 ~ 40 deg Humidity : ~ 80 %	
10	Storage Environment	Temp : -20 ~ 60 deg Humidity : -85 %	

## 5. Chrominance & Luminance Specification

### 1) LJ03D/E (LE5500,LE7500,42LE8500)

No	Item			Min	Typ	Max	Unit	Remark						
1.	Max Luminance (Center 1-point / Full White Pattern)	Module		360 450	450 500		cd/m <sup>2</sup>	32/42/47/55LE7(5)500 42LE8500						
		Set		300 400	450 500		cd/m <sup>2</sup>	32/42/47/55LE7(5)500 42LE8500						
2.	Luminance uniformity			77			%	Full white						
3.	Color coordinate	RED	X	Typ. -0.03	0.651 0.647 0.645 (TBD)	Typ. +0.03		32LE7(5)500 42/55LE7(5)500 47LE7(5)500 (42LE8500)						
			Y		0.332 0.332 0.333 (TBD)									
		GREEN	X		0.308 0.309 0.310 (TBD)									
			Y		0.597 0.601 0.593 (TBD)									
		BLUE	X		0.149 0.149 0.152 (TBD)									
			Y		0.059 0.059 0.057 (TBD)									
		WHITE	X		0.279 (0.280)									
			Y		0.292 (0.290)									
		4.	Color coordinate uniformity									N/A		
		5.	Contrast ratio				900:1 1000:1		1300:1 1400:1			32LE7(5)500 42/47/55, 42LE85	NORMAL	
							3,000,000:1 5,000,000:1		5,000,000:1 7,000,000:1			LE7(5)500 42LE8500	DCR	
		6.	Color Temperature		Cool				0.267 0.271	0.269 0.273	0.271 0.275		<Test Condition> 85% Full white pattern ** The W/B Tolerance is ±0.015 Adjustment	
Standard				0.283 0.291	0.285 0.293	0.287 0.295								
Warm				0.311 0.327	0.313 0.329	0.315 0.331								
7.	Color Distortion, DG					10.0	%							
8.	Color Distortion, DP					10.0	deg							
9.	Color S/N, AM/FM			43.0			dB							
10.	Color Killer Sensitivity			-80			dBm							

2) LJ03B (32/42/47/55LD650-SA)

No	Item			Min	Typ	Max	Unit	Remark
1.	Max Luminance (Center 1-point / Full White Pattern)	Module		400	500		cd/m <sup>2</sup>	32/42/47/55LD650
		Set		400	500		cd/m <sup>2</sup>	32/42/47/55LD650
2.	Luminance uniformity			77			%	Full white
3.	Color coordinate	RED	X	Typ. -0.03	0.642	Typ. +0.03		32LD650 42LD650 47LD650 55LD650
			Y		0.636			
		GREEN	X		0.639			
					(TBD)			
			Y		0.334			
					(TBD)			
		BLUE	X		0.335			
					(TBD)			
			Y		0.334			
					(TBD)			
		WHITE	X		0.292			
					(TBD)			
Y	0.291							
	(TBD)							
Y	0.607							
	(TBD)							
Y	0.603							
	(TBD)							
Y	0.606							
	(TBD)							
Y	0.146							
	(TBD)							
Y	0.056							
	(TBD)							
Y	0.061							
	(TBD)							
Y	0.058							
	(TBD)							
Y	0.279							
	(TBD)							
Y	0.292							
	(TBD)							
4.	Color coordinate uniformity							N/A
5.	Contrast ratio			1000:1	1400:1			32LD650
				1100:1	1500:1			42/55LD650
				1200:1	1500:1			47LD650
				50,000:1	70,000:1			DCR
6.	Color Temperature	Cool		0.267	0.269	0.271		<Test Condition> 85% Full white pattern ** The W/B Tolerance is ±0.015 Adjustment
				0.271	0.273	0.275		
		Standard		0.283	0.285	0.287		
				0.291	0.293	0.295		
		Warm		0.311	0.313	0.315		
				0.327	0.329	0.331		
7.	Color Distortion, DG					10.0	%	
8.	Color Distortion, DP					10.0	deg	
9.	Color S/N, AM/FM			43.0			dB	
10.	Color Killer Sensitivity			-80			dBm	

## 6. Component Video Input (Y, CB/PB, CR/PR)

No	Resolution	H-freq(kHz)	V-freq.(kHz)	Pixel clock	Proposed
1.	720*480	15.73	60	13.5135	SDTV ,DVD 480I
2.	720*480	15.73	59.94	13.5	SDTV ,DVD 480I
3.	720*480	31.50	60	27.027	SDTV 480P
4.	720*480	31.47	59.94	27.00	SDTV 480P
5.	720*576	15.625	50*	13.5	SDTV 576I
6.	720*576	31.25	50*	13.5	SDTV 576P
7.	1280*720	37.5	50*	74.25	HDTV 720P
8.	1280*720	45.00	60.00	74.25	HDTV 720P
9.	1280*720	44.96	59.94	74.176	HDTV 720P
10.	1929*1080	28.125	50*	74.25	HDTV 1080I
11.	1920*1080	33.75	60.00	74.25	HDTV 1080I
12.	1920*1080	33.72	59.94	74.176	HDTV 1080I
13.	1920*1080	56.25	50*	148.5	HDTV 1080P
14.	1920*1080	67.50	60	148.50	HDTV 1080P
15.	1920*1080	67.432	59.94	148.352	HDTV 1080P
16.	1920*1080	27.00	24.00	74.25	HDTV 1080P
17.	1920*1080	26.97	23.976	74.176	HDTV 1080P
18.	1920*1080	33.75	30.00	74.25	HDTV 1080P
19.	1920*1080	33.71	29.97	74.176	HDTV 1080P

## 8. RGB Input (PC)

No	Resolution	H-freq(kHz)	V-freq.(kHz)	Pixel clock	Proposed	
	PC					DDC
1.	640*350	31.468	70.09	25.17	EGA	X
2.	720*400	31.469	70.08	28.32	DOS	O
3.	640*480	31.469	59.94	25.17	VESA(VGA)	O
4.	800*600	37.879	60.31	40.00	VESA(SVGA)	O
5.	1024*768	48.363	60.00	65.00	VESA(XGA)	O
6.	1280*768	47.776	59.87	79.50	CVT(WXGA)	O
7.	1360*768	47.712	60.015	85.50	VESA(WXGA)	O
8.	1280*1024	63.981	60.020	108.00	VESA(SXGA)	O
9.	1600*1200	75.00	60.00	162	VESA(UXGA)	O
10.	1920*1080	67.50	60	148.5	HDTV 1080P	O

- RGB PC Monitor Range Limits
  - Min Vertical Freq - 56 Hz
  - Max Vertical Freq - 62 Hz
  - Min Horiz. Freq - 30 kHz
  - Max Horiz. Freq - 80 kHz
  - Pixel Clock - 170 MHz

## 9. HDMI input (PC/DTV)

No	Resolution	H-freq(kHz)	V-freq.(kHz)	Pixel clock	Proposed	
	PC					DDC
1.	640*350	31.468	70.09	25.17	EGA	X
2.	720*400	31.469	70.08	28.32	DOS	O
3.	640*480	31.469	59.94	25.17	VESA(VGA)	O
4.	800*600	37.879	60.31	40.00	VESA(SVGA)	O
5.	1024*768	48.363	60.00	65.00	VESA(XGA)	O
6.	1280*768	47.776	59.870	79.50	CVT(WXGA)	X
7.	1360*768	47.712	60.015	85.50	VESA(WXGA)	X
8.	1280*1024	63.981	60.020	108.00	VESA(SXGA)	O
9.	1600*1200	75.00	60.00	162	VESA(UXGA)	O
10.	1920*1080	67.5	60	148.5	HDTV 1080P	O
	DTV					
1.	720*480	31.50	60	27.027	SDTV 480P	
2.	720*480	31.47	59.94	27.00	SDTV 480P	
3.	720*576	31.25	50*	13.5	SDTV 576P	
4.	1280*720	37.5	50*	74.25	HDTV 720P	
5.	1280*720	45.00	60.00	74.25	HDTV 720P	
6.	1280*720	44.96	59.94	74.176	HDTV 720P	
7.	1929*1080	28.125	50*	74.25	HDTV 1080I	
8.	1920*1080	33.75	60.00	74.25	HDTV 1080I	
9.	1920*1080	33.72	59.94	74.176	HDTV 1080I	
10.	1920*1080	56.25	50*	148.5	HDTV 1080P	
11.	1920*1080	67.50	60	148.50	HDTV 1080P	
12.	1920*1080	67.432	59.94	148.352	HDTV 1080P	
13.	1920*1080	27.00	24.00	74.25	HDTV 1080P	
14.	1920*1080	26.97	23.976	74.176	HDTV 1080P	
15.	1920*1080	33.75	30.00	74.25	HDTV 1080P	
16.	1920*1080	33.71	29.97	74.176	HDTV 1080P	

• HDMI Monitor Range Limits

Min Vertical Freq - 56 Hz

Min Horiz. Freq - 30 kHz

Pixel Clock - 170 MHz

Max Vertical Freq - 62 Hz

Max Horiz. Freq - 80 kHz

# ADJUSTMENT INSTRUCTION

## 1. Application Range

This specification sheet is applied all of the LJ03D/E LCD TV models, which produced in manufacture department or similar LG TV factory

## 2. Notice

- (1) Because this is not a hot chassis, it is not necessary to use an isolation transformer. However, the use of isolation transformer will help protect test instrument.
- (2) Adjustment must be done in the correct order.
- (3) The adjustment must be performed in the circumstance of  $25\text{ }^{\circ}\text{C} \pm 5\text{ }^{\circ}\text{C}$  of temperature and  $65\% \pm 10\%$  of relative humidity if there is no specific designation.
- (4) The input voltage of the receiver must keep AC 100-220 V~ 50 / 60Hz.
- (5) Before adjustment, execute Heat-Run for 5 minutes.

△ After Receive 100% Full white pattern (06CH) then process Heat-run

(or "8. Test pattern" condition of Ez-Adjust status)

△ How to make set white pattern

- 1) Press Power ON button of Service Remocon
- 2) Press ADJ button of Service remocon. Select "8. Test pattern" and, after select "White" using navigation button, and then you can see 100% Full White pattern.

\* In this status you can maintain Heat-Run useless any pattern generator

\* **Notice:** if you maintain one picture over 20 minutes (Especially sharp distinction black with white pattern – 13Ch, or Cross hatch pattern – 09Ch) then it can appear image stick near black level.

## 3. Adjustment Items

### 3.1. PCB Assembly Adjustment

- △ MAC Address Download
- △ Adjust 480i Comp1
- △ Adjust 1080p Comp1/RGB
  - If it is necessary, it can adjustment at Manufacture Line
  - You can see set adjustment status at "1. ADJUST CHECK" of the "In-start menu"
- △ EDID (The Extended Display Identification Data)/DDC (Display Data Channel) download

### 3.2. Set Assembly Adjustment

- △ Color Temperature (White Balance) Adjustment
- △ Using RS-232C
- △ PING Test
- △ Selection Factory output option

## 4. PCB Assembly Adjustment

### 4.1. MAC Address

#### 4.1.1. Equipment & Condition

- Play file: Serial.exe
- MAC Address edit
- Input Start / End MAC address

#### 4.1.2 Download method

##### 4.1.2.1 Communication Prot connection

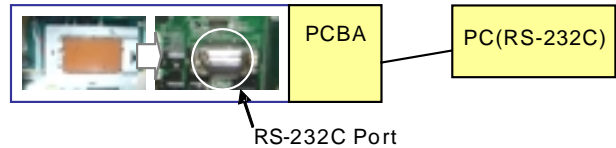

Connect: PCBA Jig-> RS-232C Port== PC-> RS-232C Port

##### 4.1.2.2 MAC Address Download

- Com 1,2,3,4 and 115200(Baudrate)
- Port connection button click(1)

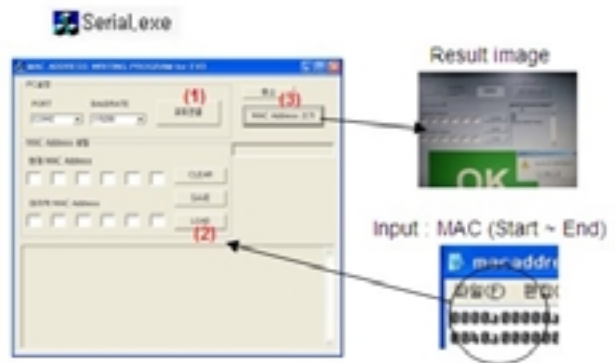

- Load button click(2) for MAC Address write.
- Start MAC Address write button(3)
- Check the OK Or NG

#### 4.1.3 Equipment & Condition

- Each other connection to LAN Port of IP Hub and Jig





## 5 Factory Adjustment

### 5.1 Manual Adjust Component 480i/1080p RGB 1080p

A Summary : Adjustment component 480i/1080i and RGB 1080p is Gain and Black level setting at Analog to Digital converter, and compensate the RGB deviation

A Using instrument

- Adjustment remocon, 801GF(802B, 802F, 802R) or MSPG925FA pattern generator (It can output 480i/1080i horizontal 100% color bar pattern signal, and its output level must setting 0.7V±0.1V p-p correctly)

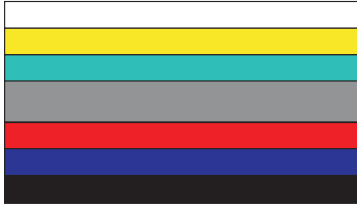

<Pic.4 Adjustment pattern : 480i / 1080p 60Hz Pattern >

A You must make it sure its resolution and pattern cause every instrument can have different setting

A Adjustment method 480i Comp1, Adjust 1080p Comp1/RGB (Factory adjustment)

- ADC 480i Component1 adjustment
  - Check connection of Component1
  - MSPG-925FA -> Model: 209, Pattern 65
- Set Component 480i mode and 100% Horizontal Color Bar Pattern(HozTV31Bar), then set TV set to Component1 mode and its screen to "NORMAL"
- ADC 1080p Component1 / RGB adjustment
  - Check connection both of Component1 and RGB
  - MSPG-925FA -> Model: 225, Pattern 65
- Set Component 1080p mode and 100% Horizontal Color Bar Pattern(HozTV31Bar), then set TV set to Component1 mode and its screen to "NORMAL"
- After get each the signal, wait more a second and enter the "IN-START" with press IN-START key of Service remocon. After then select "7. External ADC" with navigator button and press "Enter".
- After Then Press key of Service remocon "Right Arrow(VOL+)"
- You can see "ADC Component1 Success"
- Component1 1080p, RGB 1080p Adjust is same method.
- Component 1080p Adjustment in Component1 input mode
- RGB 1080p adjustment in RGB input mode
- If you success RGB 1080p Adjust. You can see "ADC RGB-DTV Success"

### 5.2 EDID (The Extended Display Identification Data) / DDC (Display Data Channel) Download.

A Summary

- It is established in VESA, for communication between PC and Monitor without order from user for building user condition. It helps to make easily use realize "Plug and Play" function.

- For EDID data write, we use DDC2B protocol.

A Auto Download

- After enter Service Mode by pushing "ADJ" key,
- Enter EDID D/L mode.
- Enter "START" by pushing "OK" key.

=> Caution : - Never connect HDMI & D-sub Cable when the user downloading .

- Use the proper cables below for EDID Writing.



§ Edid data and Model option download (RS232)

NO	Item	CMD 1	CMD 2	DATA 1	DATA 2	Notes
1	Enter download MODE	A	E	0	0	When transfer the "Mode In", Carry the command.
2	Edid data and Model option download	A	E	*Note1	*Note2	Automatically download (The use of a internal Data)
3	Adjust "Mode Out"	A	E	9	0	
4	Adjustment Confirmation	A	E	9	9	To check Download in Assembly line.

### 5.2.1 Manual Download

#### A Write HDMI EDID data

- Using instruments
  - Jig. (PC Serial to D-Sub connection) for PC, DDC adjustment.
  - S/W for DDC recording (EDID data write and read)
  - D-sub jack
  - Additional HDMI cable connection Jig.
- Preparing and setting.
  - Set instruments and Jig. Like pic.5), then turn on PC and Jig.
  - Operate DDC write S/W (EDID write & read)
  - It will operate in the DOS mode.

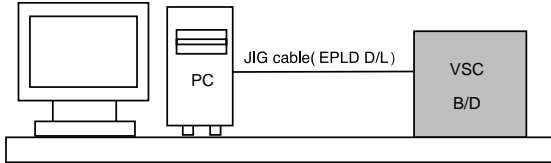

Pic.3) For write EDID data, setting Jig and another instruments.

- EDID data for LJ03B/D/E/R Chassis (Model name = LG TV)
  - HDMI-1 EDID table (0x04, 0x5A)

Addr	00	01	02	03	04	05	06	07	08	09	0A	0B	0C	0D	0E	0F
0000	00	FF	FF	FF	FF	FF	FF	00	1E	6D	01	00	01	01	01	01
0010	01	14	01	03	80	10	09	78	0A	EE	91	A3	54	4C	99	26
0020	0F	50	54	A1	08	00	81	80	61	40	45	40	31	40	01	01
0030	01	01	01	01	01	01	02	3A	80	18	71	38	2D	40	58	2C
0040	45	00	A0	5A	00	00	00	1E	01	1D	00	72	51	D0	1E	20
0050	6E	28	55	00	A0	5A	00	00	00	1E	00	00	00	FD	00	39
0060	3F	1F	52	10	00	0A	20	20	20	20	20	20	20	00	00	FC
0070	00	4C	47	20	54	56	0A	20	20	20	20	20	20	20	01	04
0080	02	03	1F	F1	47	10	22	20	05	84	03	02	24	15	07	50
0090	09	07	07	67	03	0C	00	10	00	B8	2D	E3	05	03	01	02
00A0	3A	80	18	71	38	2D	40	58	2C	04	05	A0	5A	00	00	00
00B0	1E	01	1D	80	18	71	1C	16	20	58	2C	25	00	A0	5A	00
00C0	00	00	9E	01	1D	00	72	51	D0	1E	20	6E	28	55	00	A0
00D0	5A	00	00	00	1E	0C	0A	D0	8A	20	E0	2D	10	10	3E	96
00E0	00	A0	5A	00	00	00	18	26	36	80	A0	70	38	1F	40	30
00F0	20	25	00	A0	5A	00	00	00	1A	00	00	00	00	00	00	5A

- HDMI-2 EDID table (0x04, 0x4A)

Addr	00	01	02	03	04	05	06	07	08	09	0A	0B	0C	0D	0E	0F
0000	00	FF	FF	FF	FF	FF	FF	00	1E	6D	01	00	01	01	01	01
0010	01	14	01	03	80	10	09	78	0A	EE	91	A3	54	4C	99	26
0020	0F	50	54	A1	08	00	81	80	61	40	45	40	31	40	01	01
0030	01	01	01	01	01	01	02	3A	80	18	71	38	2D	40	58	2C
0040	45	00	A0	5A	00	00	00	1E	01	1D	00	72	51	D0	1E	20
0050	6E	28	55	00	A0	5A	00	00	00	1E	00	00	00	FD	00	39
0060	3F	1F	52	10	00	0A	20	20	20	20	20	20	20	00	00	FC
0070	00	4C	47	20	54	56	0A	20	20	20	20	20	20	20	01	04
0080	02	03	1F	F1	47	10	22	20	05	84	03	02	24	15	07	50
0090	09	07	07	67	03	0C	00	20	00	B8	2D	E3	05	03	01	02
00A0	3A	80	18	71	38	2D	40	58	2C	04	05	A0	5A	00	00	00
00B0	1E	01	1D	80	18	71	1C	16	20	58	2C	25	00	A0	5A	00
00C0	00	00	9E	01	1D	00	72	51	D0	1E	20	6E	28	55	00	A0
00D0	5A	00	00	00	1E	0C	0A	D0	8A	20	E0	2D	10	10	3E	96
00E0	00	A0	5A	00	00	00	18	26	36	80	A0	70	38	1F	40	30
00F0	20	25	00	A0	5A	00	00	00	1A	00	00	00	00	00	00	4A

- HDMI-3 EDID table (0x04, 0x3A)

Addr	00	01	02	03	04	05	06	07	08	09	0A	0B	0C	0D	0E	0F
0000	00	FF	FF	FF	FF	FF	FF	00	1E	6D	01	00	01	01	01	01
0010	01	14	01	03	80	10	09	78	0A	EE	91	A3	54	4C	99	26
0020	0F	50	54	A1	08	00	81	80	61	40	45	40	31	40	01	01
0030	01	01	01	01	01	01	02	3A	80	18	71	38	2D	40	58	2C
0040	45	00	A0	5A	00	00	00	1E	01	1D	00	72	51	D0	1E	20
0050	6E	28	55	00	A0	5A	00	00	00	1E	00	00	00	FD	00	39
0060	3F	1F	52	10	00	0A	20	20	20	20	20	20	20	00	00	FC
0070	00	4C	47	20	54	56	0A	20	20	20	20	20	20	20	01	04
0080	02	03	1F	F1	47	10	22	20	05	84	03	02	24	15	07	50
0090	09	07	07	67	03	0C	00	30	00	B8	2D	E3	05	03	01	02
00A0	3A	80	18	71	38	2D	40	58	2C	04	05	A0	5A	00	00	00
00B0	1E	01	1D	80	18	71	1C	16	20	58	2C	25	00	A0	5A	00
00C0	00	00	9E	01	1D	00	72	51	D0	1E	20	6E	28	55	00	A0
00D0	5A	00	00	00	1E	0C	0A	D0	8A	20	E0	2D	10	10	3E	96
00E0	00	A0	5A	00	00	00	18	26	36	80	A0	70	38	1F	40	30
00F0	20	25	00	A0	5A	00	00	00	1A	00	00	00	00	00	00	3A

- HDMI-4 EDID table (0x04, 0x2A)

Addr	00	01	02	03	04	05	06	07	08	09	0A	0B	0C	0D	0E	0F
0000	00	FF	FF	FF	FF	FF	FF	00	1E	6D	01	00	01	01	01	01
0010	01	14	01	03	80	10	09	78	0A	EE	91	A3	54	4C	99	26
0020	0F	50	54	A1	08	00	81	80	61	40	45	40	31	40	01	01
0030	01	01	01	01	01	01	02	3A	80	18	71	38	2D	40	58	2C
0040	45	00	A0	5A	00	00	00	1E	01	1D	00	72	51	D0	1E	20
0050	6E	28	55	00	A0	5A	00	00	00	1E	00	00	00	FD	00	39
0060	3F	1F	52	10	00	0A	20	20	20	20	20	20	20	00	00	FC
0070	00	4C	47	20	54	56	0A	20	20	20	20	20	20	20	01	04
0080	02	03	1F	F1	47	10	22	20	05	84	03	02	24	15	07	50
0090	09	07	07	67	03	0C	00	40	00	B8	2D	E3	05	03	01	02
00A0	3A	80	18	71	38	2D	40	58	2C	04	05	A0	5A	00	00	00
00B0	1E	01	1D	80	18	71	1C	16	20	58	2C	25	00	A0	5A	00
00C0	00	00	9E	01	1D	00	72	51	D0	1E	20	6E	28	55	00	A0
00D0	5A	00	00	00	1E	0C	0A	D0	8A	20	E0	2D	10	10	3E	96
00E0	00	A0	5A	00	00	00	18	26	36	80	A0	70	38	1F	40	30
00F0	20	25	00	A0	5A	00	00	00	1A	00	00	00	00	00	00	2A

- Analog (RGB) EDID table (0x1D)

Addr	00	01	02	03	04	05	06	07	08	09	0A	0B	0C	0D	0E	0F
0000	00	FF	FF	FF	FF	FF	FF	00	1E	6D	01	00	01	01	01	01
0010	01	14	01	03	80	10	09	78	0A	EE	91	A3	54	4C	99	26
0020	0F	50	54	A1	08	00	81	80	61	40	45	40	31	40	01	01
0030	01	01	01	01	01	01	02	3A	80	18	71	38	2D	40	58	2C
0040	45	00	A0	5A	00	00	00	1E	01	1D	00	72	51	D0	1E	20
0050	6E	28	55	00	A0	5A	00	00	00	1E	00	00	00	FD	00	3A
0060	3E	1E	53	10	00	0A	20	20	20	20	20	20	20	00	00	FC
0070	00	4C	47	20	54	56	0A	20	20	20	20	20	20	20	00	1D
0080	FF	FF	FF	FF	FF	FF	FF	FF	FF	FF	FF	FF	FF	FF	FF	FF
0090	FF	FF	FF	FF	FF	FF	FF	FF	FF	FF	FF	FF	FF	FF	FF	FF
00A0	FF	FF	FF	FF	FF	FF	FF	FF	FF	FF	FF	FF	FF	FF	FF	FF
00B0	FF	FF	FF	FF	FF	FF	FF	FF	FF	FF	FF	FF	FF	FF	FF	FF
00C0	FF	FF	FF	FF	FF	FF	FF	FF	FF	FF	FF	FF	FF	FF	FF	FF
00D0	FF	FF	FF	FF	FF	FF	FF	FF	FF	FF	FF	FF	FF	FF	FF	FF
00E0	FF	FF	FF	FF	FF	FF	FF	FF	FF	FF	FF	FF	FF	FF	FF	FF
00F0	FF	FF	FF	FF	FF	FF	FF	FF	FF	FF	FF	FF	FF	FF	FF	FF

See Working Guide if you want more information about EDID communication.

## 5.3 Adjustment Color Temperature (White balance)

### A Using Instruments

- Color Analyzer: CA-210 (CH 9)
  - Using LCD color temperature, Color Analyzer (CA-210) must use CH 9, which Matrix compensated (White, Red, Green, Blue compensation) with CS-2100. See the Coordination bellowed one.
- Auto-adjustment Equipment (It needs when Auto-adjustment – It is availed communicate with RS-232C : Baud rate: 115200)
- Video Signal Generator MSPG-925F 720p, 216Gray (Model: 217, Pattern 78)

### A Connection Diagram (Auto Adjustment)

- Using Inner Pattern

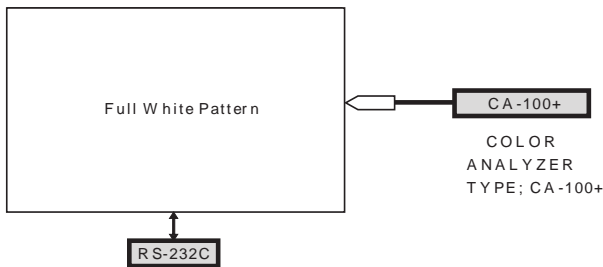

- Using HDMI input

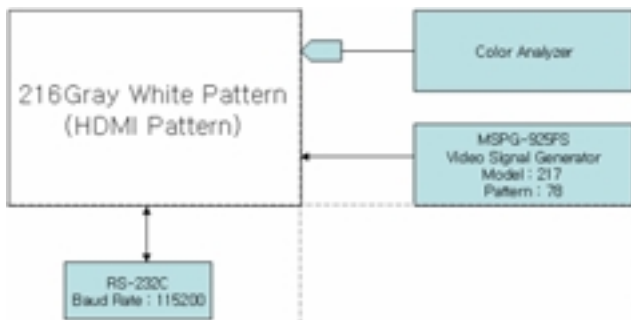

<Pic.5 Connection Diagram for Adjustment White balance>

### A White Balance Adjustment

If you can't adjust with inner pattern, then you can adjust it using HDMI pattern. You can select option at "Ez-Adjust Menu – 7. White Balance" there items "NONE, INNER, HDMI". It is normally setting at inner basically. If you can't adjust using inner pattern you can select HDMI item, and you can adjust.

In manual Adjust case, if you press ADJ button of service remoon, and enter "Ez-Adjust Menu – 7. White Balance", then automatically inner pattern operates. (In case of "Inner" originally "Test-Pattern. On" will be selected in The "Test-Pattern. On/Off".

- Connect all cables and equipments like Pic.5)
- Set Baud Rate of RS-232C to 115200. It may set 115200 originally.
- Connect RS-232C cable to set
- Connect HDMI cable to set



### A RS-232C Command (Commonly apply)

RS-232C COMMAND			Meaning
[CMD]	ID	D	
wb	00	00	White Balance adjustment start.
wb	00	10	Start of adjust gain (Inner white pattern)
wb	00	1f	End of gain adjust
wb	00	20	Start of offset adjust(inner white pattern)
wb	00	2f	End of offset adjust
wb	00	ff	End of White Balance adjust(inner pattern disappeared)

- "wb 00 00": Start Auto-adjustment of white balance.
- "wb 00 10": Start Gain Adjustment (Inner pattern)
- "jb 00 c0" :
- ...
- "wb 00 1f": End of Adjustment
  - \* If it needs, offset adjustment (wb 00 20-start, wb 00 2f-end)
- "wb 00 ff": End of white balance adjustment (inner pattern disappear)

**○ Notice) Adjustment Mapping information**

	RS-232C COMMAND [CMD ID Data]			MIN	CENTER (DEFAULT)			MAX
	Cool	Mid	Warm		Cool	Mid	Warm	
R Gain	9g	9a	9d	00	192	192	192	192
G Gain	9h	9b	9e	00	189	175	157	192
B Gain	9i	9c	9f	00	153	127	97	192
R Cut					64	64	64	127
G Cut					64	64	64	127

- When Color temperature (White balance) Adjustment (Automatically)
  - Press "Power only key" of service remocon and operate automatically adjustment.
  - Set BaudRate to 115200.
- If it needs, then adjustment "Offset".

**A White Balance Adjustment (Manual adjustment)**

- Test Equipment: CA-210
  - Using LCD color temperature, Color Analyzer (CA-210) must use CH 9, which Matrix compensated (White, Red, Green, Blue compensation) with CS-2100. See the Coordination bellowed one.
- Manual adjustment sequence is like bellowed one.
  - Turn to "Ez-Adjust" mode with press ADJ button of service remocon.
  - Select "10.Test Pattern" with CH+/- button and press enter. Then set will go on Heat-run mode. Over 30 minutes set let on Heat-run mode.
  - Let CA-210 to zero calibration and must has gap more 10cm from center of LCD module when adjustment.
  - Press "ADJ" button of service remocon and select "7.White-Balance" in "Ez-Adjust" then press " G " button of navigation key.  
(When press " G " button then set will go to full white mode)
  - Adjust at three mode (Cool, Medium, Warm)
    - If "cool" mode  
Let B-Gain to 192 and R, G, B-Cut to 64 and then control R, G gain adjustment High Light adjustment.
    - If "Medium" and "Warm" mode  
Let R-Gain to 192 and R, G, B-Cut to 64 and then control G, B gain adjustment High Light adjustment.
    - All of the three mode  
Let R-Gain to 192 and R, G, B-Cut to 64 and then control G, B gain adjustment High Light adjustment.
  - With volume button (+/-) you can adjust.
  - After all adjustment finished, with Enter (A key) turn to Ez-Adjust mode. Then with ADJ button, exit from adjustment mode

Attachment: White Balance adjustment coordination and color temperature.

- Using CS-1000 Equipment.
  - COOL : T=11000K,  $\Delta uv=0.000$ ,  $x=0.276$   $y=0.283$
  - MEDIUM : T=9300K,  $\Delta uv=0.000$ ,  $x=0.285$   $y=0.293$
  - WARM : T=6500K,  $\Delta uv=0.000$ ,  $x=0.313$   $y=0.329$

- Using CA-210 Equipment. (9 CH)
  - Contrast value: 216 Gray

Color temperature	Test Equipment	Color Coordination	
		X	Y
COOL	CA-210	0.269±0.002	0.273±0.002
MEDIUM	CA-210	0.285±0.002	0.293±0.002
WARM	CA-210	0.313±0.002	0.329±0.002

- White Balance adjustment coordination and color temperature for Edge(IOP) LED (LJ03D/E)

Color Temperature	Cool	13,000K	%	X=0.269 (±0.002) Y=0.273 (±0.002)	32A2/47.55LE7500-SA 32A2/47.55LE5500-SA 43LE8500-SA	<Test Signal> Inner pattern (216gray,85RE)
	Medium	9,300K	%	X=0.285 (±0.002) Y=0.293 (±0.002)		
	Warm	6,500K	%	X=0.313 (±0.002) Y=0.329 (±0.002)		

- White Balance adjustment table for Edge (IOP) LED (LJ03D/E)

	H/R Time(Min)	Cool		Medium		Warm	
		x	y	x	y	x	y
		269	273	285	293	313	329
1	0-2 Min	280	291	296	311	319	340
2	3-5 Min	278	288	294	308	317	338
3	6-9 Min	276	285	292	305	315	335
4	10-19 Min	274	282	290	302	313	332
5	20-35 Min	273	279	289	299	312	329
6	36-49 Min	270	276	287	296	310	326
7	50-79 Min	269	273	286	293	308	323
8	Above of 80 Min	269	273	285	293	308	323

## 5.4 EYE-Q function check

- 1) Turn on TV
- 2) Press EYE key of Adj. R/C
- 3) Cover the Eye Q II sensor on the front of the using your hand and wait for 6 seconds
- 4) Confirm that R/G/B value is lower than 10 of the "Raw Data (Sensor data, Back light)". If after 6 seconds, R/G/B value is not lower than 10, replace Eye Q II sensor
- 5) Remove your hand from the Eye Q II sensor and wait for 6 seconds
- 6) Confirm that "ok" pop up.  
If change is not seen, replace Eye Q II sensor

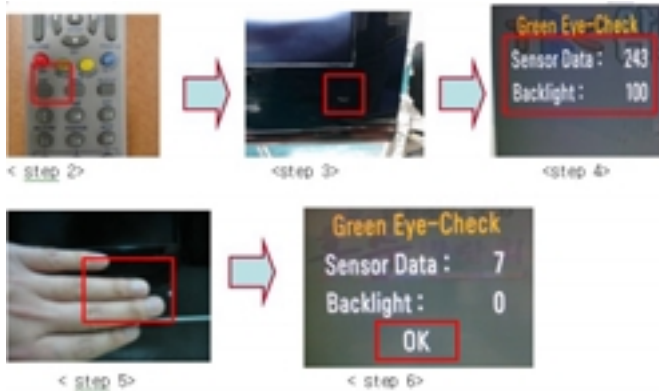

## 5.5 HDCP (High-Bandwidth Digital Contents Protection) Setting

- No Need.

## 5.6 Test of RS-232C control.

Press In-Start button of Service Remocon then set the "4.Baud Rate" to 115200. Then check RS-232C control and

## 5.7 Selection of Country option.

Selection of country option is allowed only North American model (Not allowed Korean model). It is selection of Country about Rating and Time Zone.

- Models: All models which use LJ03X Chassis (See the first page.)
- Press "In-Start" button of Service Remocon, then enter the "Option" Menu with "PIP CH-" Button
- Select one of these three (USA, CANADA, MEXICO) depends on its market using "Vol. +/-" button.

**\* Caution : Don't push The INSTOP KEY after completing the function inspection.**

## 6. GND and ESD Testing

### 6.1 Prepare GND and ESD Testing.

- A Check the connection between set and power cord

### 6.2 Operate GND and ESD auto-test.

- A Fully connected (Between set and power cord) set enter the Auto-test sequence.
- A Connect D-Jack AV jack test equipment.
- A Turn on Auto-controller(GWS103-4)
- A Start Auto GND test.
- A If its result is NG, then notice with buzzer.
- A If its result is OK, then automatically it turns to ESD Test.
- A Operate ESD test
- A If its result is NG, then notice with buzzer.
- A If its result is OK, then process next steps. Notice it with Good lamp and STOPER Down.Check Items.
- A Test Voltage
  - GND: 1.5KV/min at 100mA
  - Signal: 3KV/min at 100mA
- A Test time: just 1 second.
- A Test point
  - GND test: Test between Power cord GND and Signal cable metal GND.
  - ESD test: Test between Power cord GND and Live and neutral.
- A Leakage current: Set to 0.5mA(rms)

## 7. Preset Ch information.

Factory	SYSTEM	CH	F FREQ	S FREQ	VIDEO	AUDIO	REMARK
KOREA	NTSC	US-2	56.25	59.75	SMITE	STEREOT SAP	
	PALM	BR-4	67.25	71.75	DIGITAL	14Hz	
	NTSC	US-6	69.25	67.75	PRODUCTION SYSTEM	14Hz	
	NTSC	US-7	126.25	129.75	MOTION PICTURE	SWEEP	
	NTSC	US-9	167.25	191.75	CROSS MATCH	SWEEP	
	PALN	BR-11	198.25	203.75	DIGITAL	14Hz	
	NTSC	US-13	211.25	216.75	DIGITAL	STEREOT SAP	
	NTSC	US-14	471.25	476.75	RED PURITY	400Hz	
	SETVG	BR-22	F+H21 143		Broad DTV Stream		Line DTV Input Channel, TV Output Type, Layer B - 1HD
	SETVG	BR-24	F+H23 143		Broad DTV Stream		
	NTSC	US-28	568.25	569.75	CROSS MATCH	400Hz	CLOSED CAPTION
	NTSC	US-30	587.25	571.75	COLOR BAR	400Hz	Deactivated
	PALN	BR-32	579.25	583.75	COLOR BAR	14Hz	Deactivated
	NTSCM	US-69	801.25	806.75	MOTION PICTURE	MUSIC	

In case of POWER ONLY, System color is operated multi system

In case of IN STOP, System color is operated default system (PAN-M)

## 8. Default Service option.

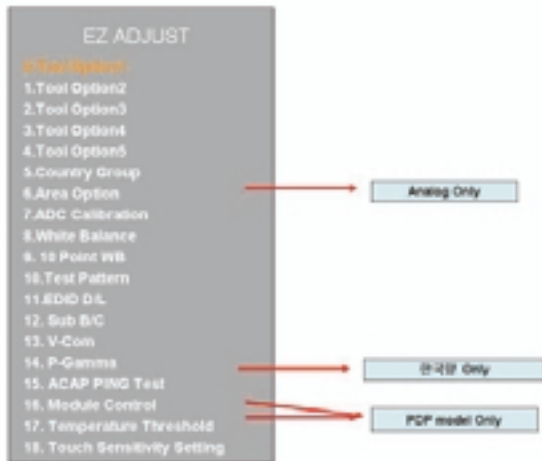

Ez ADJUST menu displays adjust menu for final setting.

### 8.1 ADC-Set.

- A R-Gain adjustment Value (default 128)
- A G-Gain adjustment Value (default 128)
- A B-Gain adjustment Value (default 128)
- A R-Offset adjustment Value (default 128)
- A G-Offset adjustment Value (default 128)
- A B-Offset adjustment Value (default 128)

### 8.2 White balance. Value.

	CENTER (DEFAULT)			MAX
	Cool	Mid	Warm	
R Gain	192	192	192	
G Gain	192	192	192	
B Gain	192	192	192	
R Cut	64	64	64	
G Cut	64	64	64	
B Cut	64	64	64	

## 9. USB DOWNLOAD (\*.epk file download)

9.1 Put the USB Stick to the USB socket

9.2 Press Menu key, and move OPTION



9.3 Press "FAV" Press 7 times.



9.4 Select download file (epk file)

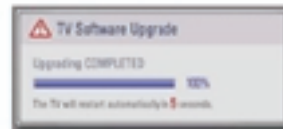
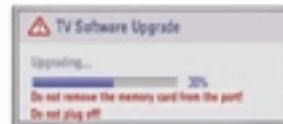

9.5 After download is finished, remove the USB stick.

9.6 Press "IN-START" key of ADJ remote control, check the S/W version.

# EXPLODED VIEW

## IMPORTANT SAFETY NOTICE

Many electrical and mechanical parts in this chassis have special safety-related characteristics. These parts are identified by  $\Delta$  in the Schematic Diagram and EXPLODED VIEW. It is essential that these special safety parts should be replaced with the same components as recommended in this manual to prevent X-RADIATION, Shock, Fire, or other Hazards. Do not modify the original design without permission of manufacturer.

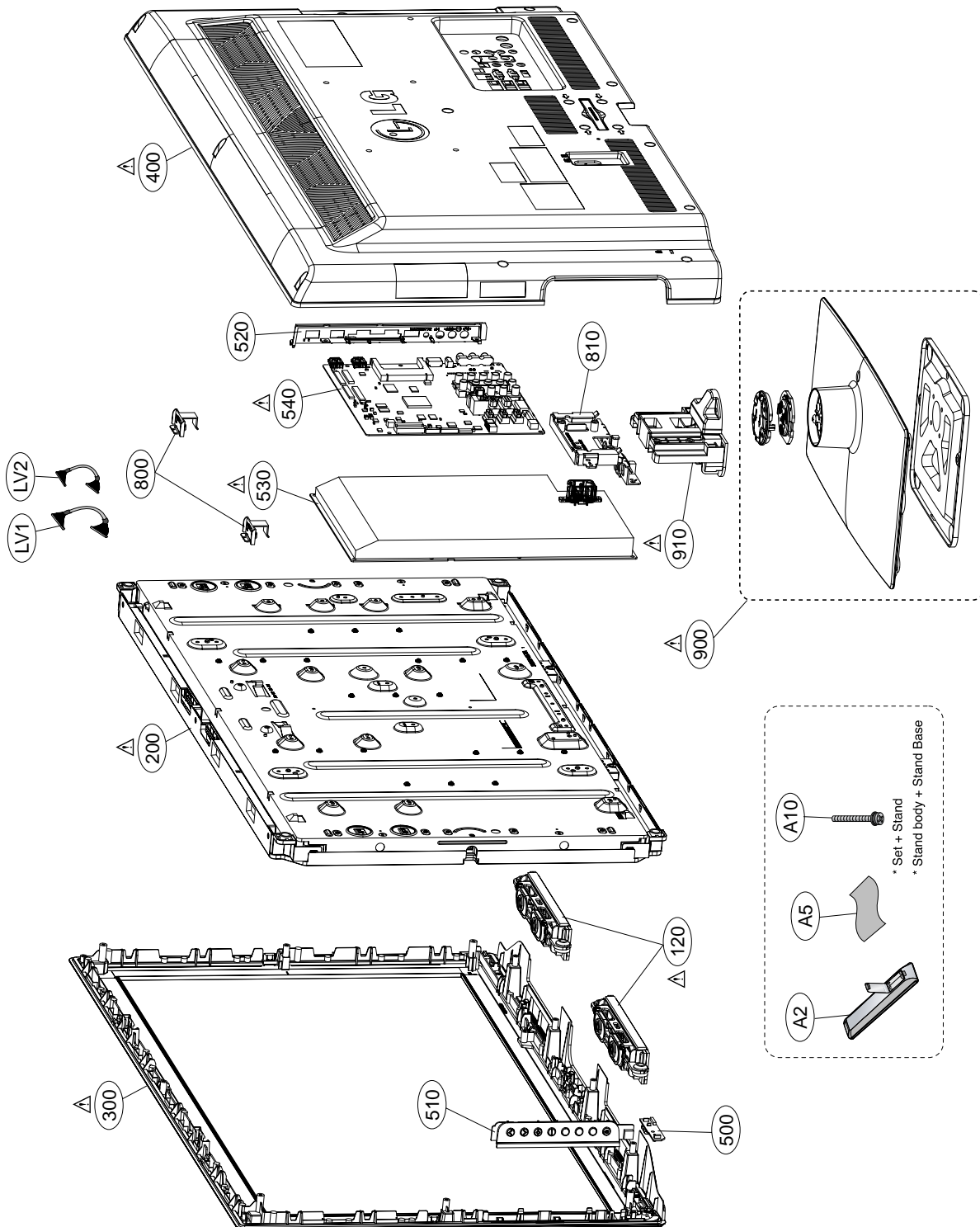

# RESET

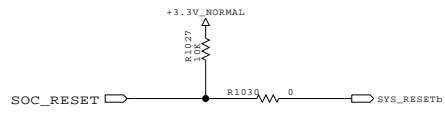

# NVRAM

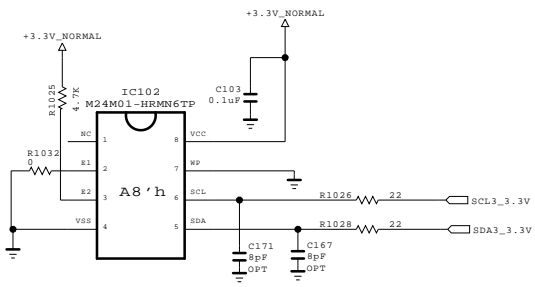

# Boot Strap

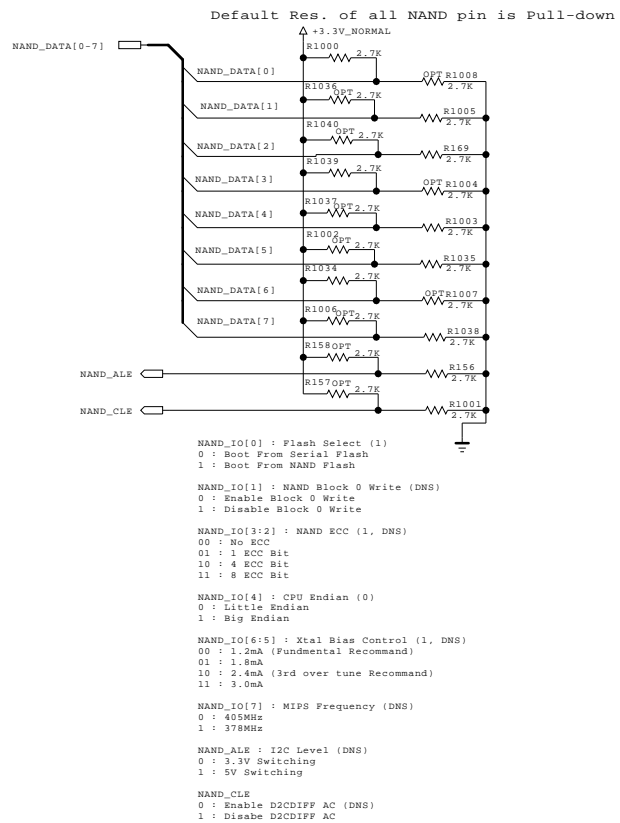

# \* NAND FLASH MEMORY 4Gbit (512M for BB)

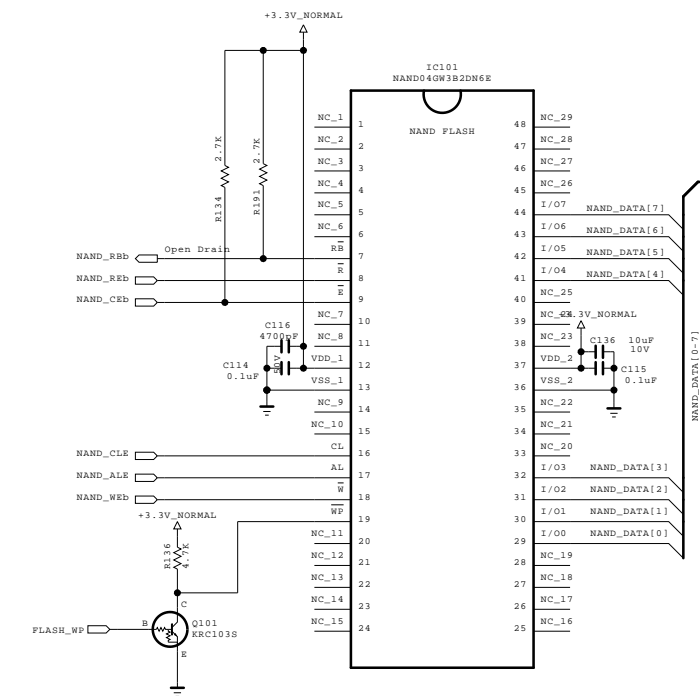

THE  $\Delta$  SYMBOL MARK OF THIS SCHEMATIC DIAGRAM INCORPORATES SPECIAL FEATURES IMPORTANT FOR PROTECTION FROM X-RADIATION. FILRE AND ELECTRICAL SHOCK HAZARDS, WHEN SERVICING IF IS ESSENTIAL THAT ONLY MANUFACTURES SPECIFIED PARTS BE USED FOR THE CRITICAL COMPONENTS IN THE  $\Delta$  SYMBOL MARK OF THE SCHEMATIC.

**SECRET**  
 LGElectronics



<b>MODEL BLOCK</b>	BCM (EUROBBTV)	<b>DATE SHEET</b>	2009.06.18
	BCM3556 & NAND FLASH		1

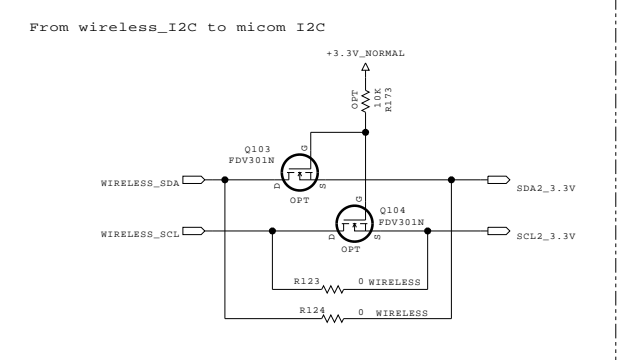
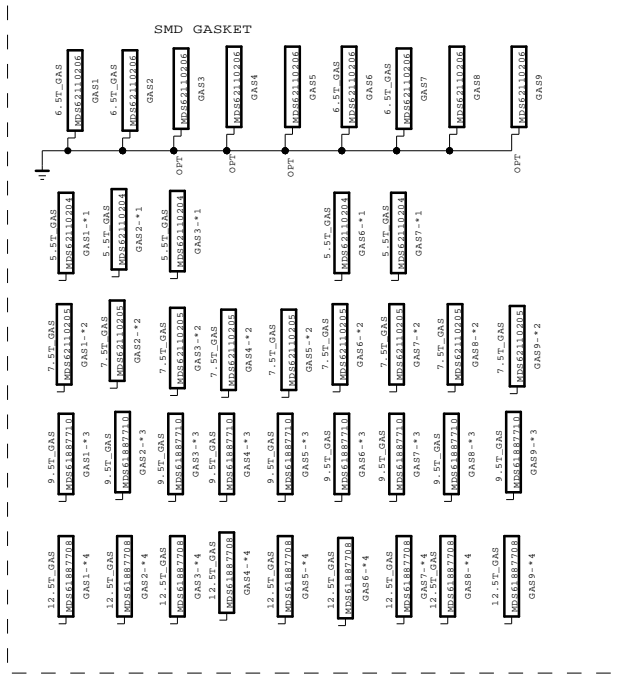

- \* I2C MAP
- \* I2C\_0 :
  - \* I2C\_1 :
  - \* I2C\_2 :
  - \* I2C\_3 :

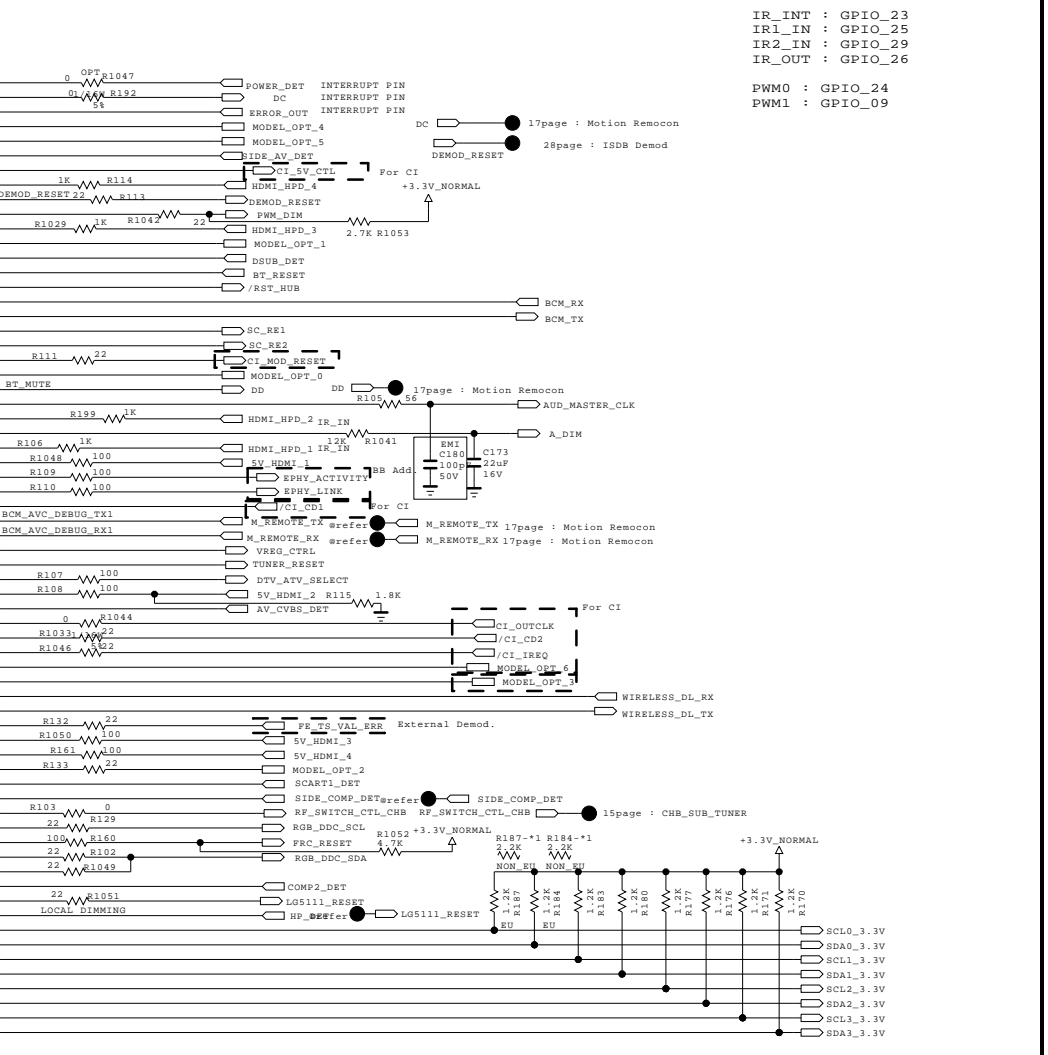
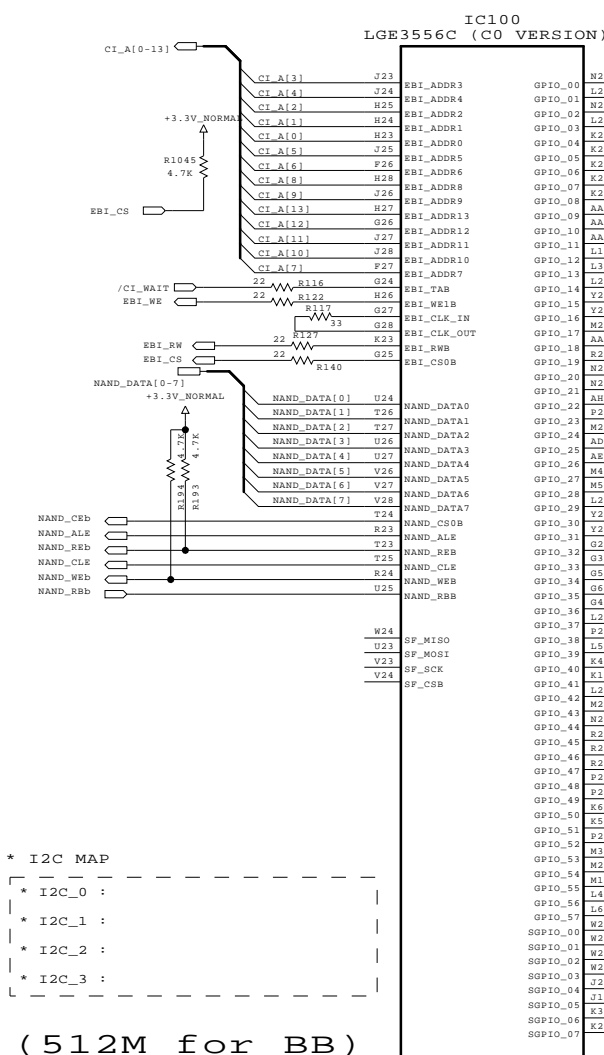

EXT\_IRQ : GPIO\_01, GPIO\_02, GPIO\_11, GPIO\_39

IR\_INT : GPIO\_23

IR1\_IN : GPIO\_25

IR2\_IN : GPIO\_29

IR\_OUT : GPIO\_26

PWM0 : GPIO\_24

PWM1 : GPIO\_09

MODEL OPTION

OPTION	PIN NAME	PIN NO.	HIGH	LOW
MODEL_OPT_0	N26	URSA3	NON_URSA3	
MODEL_OPT_1	AA28	MAIN_MINI_LVDS	MAIN_LVDS	
MODEL_OPT_2	R26	DDR-256M	DDR-512M	
MODEL_OPT_3	K1	FBD	WD	
MODEL_OPT_4	L25	FRC	NON_FRC	
MODEL_OPT_5	K27	GIP	NON-GIP	
MODEL_OPT_6	K4	OLED	NON_OLED	

\*MODEL\_OPT\_0 & MODEL\_OPT\_4 REFER TO THIS OPTION

MODEL_OPT_0	MODEL_OPT_4	NO FRC
LOW	LOW	NO FRC
HIGH	LOW	URSA3 Internal
LOW	HIGH	URSA3 External
HIGH	HIGH	PWIZ Pannel T-con with LG FRC

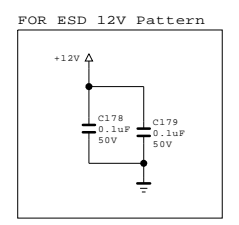



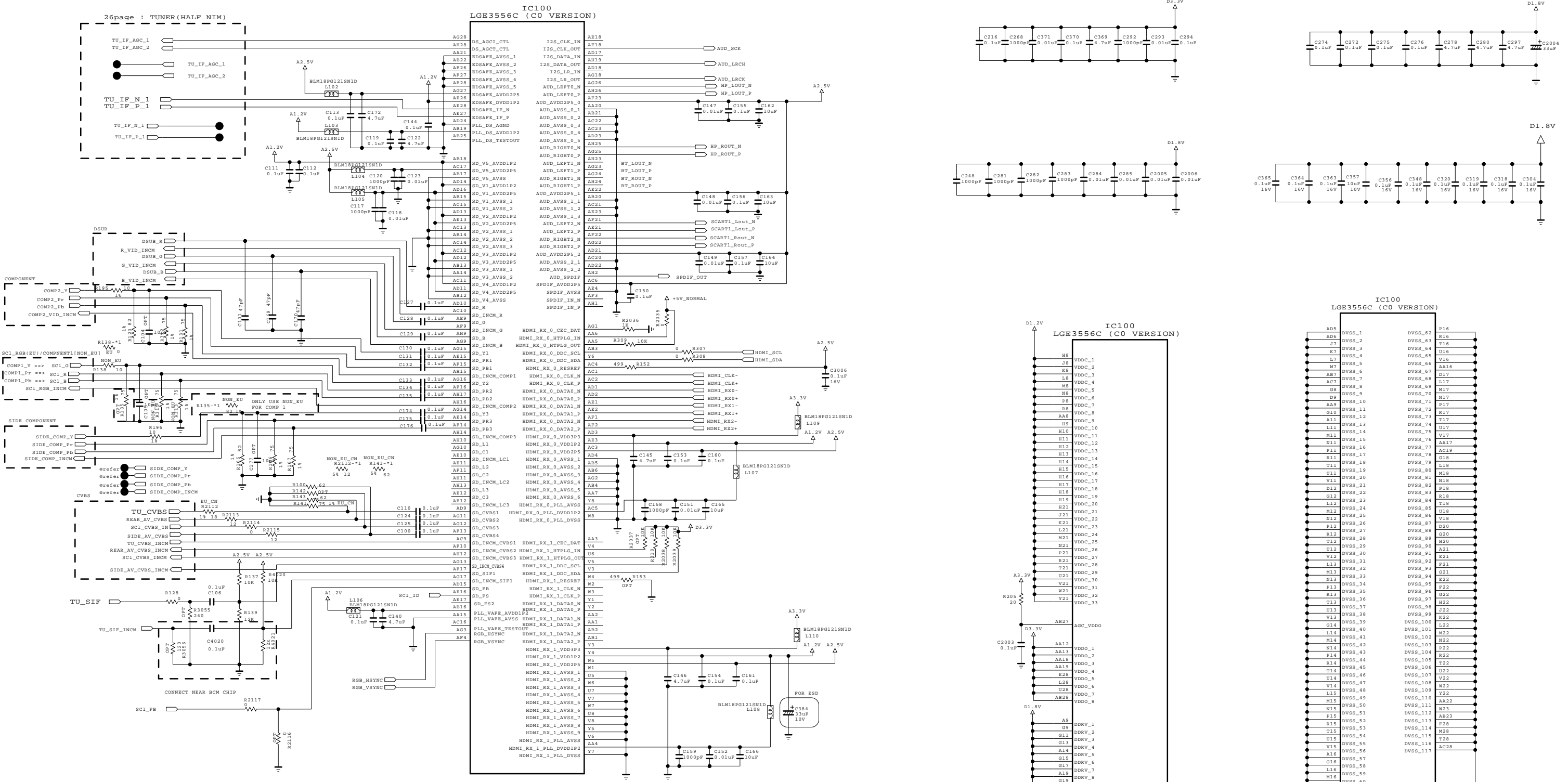
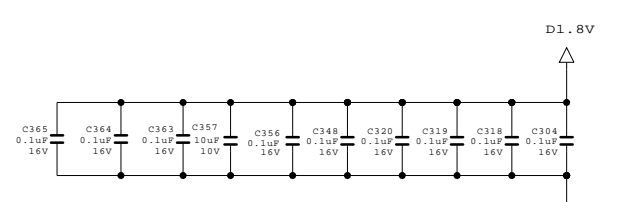
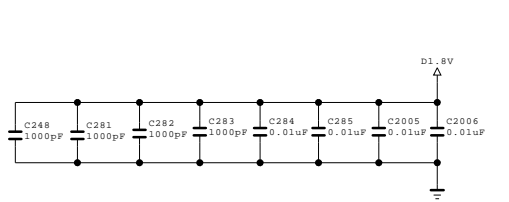
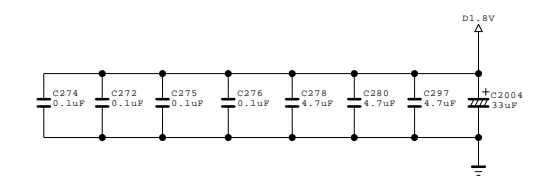
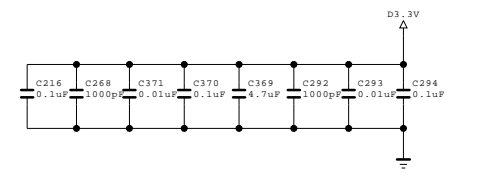
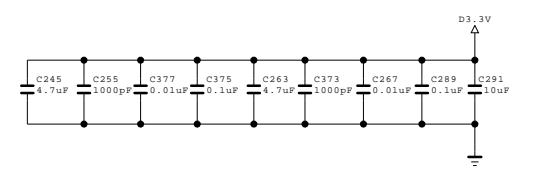
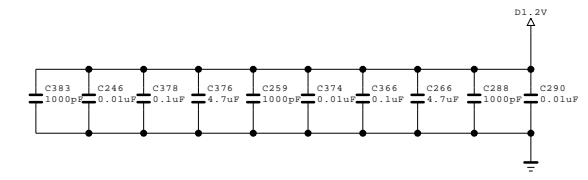
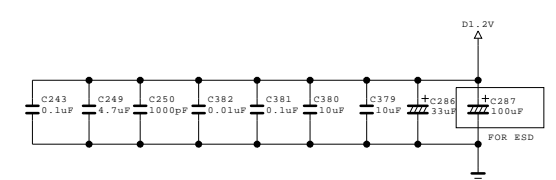
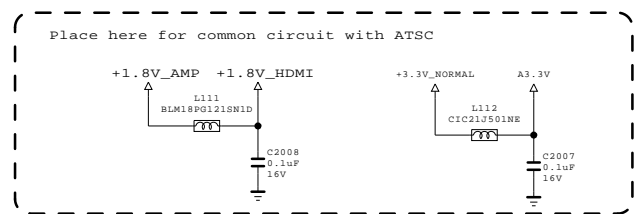

THE  $\Delta$  SYMBOL MARK OF THIS SCHEMATIC DIAGRAM INCORPORATES SPECIAL FEATURES IMPORTANT FOR PROTECTION FROM X-RADIATION. FILRE AND ELECTRICAL SHOCK HAZARDS, WHEN SERVICING IF IS ESSENTIAL THAT ONLY MANUFACTURES SPECIFIED PARTS BE USED FOR THE CRITICAL COMPONENTS IN THE  $\Delta$  SYMBOL MARK OF THE SCHEMATIC.

**SECRET**  
LGElectronics



MODEL BLOCK	EUROBBTV	DATE SHEET	2009.06.18
	BCM3556 VIDEO IN		3

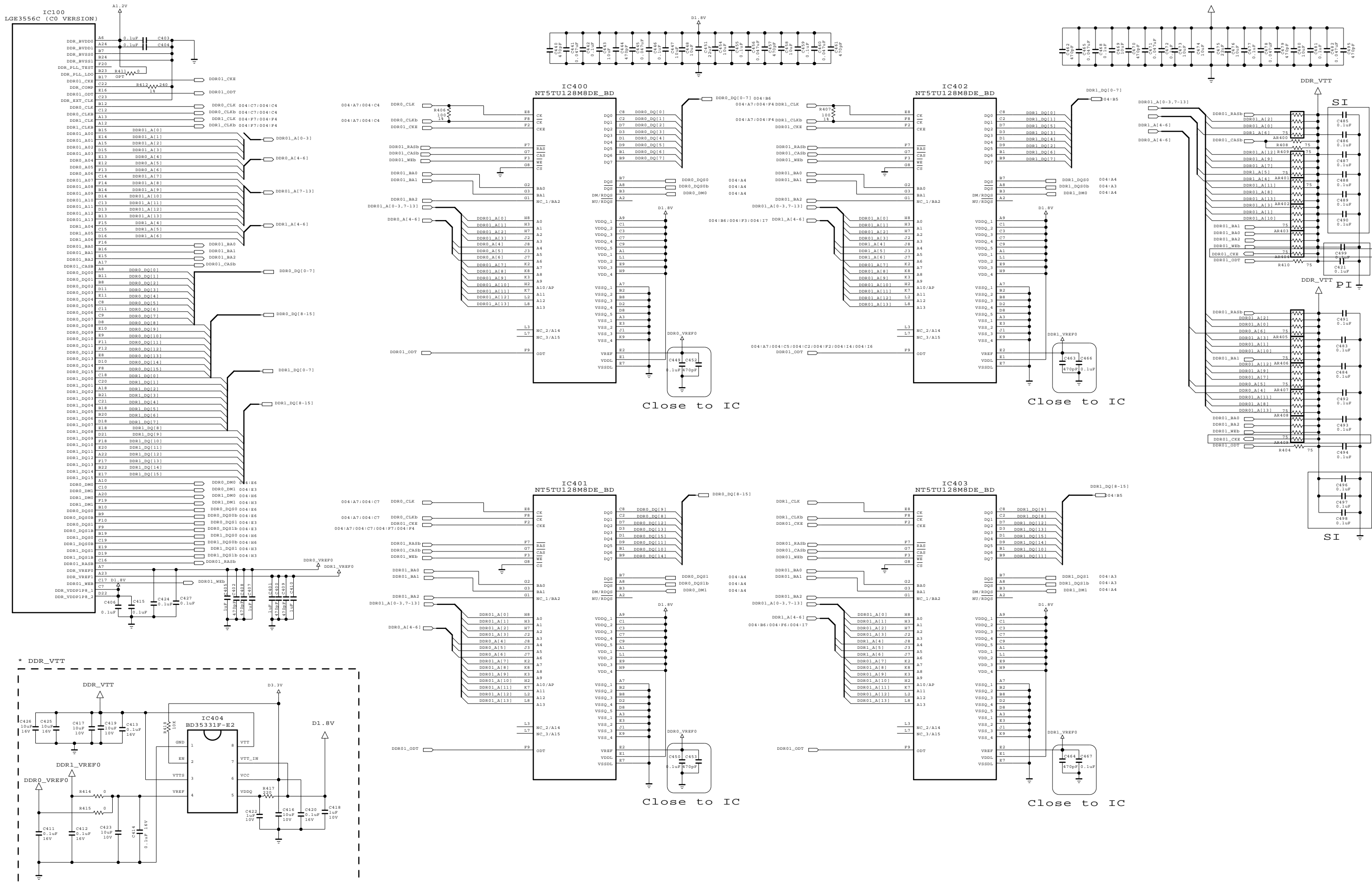

THE  $\Delta$  SYMBOL MARK OF THIS SCHEMATIC DIAGRAM INCORPORATES SPECIAL FEATURES IMPORTANT FOR PROTECTION FROM X-RADIATION. FILRE AND ELECTRICAL SHOCK HAZARDS, WHEN SERVICING IF IS ESSENTIAL THAT ONLY MANUFACTURES SPECIFIED PARTS BE USED FOR THE CRITICAL COMPONENTS IN THE  $\Delta$  SYMBOL MARK OF THE SCHEMATIC.

**SECRET**  
LGElectronics

HONG YEON HYUK



MODEL BLOCK	BCM (EUROBBTV)	DATE SHEET	2009.06.18
	DDR Memory		4

COMPONENT1  
COMPONENT2  
AV1

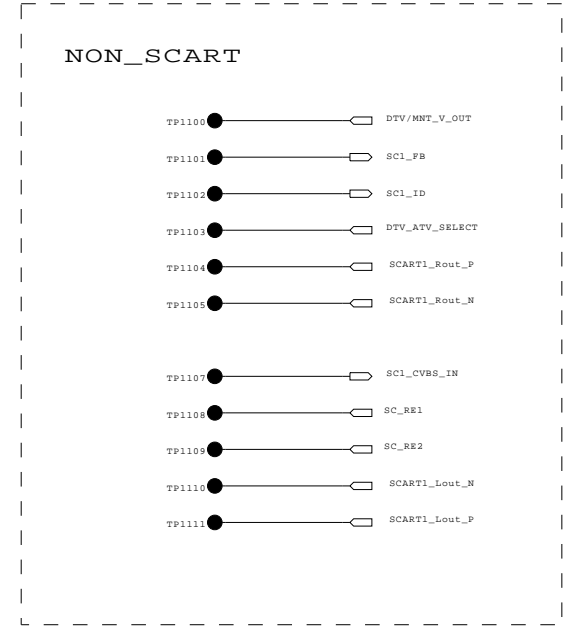
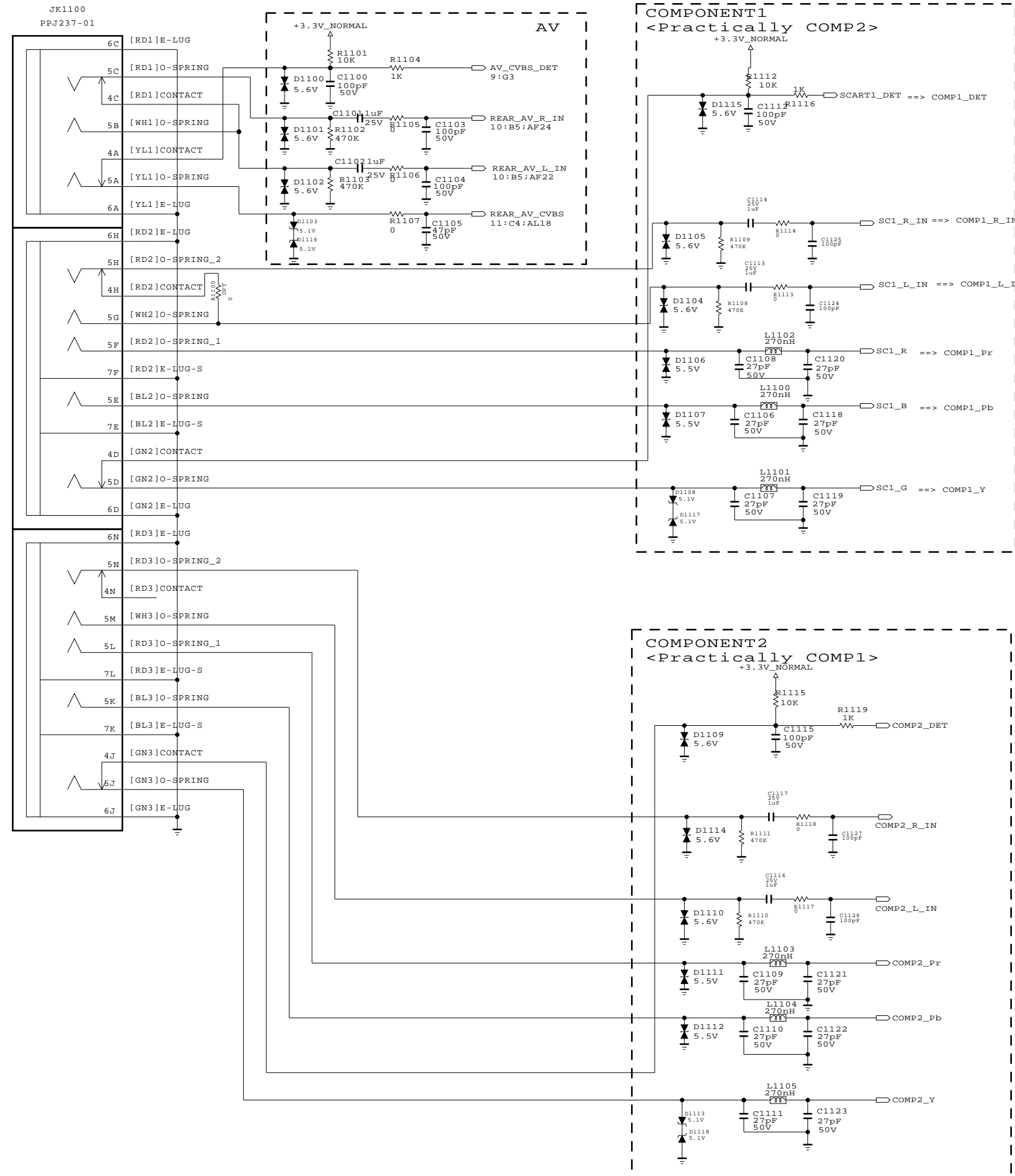

New Item Development  
EARPHONE BLOCK

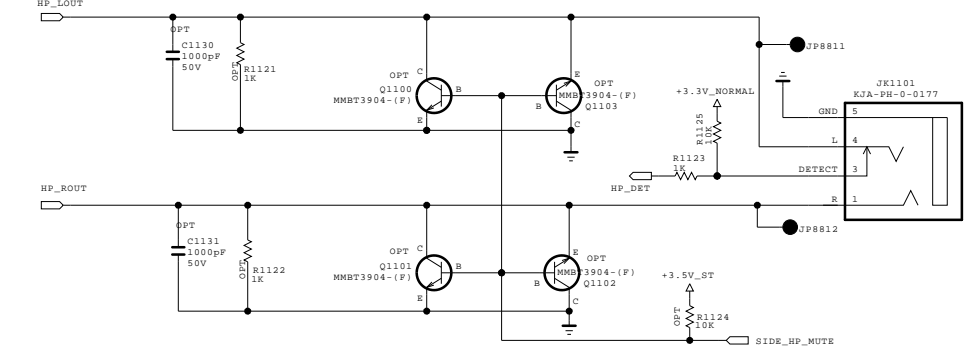

EARPHONE AMP

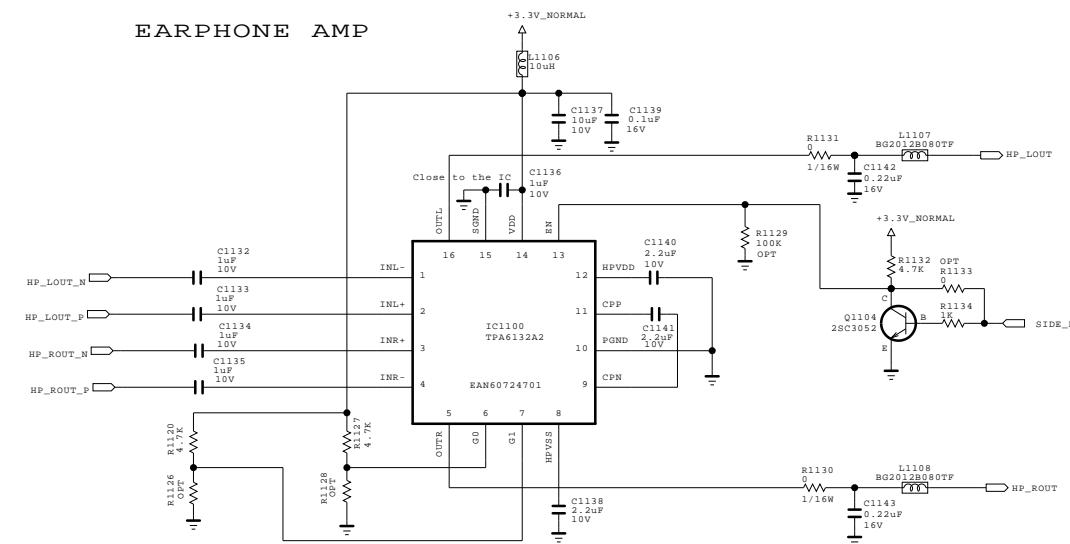

THE  $\Delta$  SYMBOL MARK OF THIS SCHEMATIC DIAGRAM INCORPORATES SPECIAL FEATURES IMPORTANT FOR PROTECTION FROM X-RADIATION. FILRE AND ELECTRICAL SHOCK HAZARDS, WHEN SERVICING IF IS ESSENTIAL THAT ONLY MANUFACTURES SPECIED PARTS BE USED FOR THE CRITICAL COMPONENTS IN THE  $\Delta$  SYMBOL MARK OF THE SCHEMATIC.

SECRET  
LGElectronics



MODEL	GP2_BCM	DATE	09/10/19
BLOCK	HP/COMP/REAR AV(NON_EU)	SHEET	11 /





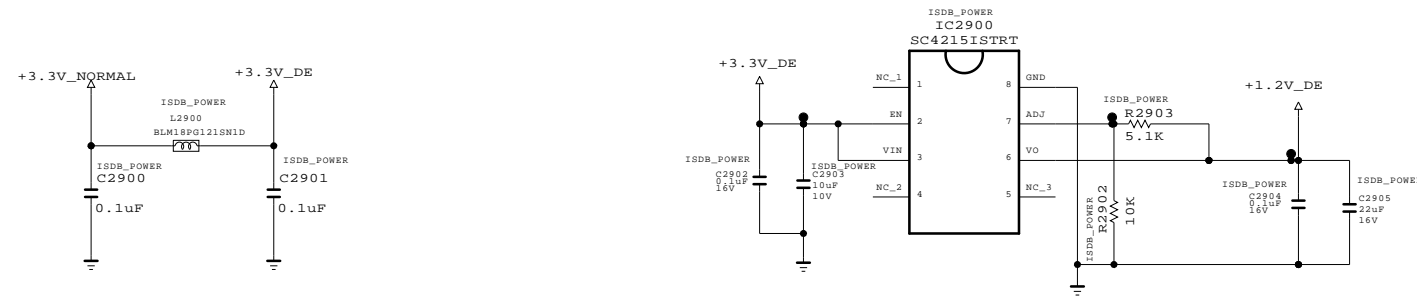

# Panasonic Demodulator Power (3.3V, 1.2V)

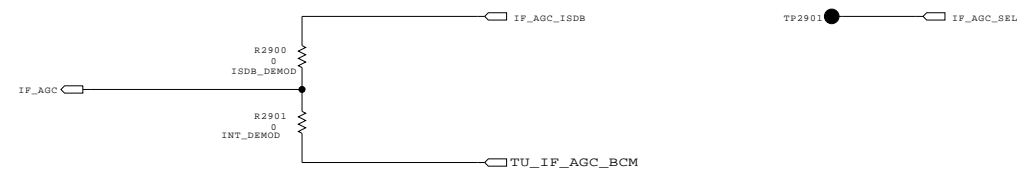

## IF AGC SELECTION



THE  SYMBOL MARK OF THIS SCHEMATIC DIAGRAM INCORPORATES SPECIAL FEATURES IMPORTANT FOR PROTECTION FROM X-RADIATION. FILRE AND ELECTRICAL SHOCK HAZARDS, WHEN SERVICING IF IS ESSENTIAL THAT ONLY MANUFACTURES SPECIFIED PARTS BE USED FOR THE CRITICAL COMPONENTS IN THE  SYMBOL MARK OF THE SCHEMATIC.

SECRET  
LGElectronics

 LG ELECTRONICS

MODEL	GP2_Saturn7M	DATE	Ver. 1.0
BLOCK	Demodulator	SHEET	29 /

# USB 2 OPTION

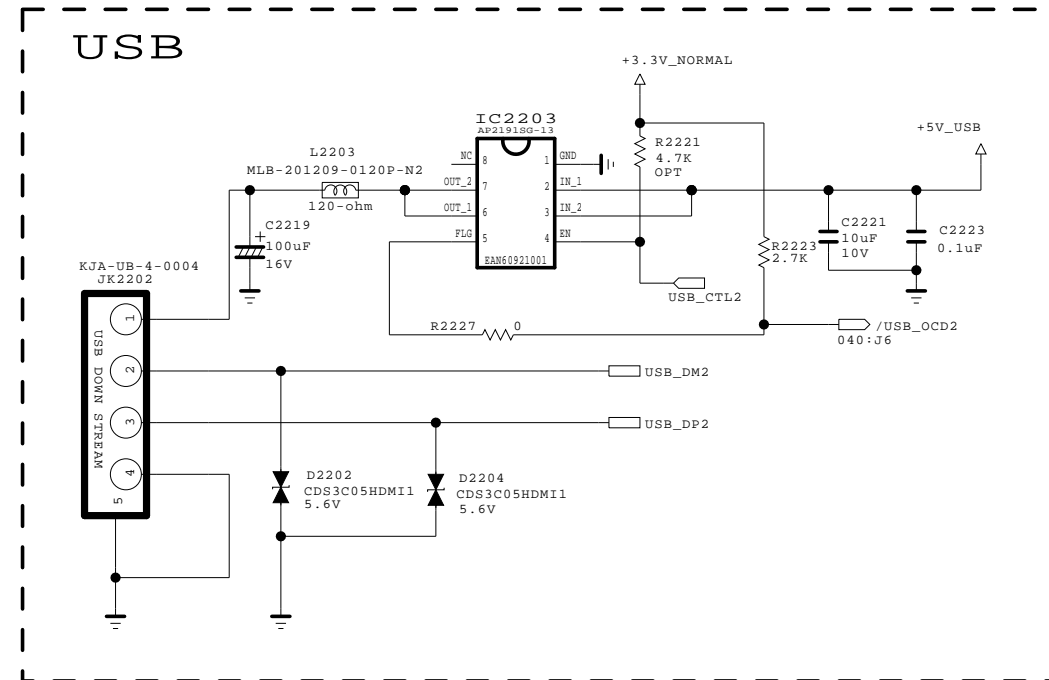
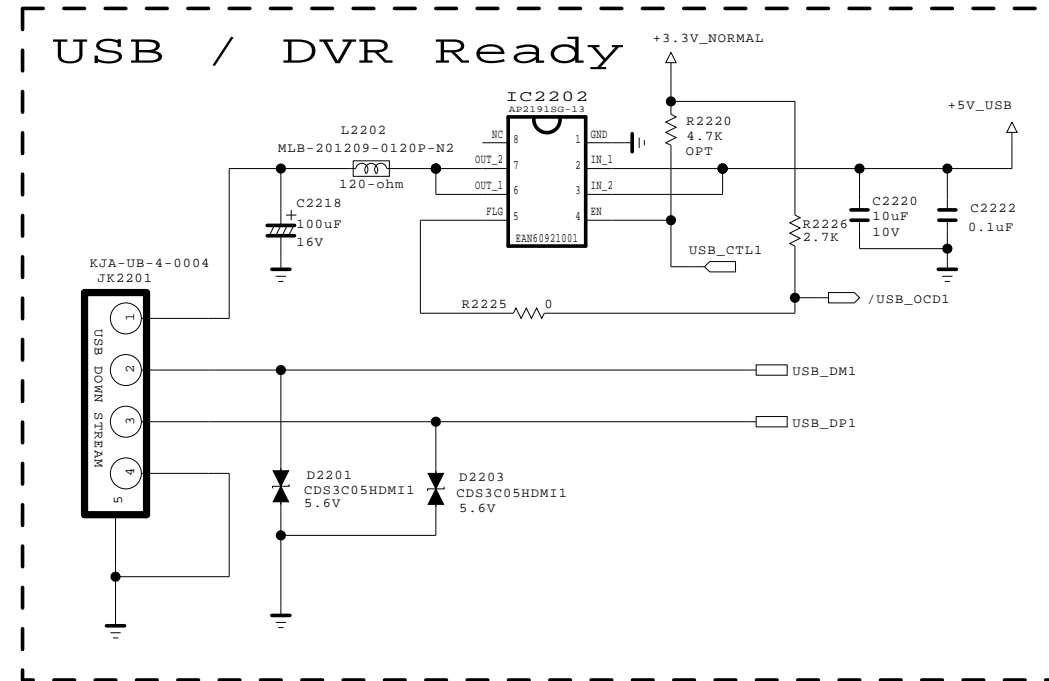
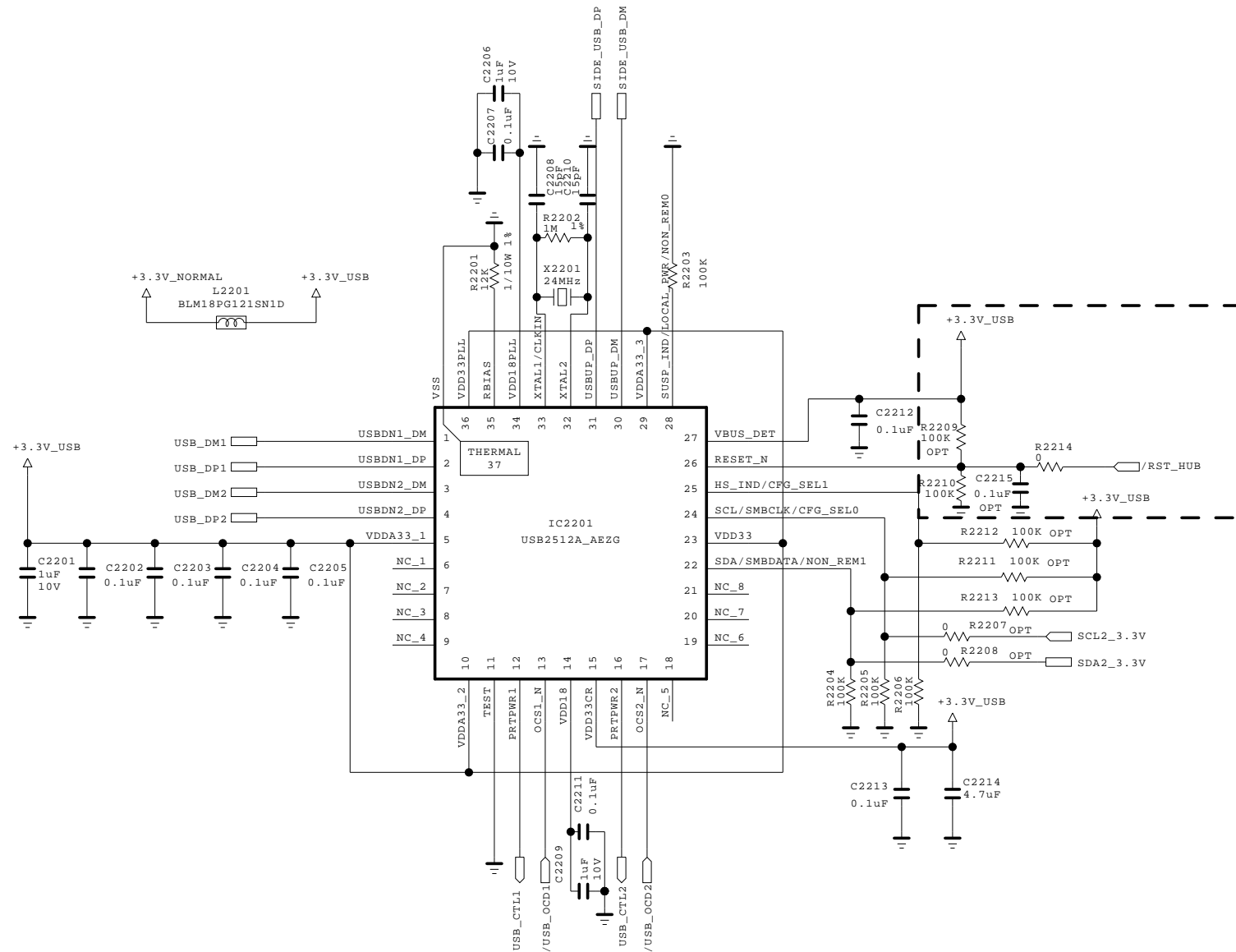

THE SYMBOL MARK OF THIS SCHEMATIC DIAGRAM INCORPORATES SPECIAL FEATURES IMPORTANT FOR PROTECTION FROM X-RADIATION. FILRE AND ELECTRICAL SHOCK HAZARDS, WHEN SERVICING IF IS ESSENTIAL THAT ONLY MANUFACTURES SPECIFIED PARTS BE USED FOR THE CRITICAL COMPONENTS IN THE SYMBOL MARK OF THE SCHEMATIC.

SECRET  
LGElectronics



MODEL		DATE	
BLOCK		SHEET	40 /

BLUETOOTH FOR BCM

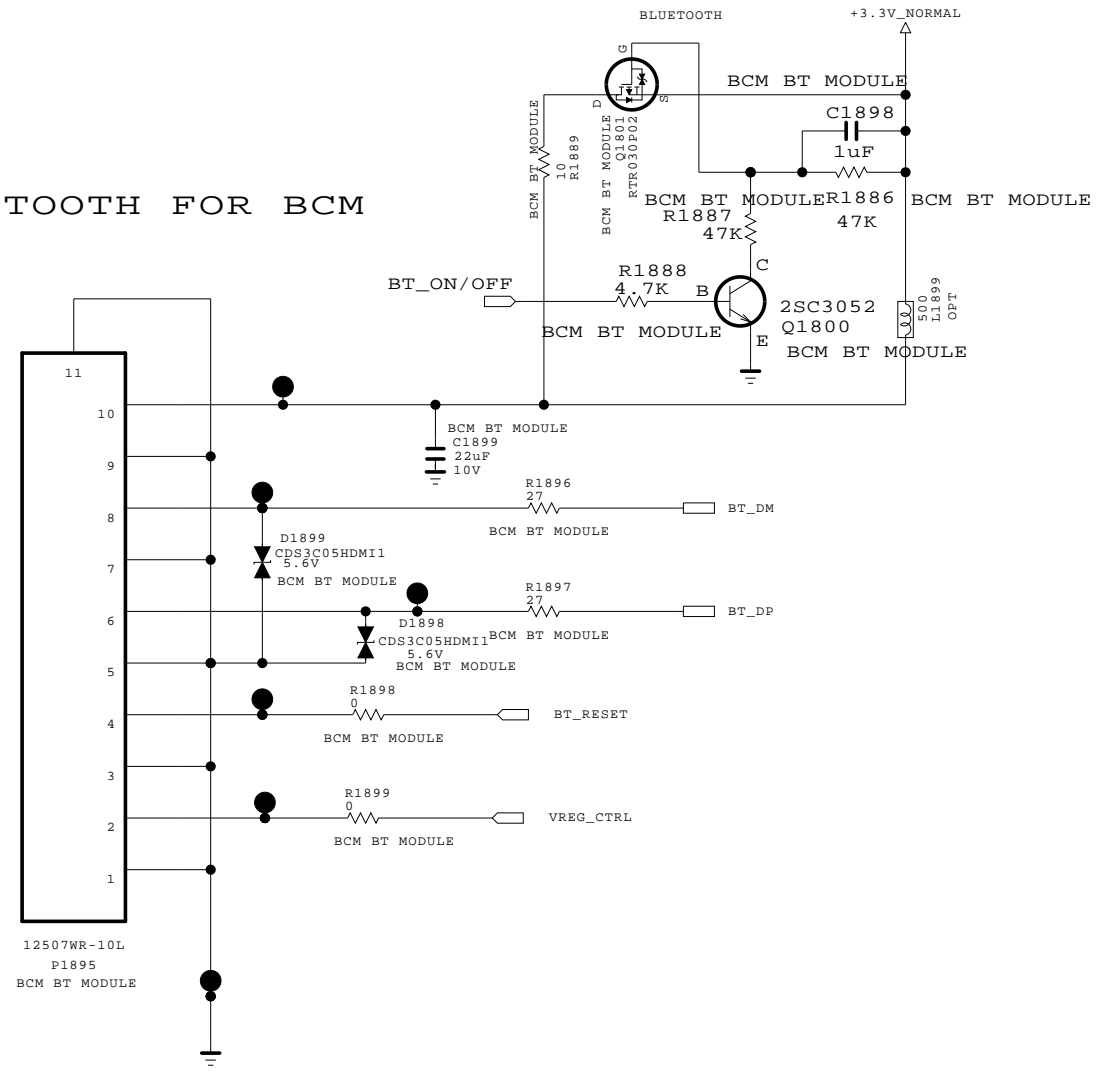

THE ⚠ SYMBOL MARK OF THIS SCHEMATIC DIAGRAM INCORPORATES SPECIAL FEATURES IMPORTANT FOR PROTECTION FROM X-RADIATION. FILRE AND ELECTRICAL SHOCK HAZARDS, WHEN SERVICING IF IS ESSENTIAL THAT ONLY MANUFACTURES SPECIFIED PARTS BE USED FOR THE CRITICAL COMPONENTS IN THE ⚠ SYMBOL MARK OF THE SCHEMATIC.

SECRET	LG ELECTRONICS
LGElectronics	

MODEL		DATE	
BLOCK		SHEET	43 /

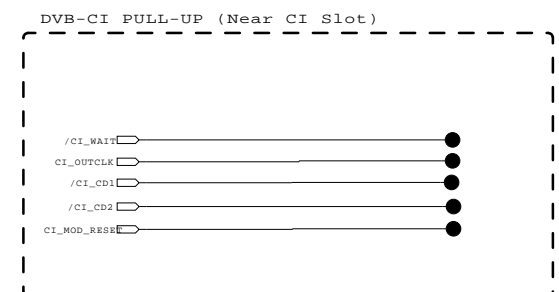
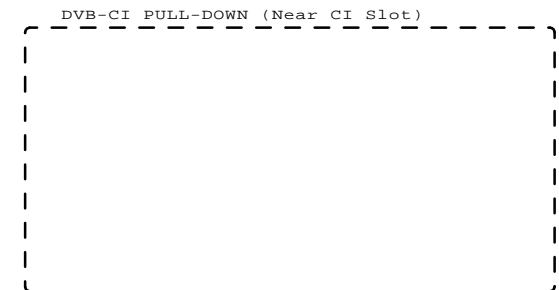
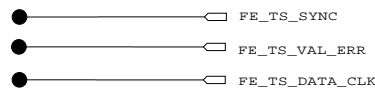
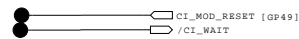
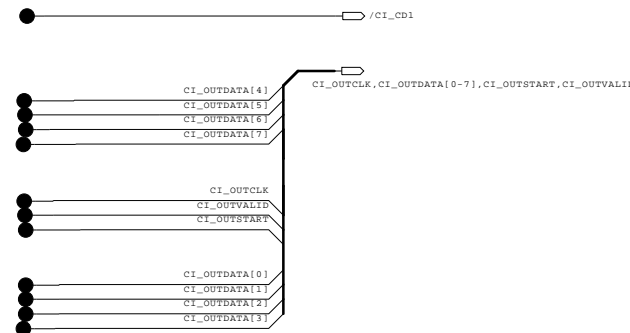
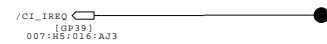
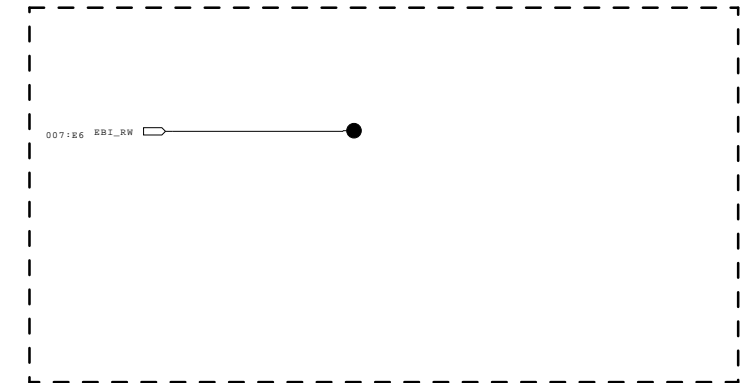
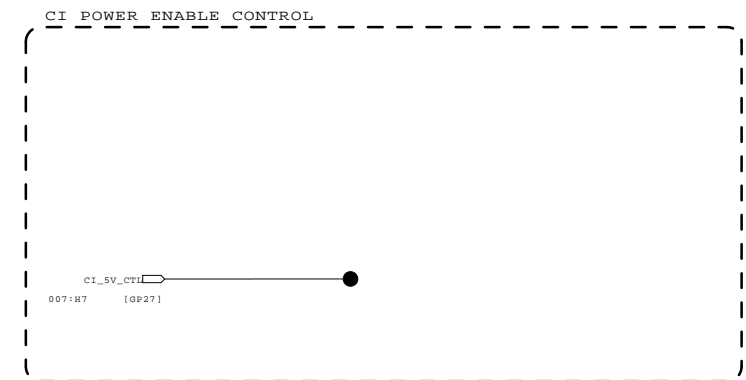
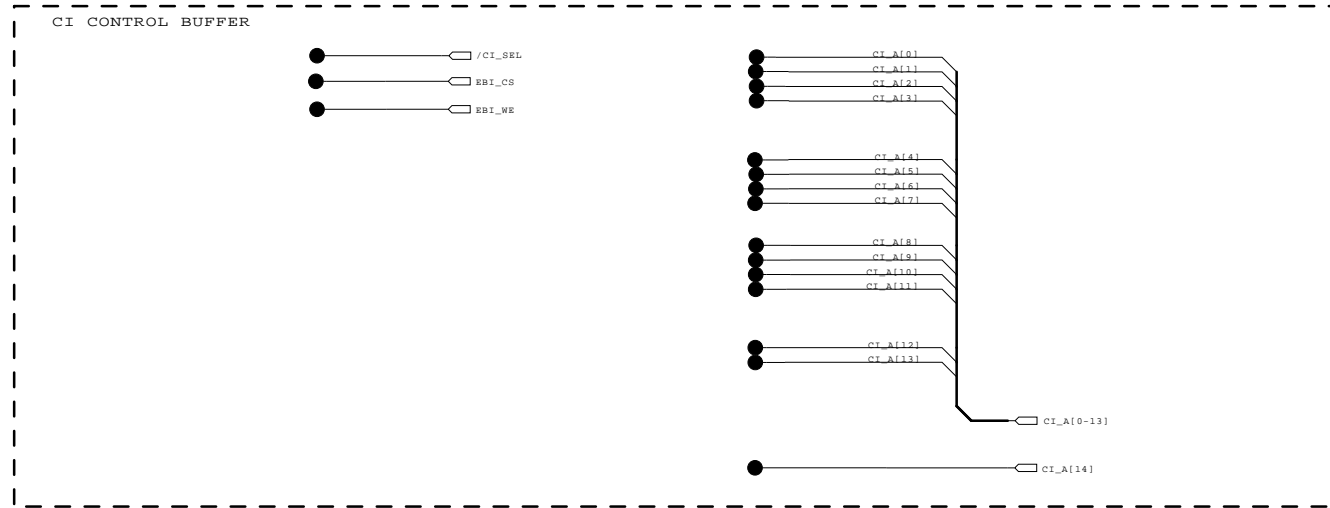

THE SYMBOL MARK OF THIS SCHEMATIC DIAGRAM INCORPORATES SPECIAL FEATURES IMPORTANT FOR PROTECTION FROM X-RADIATION. FILRE AND ELECTRICAL SHOCK HAZARDS, WHEN SERVICING IF IS ESSENTIAL THAT ONLY MANUFACTURES SPECIED PARTS BE USED FOR THE CRITICAL COMPONENTS IN THE SYMBOL MARK OF THE SCHEMATIC.

SECRET  
LGElectronics

LG ELECTRONICS

MODEL	High_Common(BCM3556)	DATE	2009.10.19
BLOCK	Non_CI	SHEET	46 /



From BCM 480Hz

[51Pin LVDS Connector]  
(For FHD 60/120Hz)

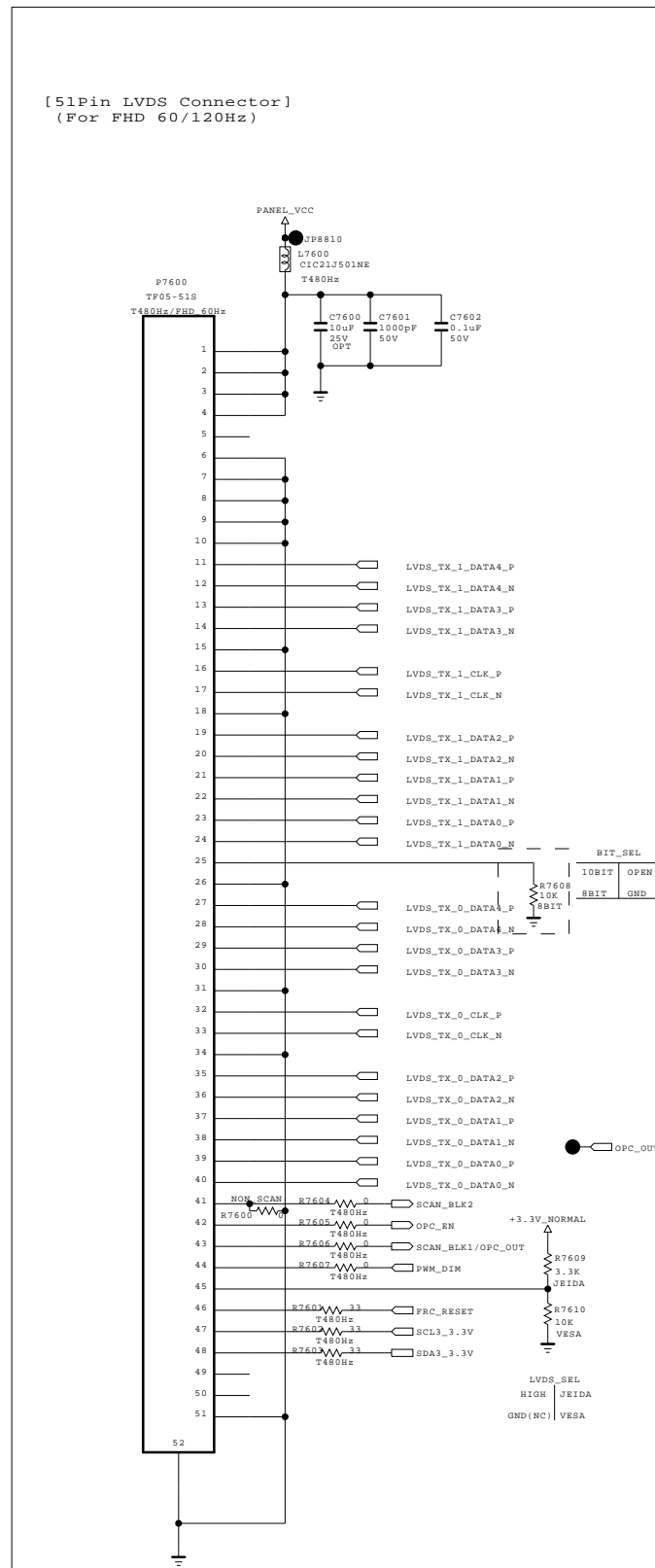

THE  $\Delta$  SYMBOL MARK OF THIS SCHEMATIC DIAGRAM INCORPORATES SPECIAL FEATURES IMPORTANT FOR PROTECTION FROM X-RADIATION. FILRE AND ELECTRICAL SHOCK HAZARDS, WHEN SERVICING IF IS ESSENTIAL THAT ONLY MANUFACTURES SPECIFIED PARTS BE USED FOR THE CRITICAL COMPONENTS IN THE  $\Delta$  SYMBOL MARK OF THE SCHEMATIC.

SECRET  
LGElectronics

LG ELECTRONICS

MODEL		DATE	
BLOCK		SHEET	35 /

LVDS

[51Pin LVDS Connector]  
(For FHD 60/120Hz)

[41Pin LVDS Connector]  
(For FHD 120Hz)

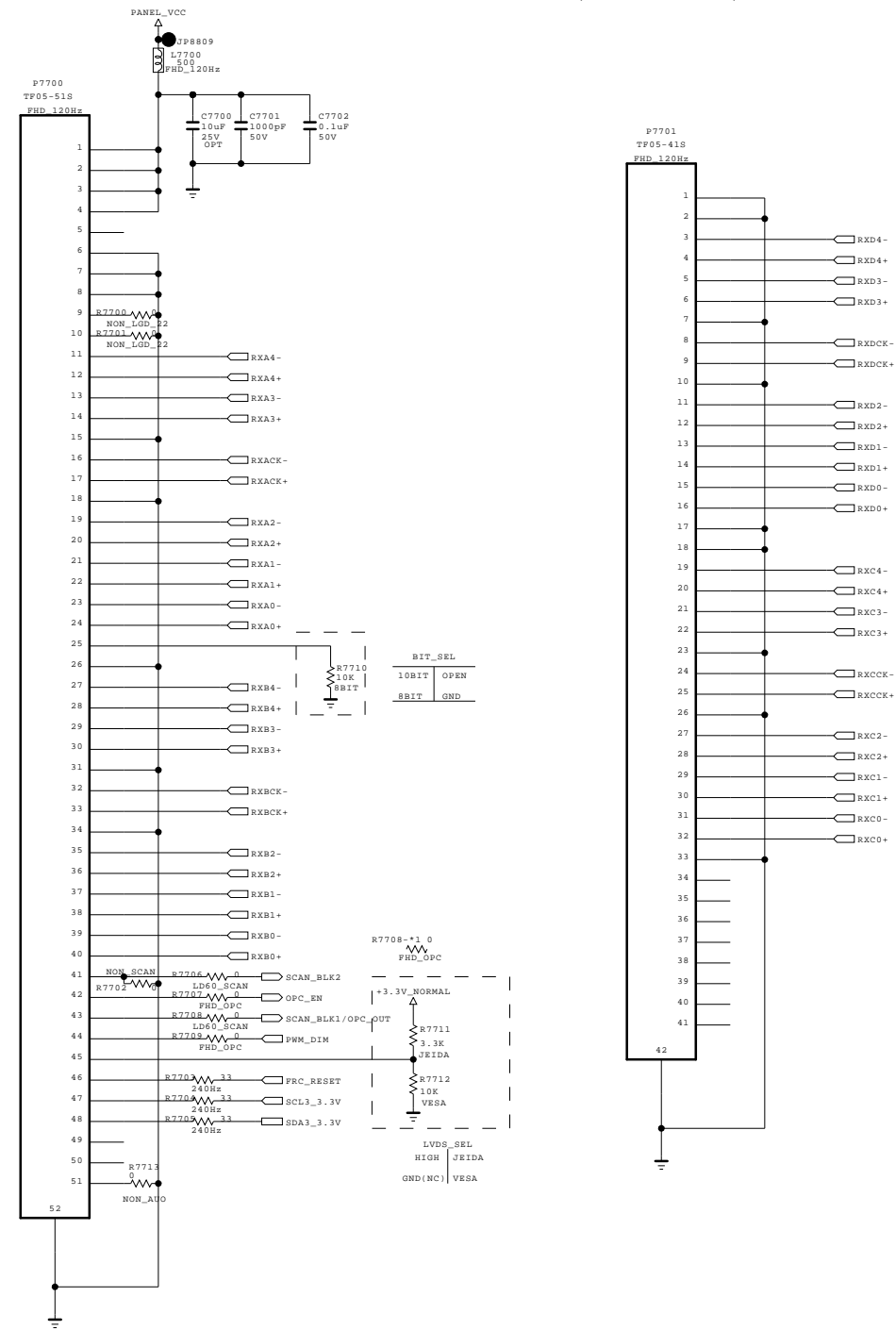

THE  $\Delta$  SYMBOL MARK OF THIS SCHEMATIC DIAGRAM INCORPORATES SPECIAL FEATURES IMPORTANT FOR PROTECTION FROM X-RADIATION. FILRE AND ELECTRICAL SHOCK HAZARDS, WHEN SERVICING IF IS ESSENTIAL THAT ONLY MANUFACTURES SPECIFIED PARTS BE USED FOR THE CRITICAL COMPONENTS IN THE  $\Delta$  SYMBOL MARK OF THE SCHEMATIC.

SECRET  
LGElectronics



MODEL		DATE	
BLOCK		SHEET	35 /

# FROM LIPS & POWER B/D

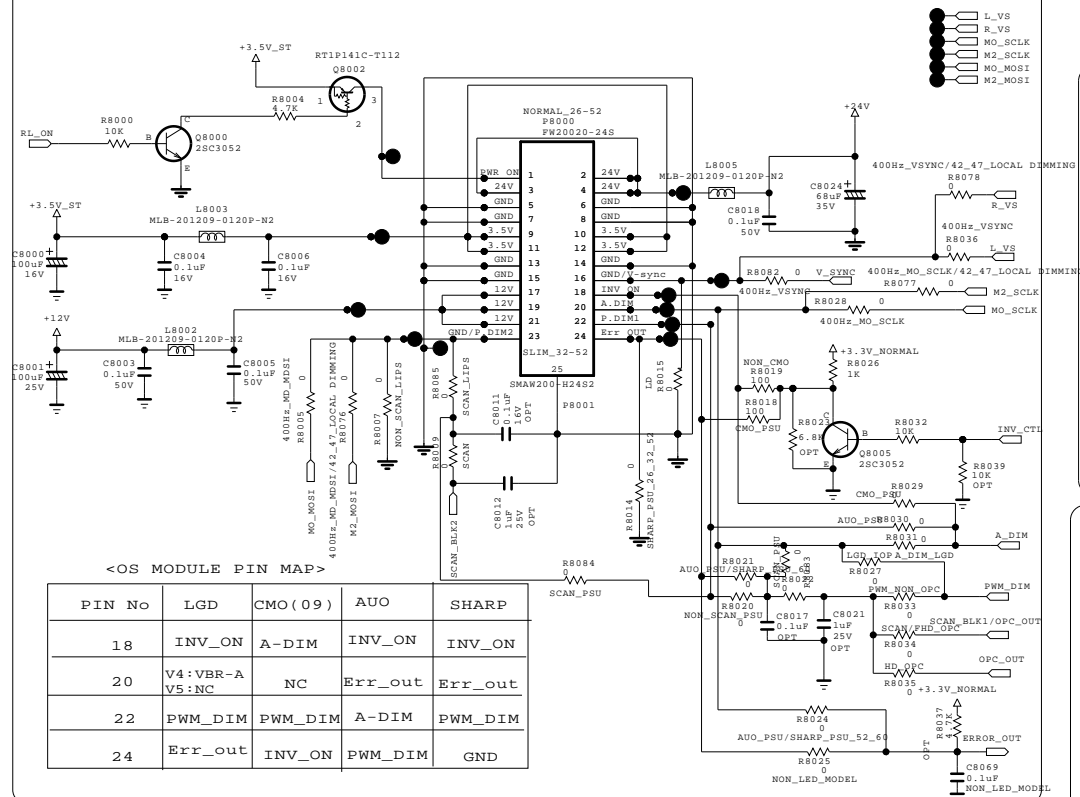

<OS MODULE PIN MAP>

PIN No	LGD	CMO (09)	AUO	SHARP
18	INV_ON	A-DIM	INV_ON	INV_ON
20	V4:VBR-A V5:NC	NC	Err_out	Err_out
22	PWM_DIM	PWM_DIM	A-DIM	PWM_DIM
24	Err_out	INV_ON	PWM_DIM	GND

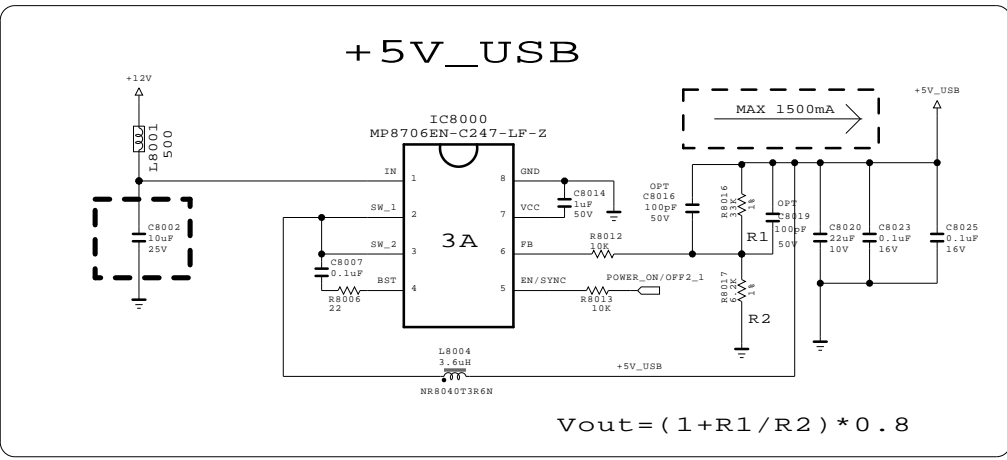
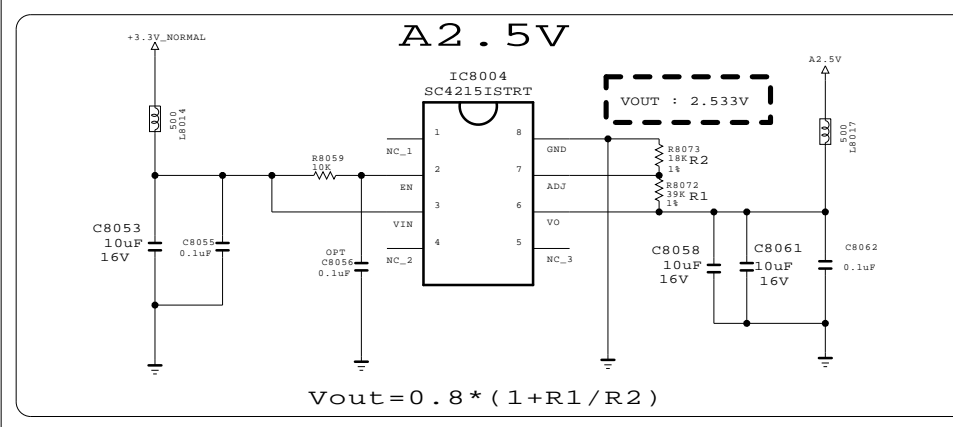
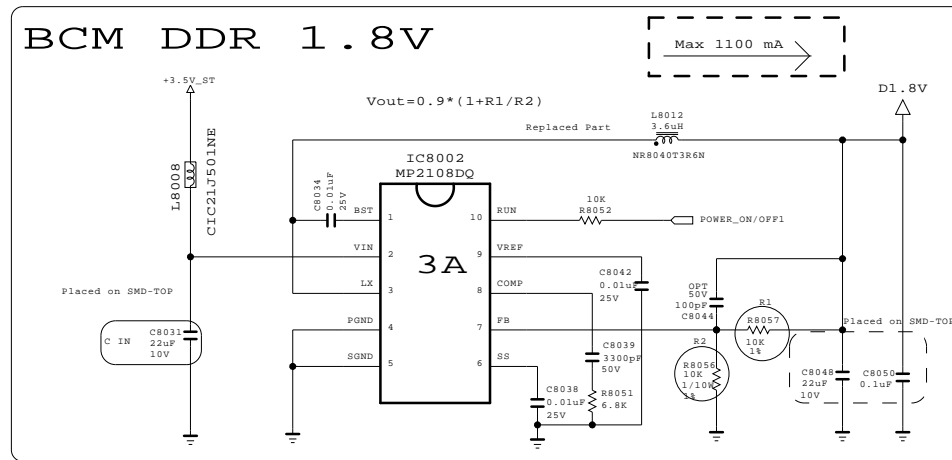
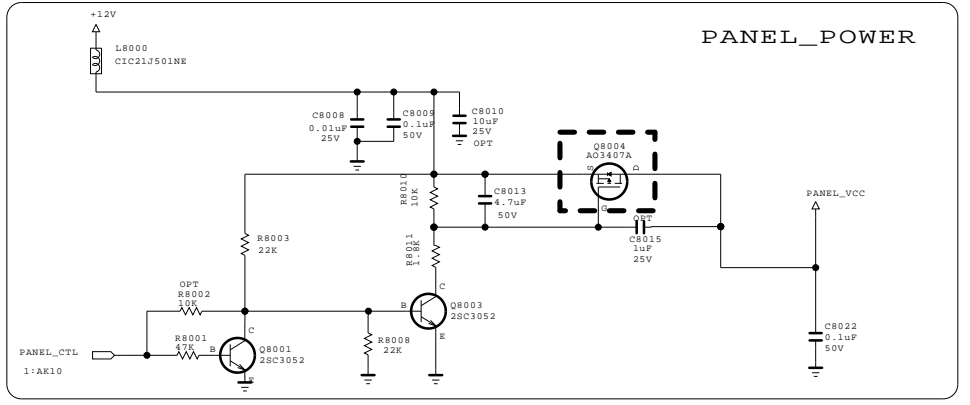
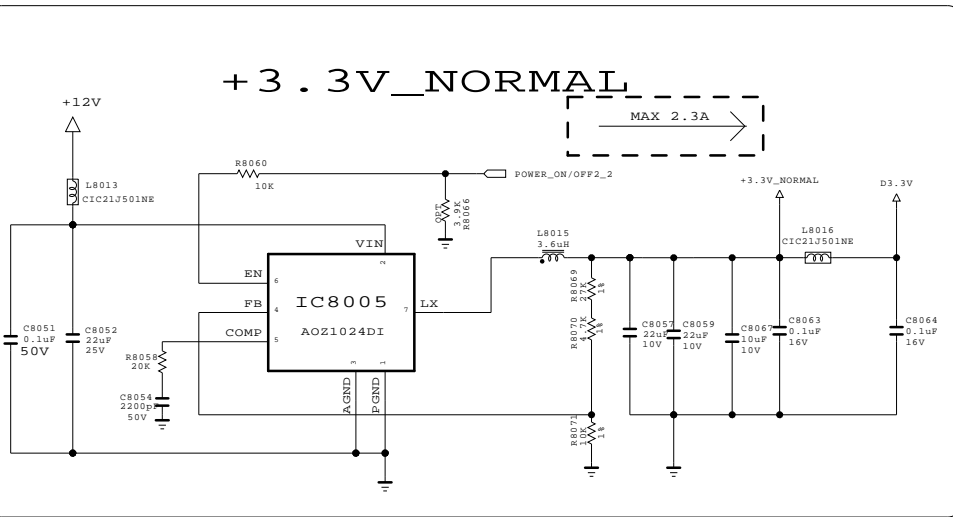
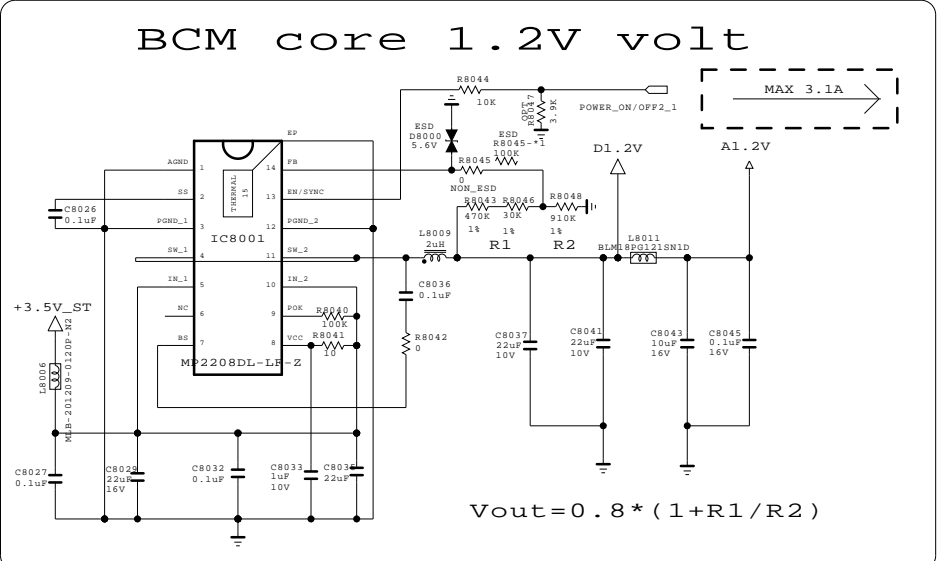
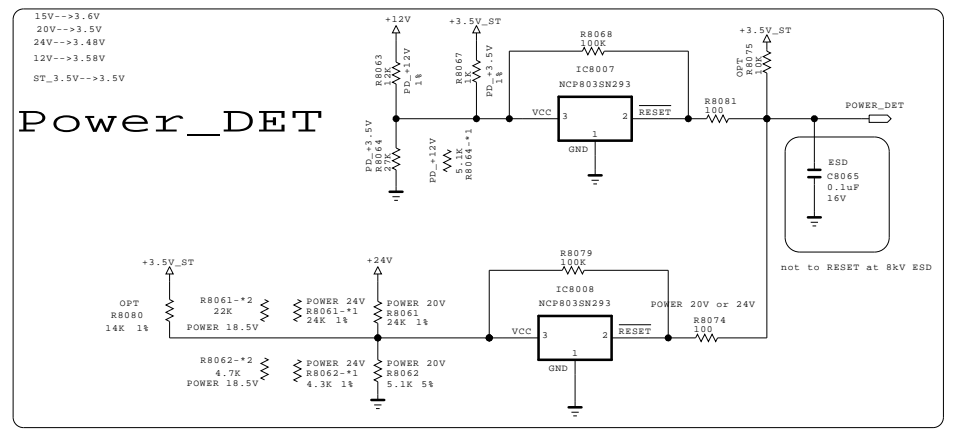
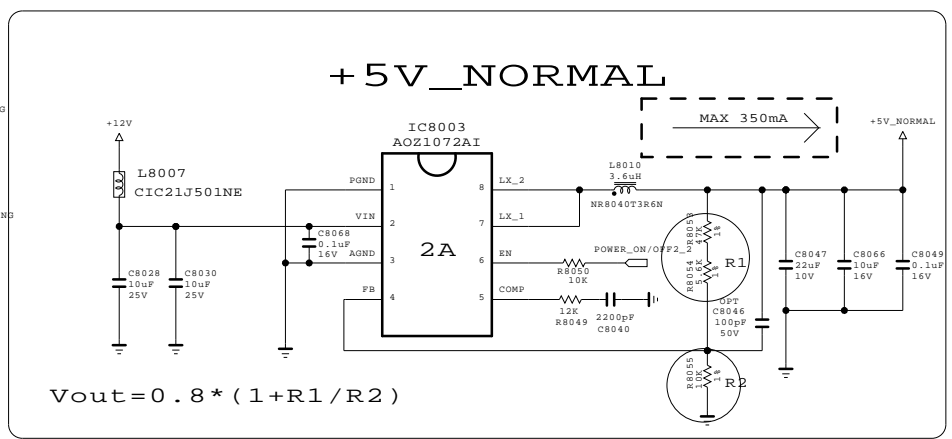

THE  $\Delta$  SYMBOL MARK OF THIS SCHEMATIC DIAGRAM INCORPORATES SPECIAL FEATURES IMPORTANT FOR PROTECTION FROM X-RADIATION. FILRE AND ELECTRICAL SHOCK HAZARDS, WHEN SERVICING IF IS ESSENTIAL THAT ONLY MANUFACTURES SPECIFIED PARTS BE USED FOR THE CRITICAL COMPONENTS IN THE  $\Delta$  SYMBOL MARK OF THE SCHEMATIC.

SECRET  
LGElectronics



MODEL	BCM (EUROBBTV)	DATE	
BLOCK	POWER	SHEET	15



# IR & KEY

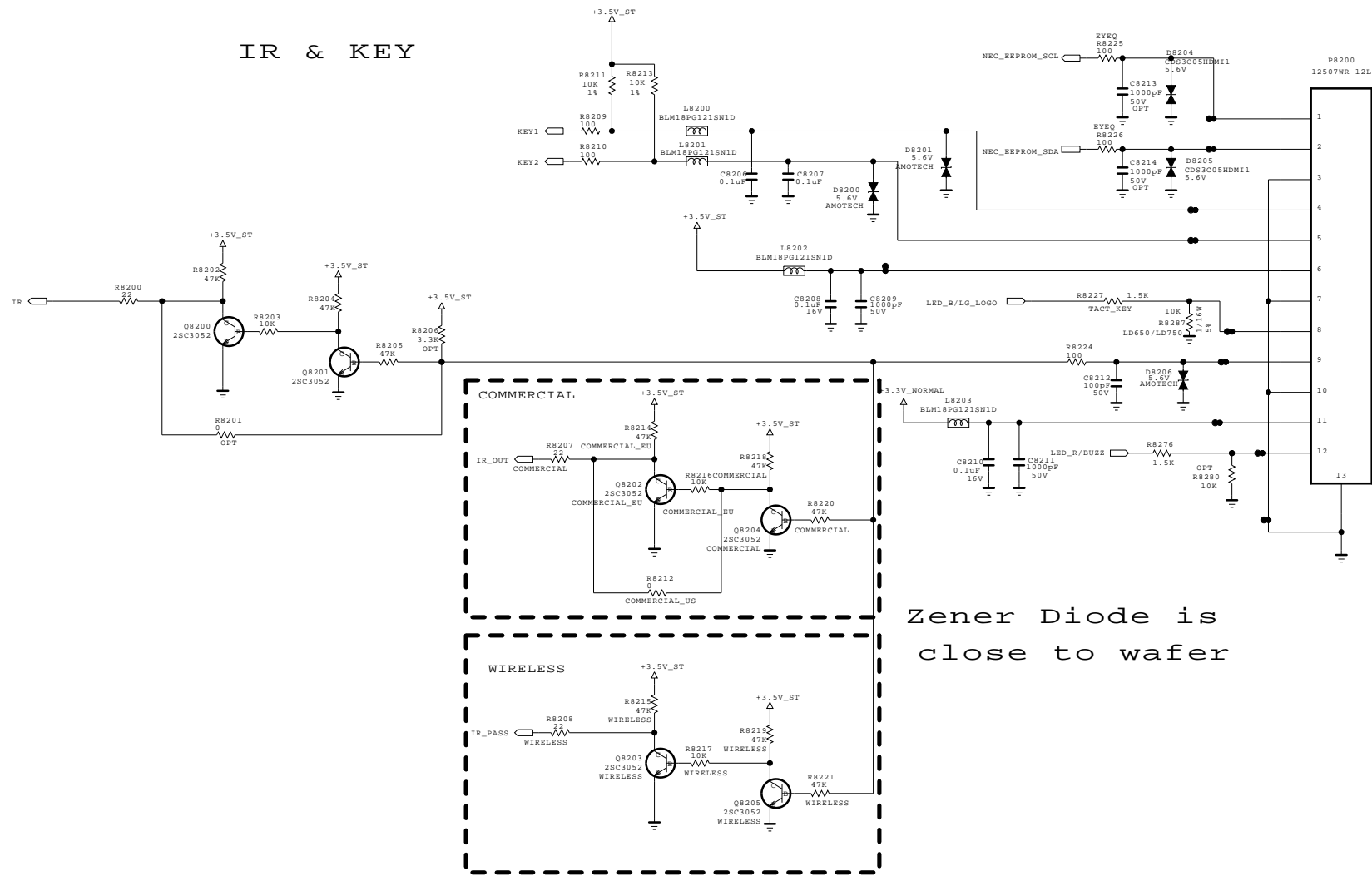

# ETHERNET CONNECT

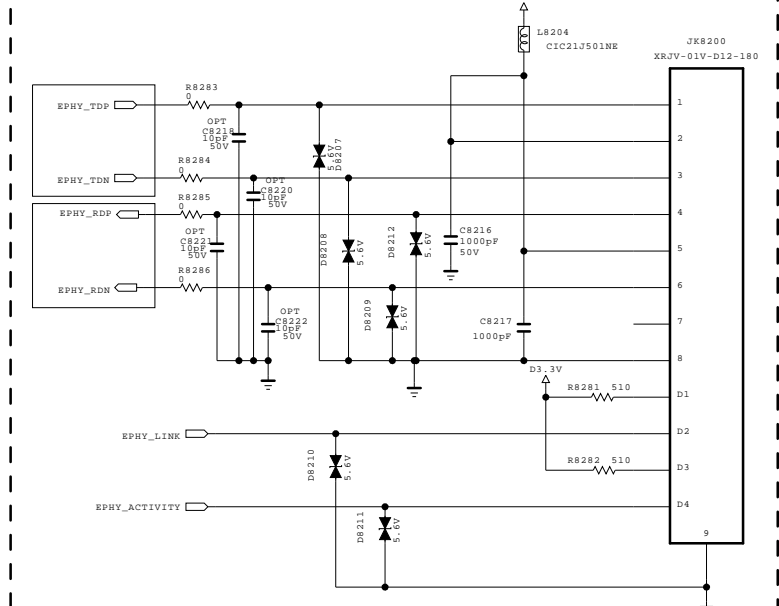

Trace impedance : 100 ohm differential impedance to GND plane  
 5 mils trace width with 7 mils air gap on P/N pair.  
 Adjacent TX/RX differential pairs should be separated by more than 15 mils to each other

# RS232C

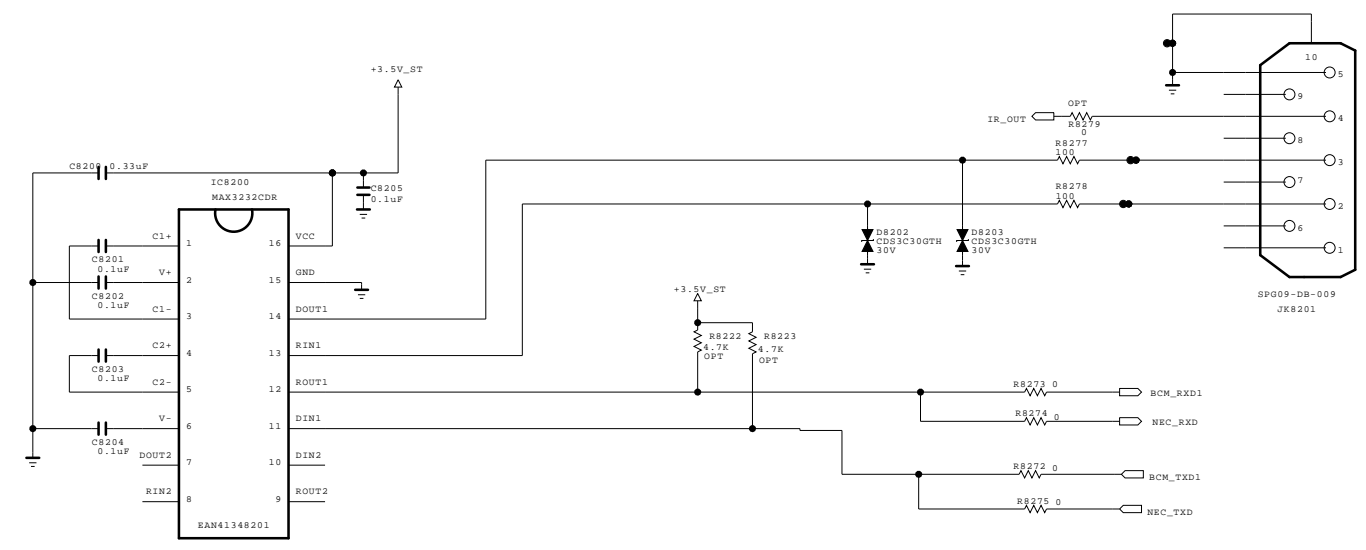

THE  $\Delta$  SYMBOL MARK OF THIS SCHEMATIC DIAGRAM INCORPORATES SPECIAL FEATURES IMPORTANT FOR PROTECTION FROM X-RADIATION. FILRE AND ELECTRICAL SHOCK HAZARDS, WHEN SERVICING IF IS ESSENTIAL THAT ONLY MANUFACTURES SPECIED PARTS BE USED FOR THE CRITICAL COMPONENTS IN THE  $\Delta$  SYMBOL MARK OF THE SCHEMATIC.

**SECRET**  
 LGElectronics



MODEL		DATE	
BLOCK		SHEET	/

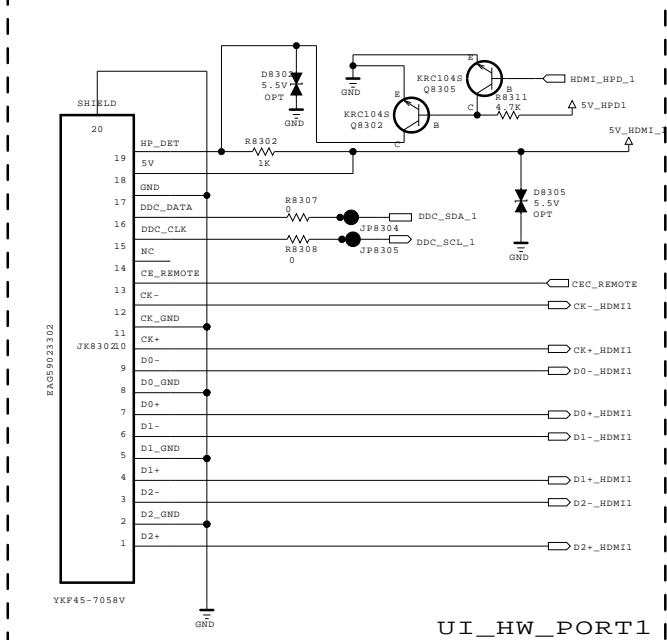

UI\_HW\_PORT1

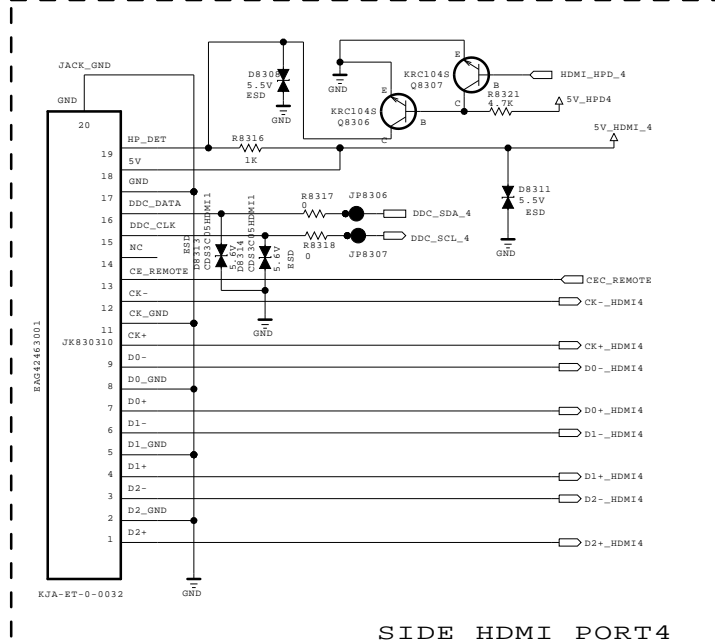

SIDE\_HDMI\_PORT4

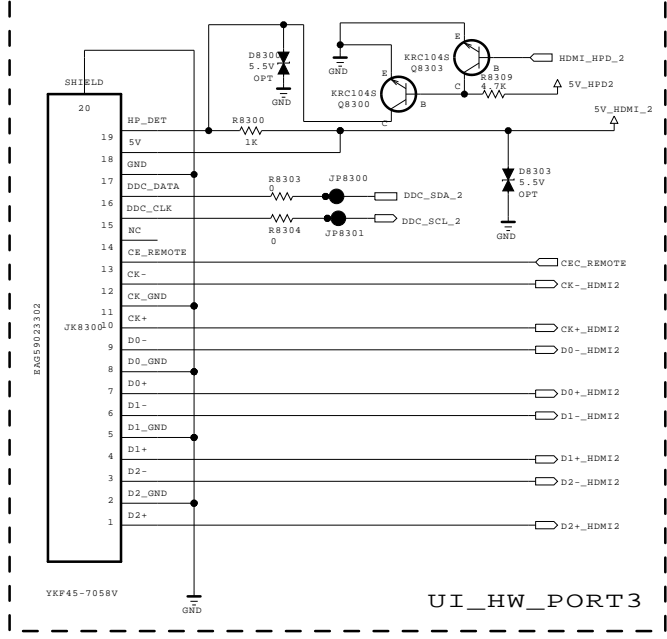

UI\_HW\_PORT3

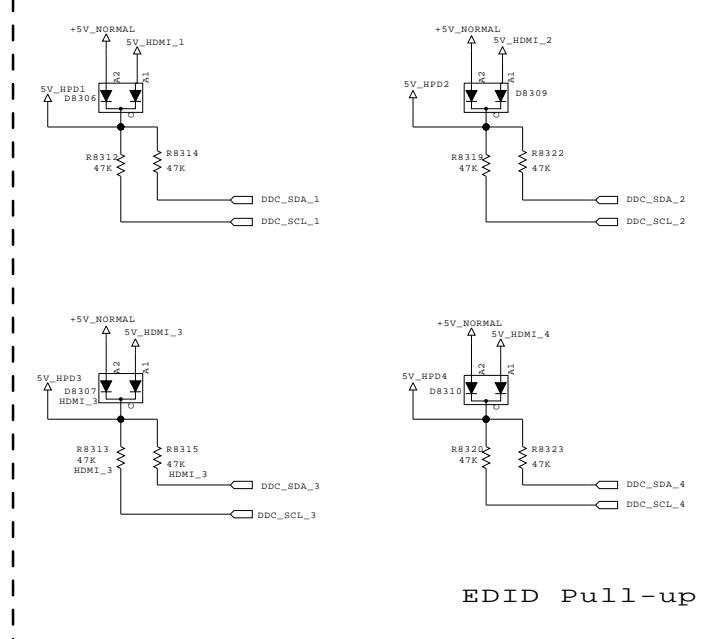

EDID Pull-up

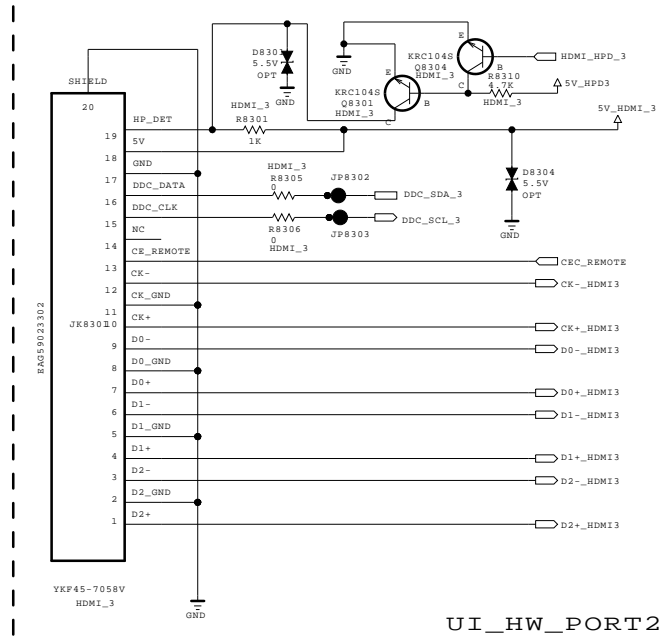

UI\_HW\_PORT2

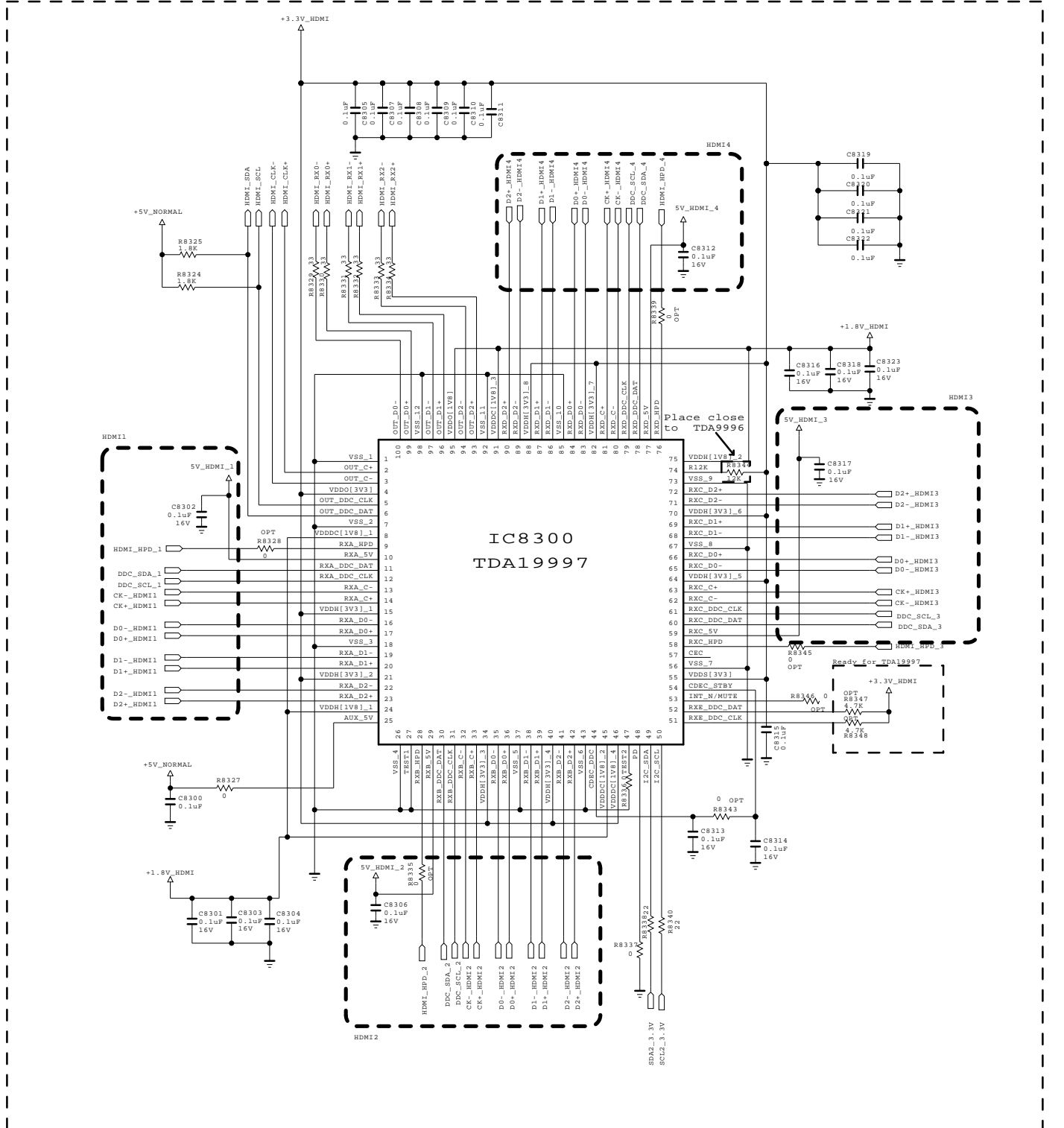
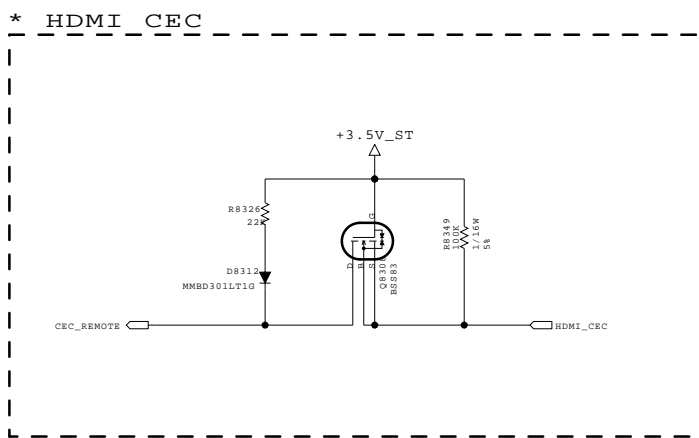

THE SYMBOL MARK OF THIS SCHEMATIC DIAGRAM INCORPORATES SPECIAL FEATURES IMPORTANT FOR PROTECTION FROM X-RADIATION. FILRE AND ELECTRICAL SHOCK HAZARDS, WHEN SERVICING IF IS ESSENTIAL THAT ONLY MANUFACTURES SPECIFIED PARTS BE USED FOR THE CRITICAL COMPONENTS IN THE SYMBOL MARK OF THE SCHEMATIC.

SECRET  
LGElectronics

LEE GI YOUNG



MODEL BLOCK	BCM (EUROBBTV)	DATE SHEET	2009.06.18
	HDMI	SHEET	8

RGB\_PC

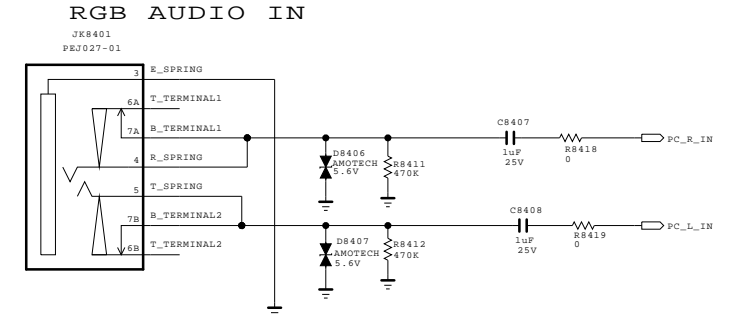
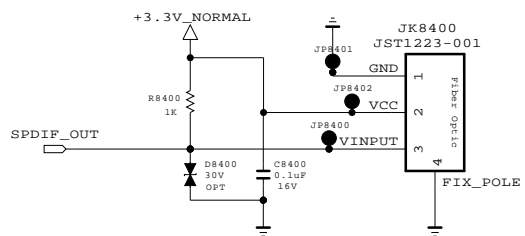
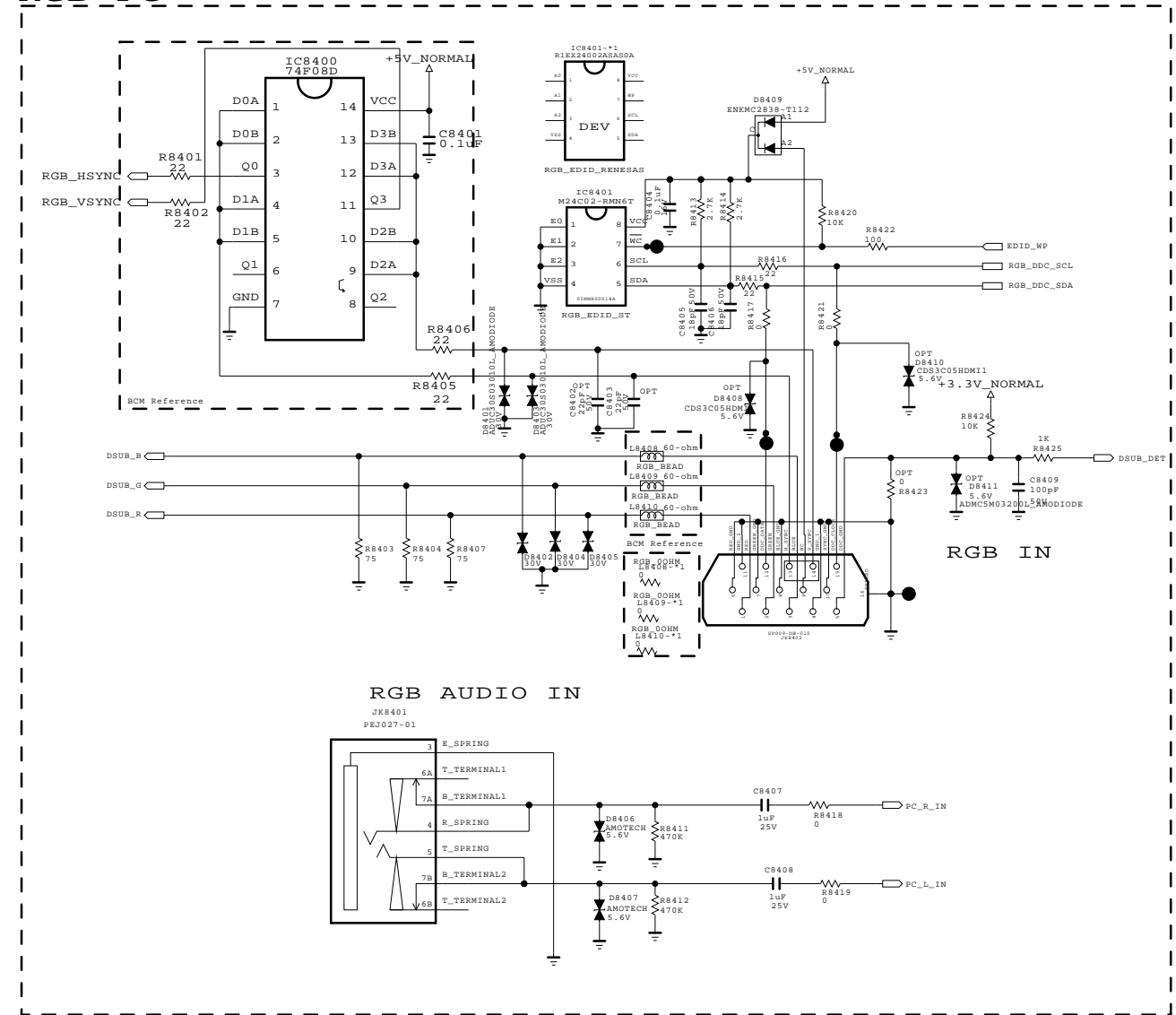

THE SYMBOL MARK OF THIS SCHEMATIC DIAGRAM INCORPORATES SPECIAL FEATURES IMPORTANT FOR PROTECTION FROM X-RADIATION. FILRE AND ELECTRICAL SHOCK HAZARDS, WHEN SERVICING IF IS ESSENTIAL THAT ONLY MANUFACTURES SPECIED PARTS BE USED FOR THE CRITICAL COMPONENTS IN THE SYMBOL MARK OF THE SCHEMATIC.

SECRET  
LGElectronics



MODEL	EUROBBTV	DATE	2009.06.18
BLOCK	ETC SUB BOARD I/F	SHEET	9 /

(New Item Developmen H:9.2mm)

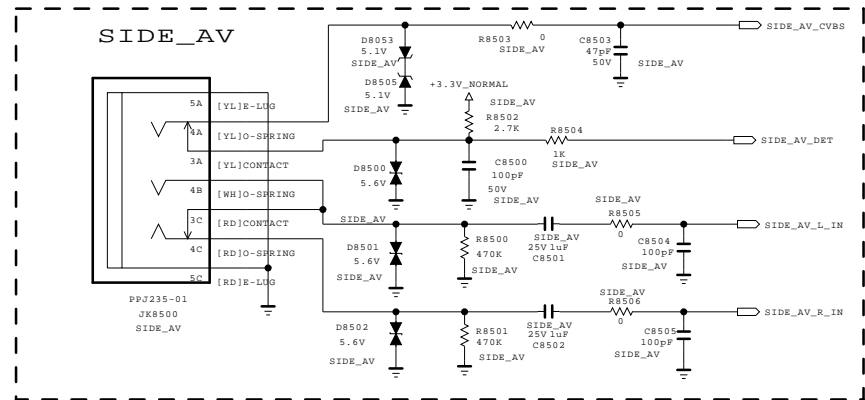

THE SYMBOL MARK OF THIS SCHEMATIC DIAGRAM INCORPORATES SPECIAL FEATURES IMPORTANT FOR PROTECTION FROM X-RADIATION. FILRE AND ELECTRICAL SHOCK HAZARDS, WHEN SERVICING IF IS ESSENTIAL THAT ONLY MANUFACTURES SPECIFIED PARTS BE USED FOR THE CRITICAL COMPONENTS IN THE SYMBOL MARK OF THE SCHEMATIC.

SECRET  
LGElectronics



MODEL		DATE	
BLOCK		SHEET	/

# WIRELESS READY MODEL

## Wireless power

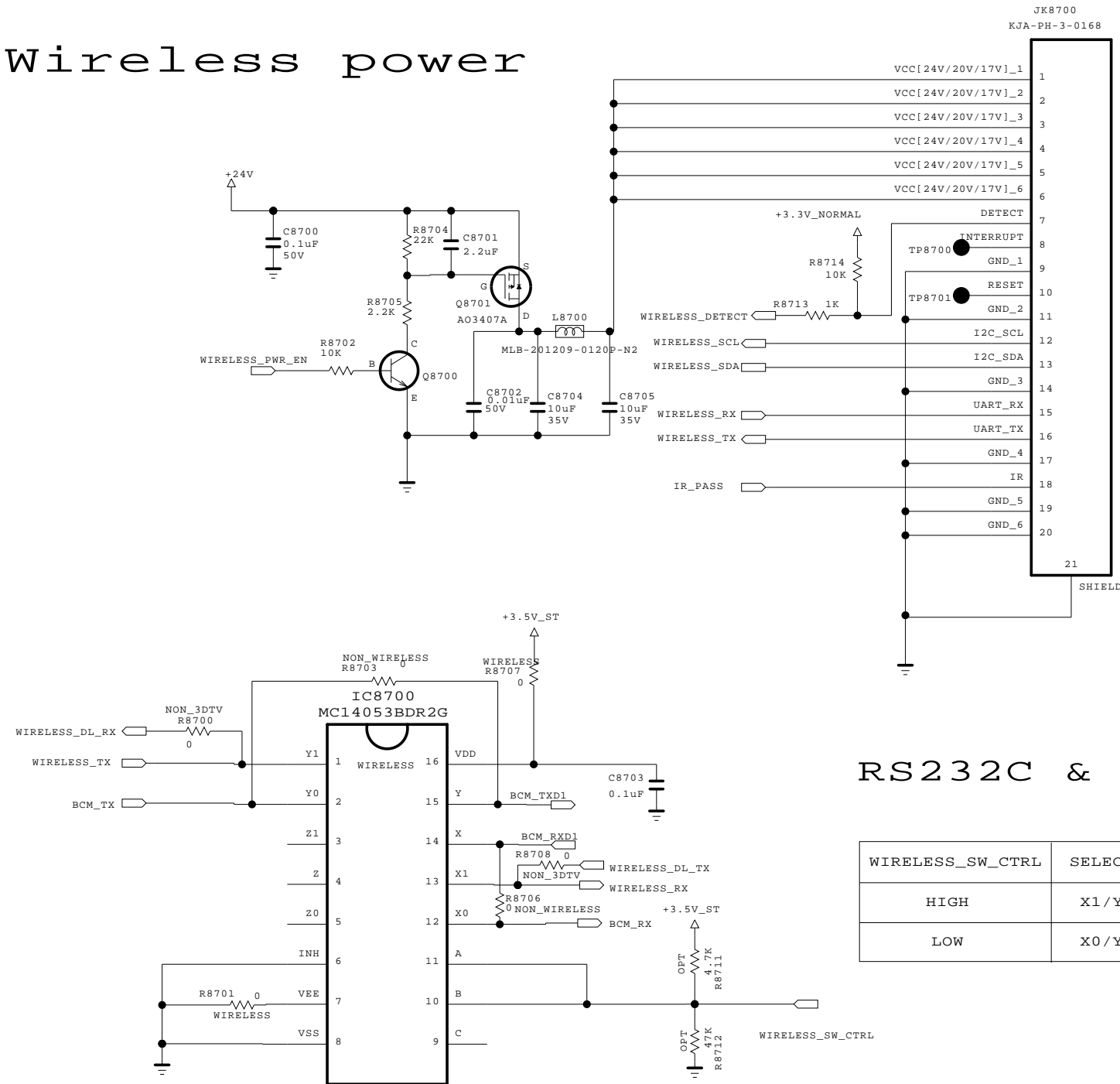

THE ⚠ SYMBOL MARK OF THIS SCHEMATIC DIAGRAM INCORPORATES SPECIAL FEATURES IMPORTANT FOR PROTECTION FROM X-RADIATION. FILRE AND ELECTRICAL SHOCK HAZARDS, WHEN SERVICING IF IS ESSENTIAL THAT ONLY MANUFACTURES SPECIFIED PARTS BE USED FOR THE CRITICAL COMPONENTS IN THE ⚠ SYMBOL MARK OF THE SCHEMATIC.

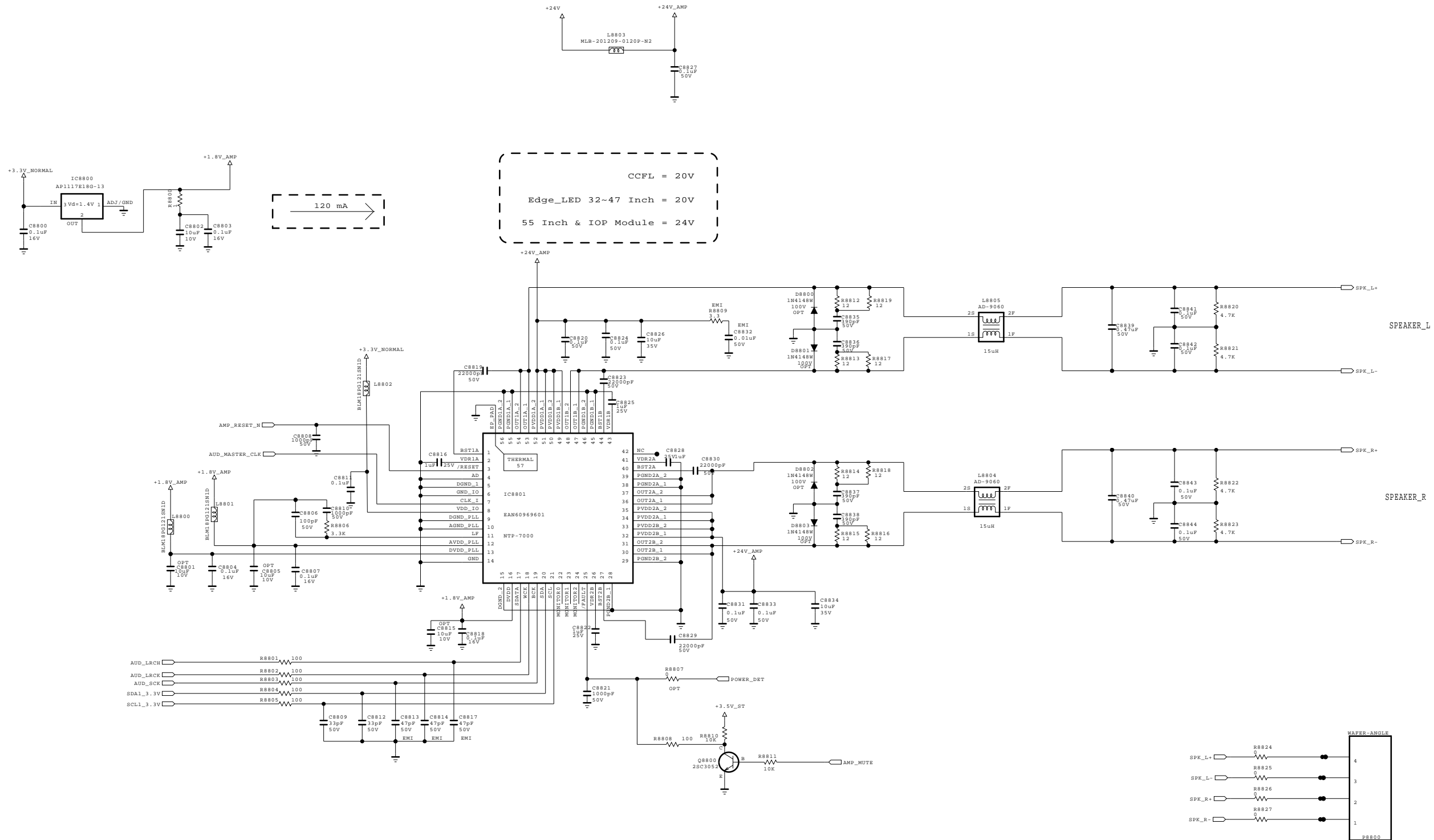

THE SYMBOL MARK OF THIS SCHEMATIC DIAGRAM INCORPORATES SPECIAL FEATURES IMPORTANT FOR PROTECTION FROM X-RADIATION. FILRE AND ELECTRICAL SHOCK HAZARDS, WHEN SERVICING IF IS ESSENTIAL THAT ONLY MANUFACTURES SPECIFIED PARTS BE USED FOR THE CRITICAL COMPONENTS IN THE SYMBOL MARK OF THE SCHEMATIC.

SECRET  
LGElectronics

KIM JONG HYUN



MODEL	BCM (EUROBBTV)	DATE	2009.06.18
BLOCK	NTP7000	SHEET	38 /

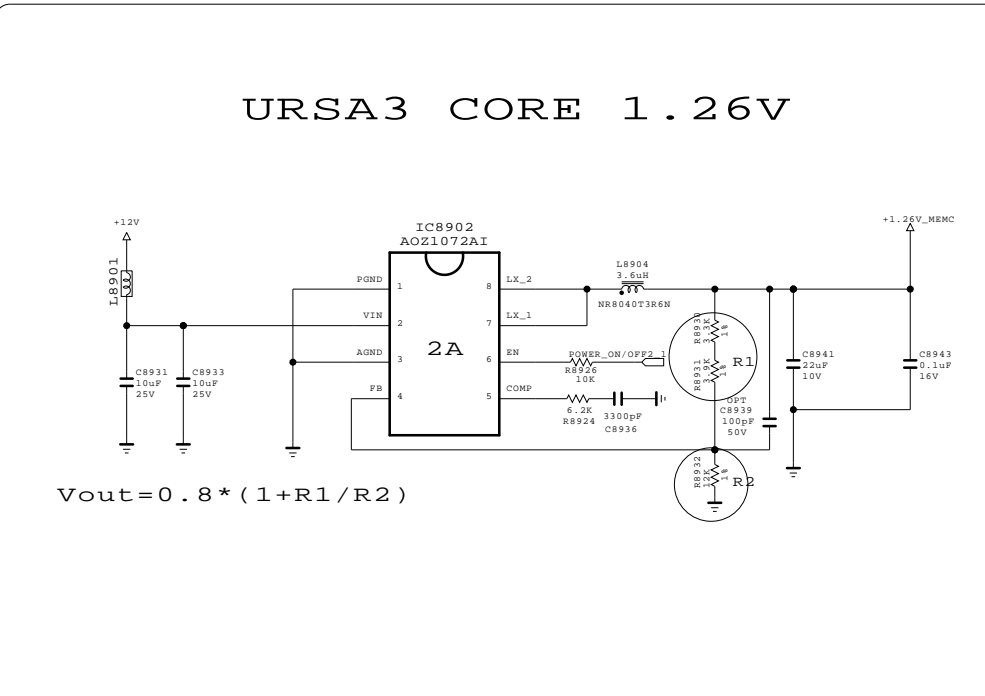
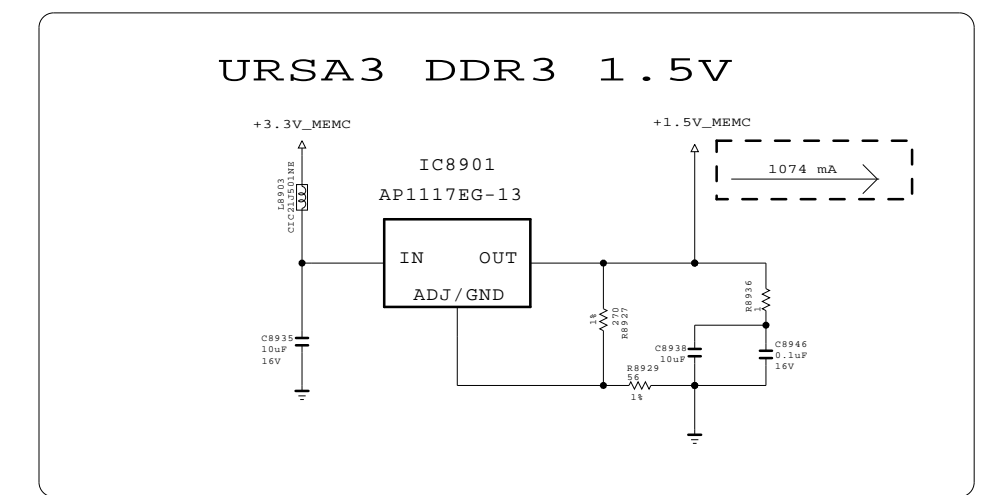
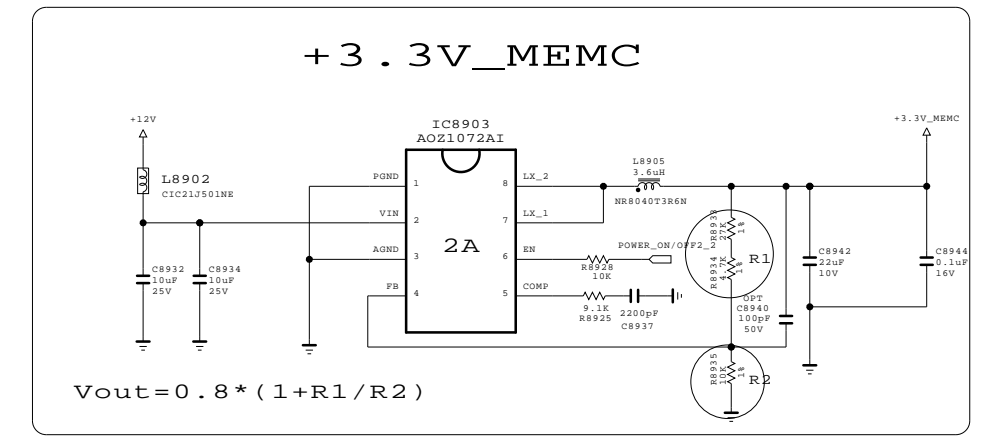
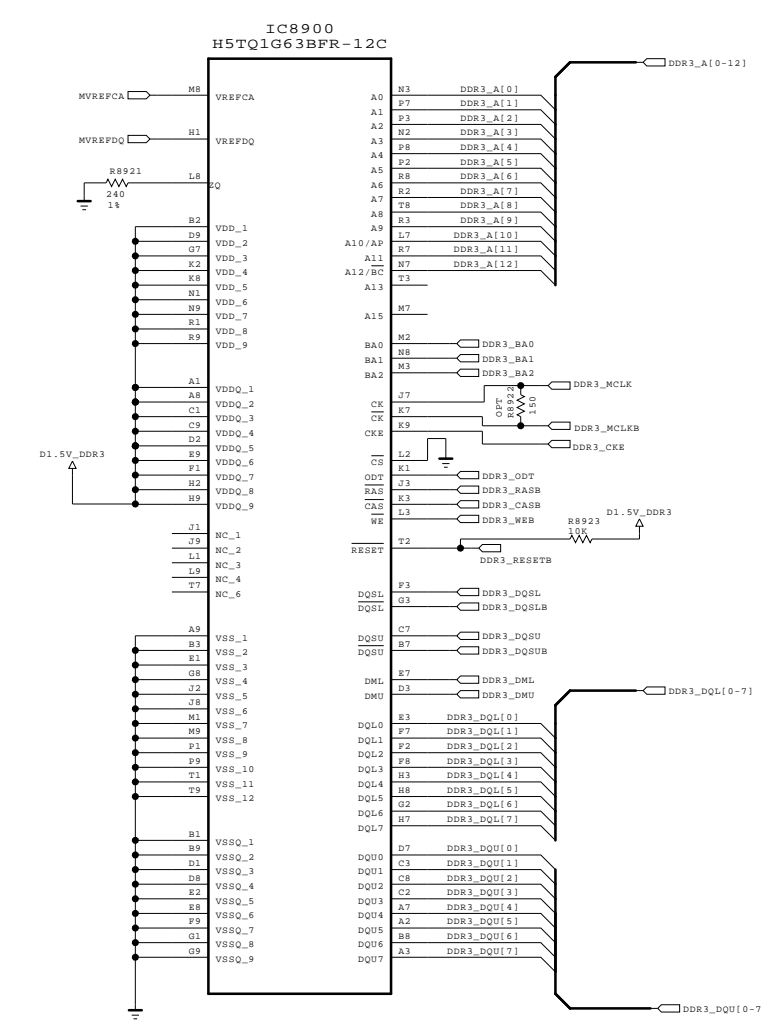
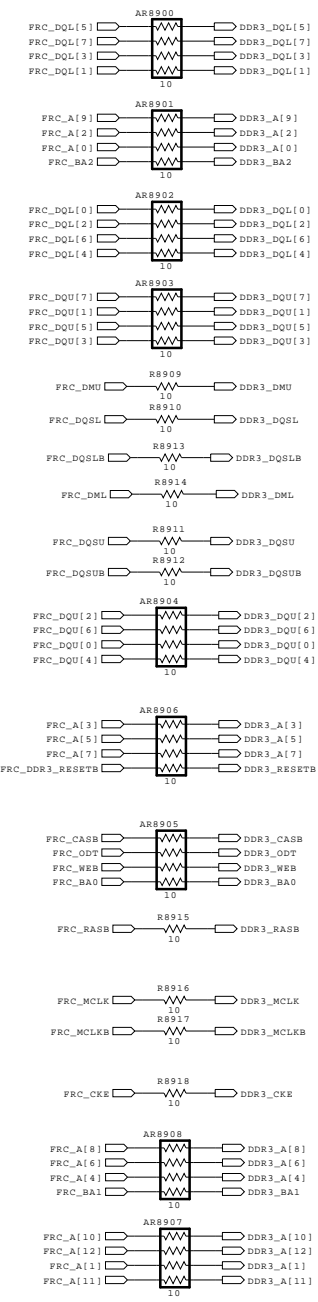
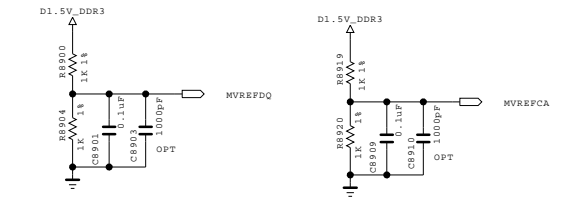
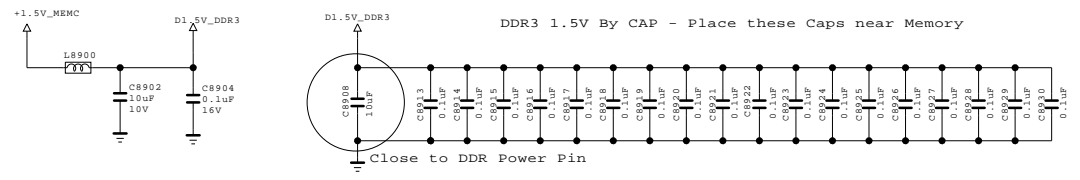

THE  $\Delta$  SYMBOL MARK OF THIS SCHEMATIC DIAGRAM INCORPORATES SPECIAL FEATURES IMPORTANT FOR PROTECTION FROM X-RADIATION. FILRE AND ELECTRICAL SHOCK HAZARDS, WHEN SERVICING IF IS ESSENTIAL THAT ONLY MANUFACTURES SPECIFIED PARTS BE USED FOR THE CRITICAL COMPONENTS IN THE  $\Delta$  SYMBOL MARK OF THE SCHEMATIC.

SECRET  
LGElectronics



MODEL	COMMON	DATE	2009.09.11
BLOCK	URSA3 DDR & Power	SHEET	89

# Serial Flash

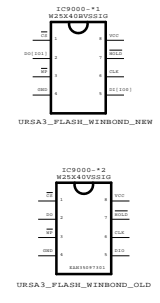
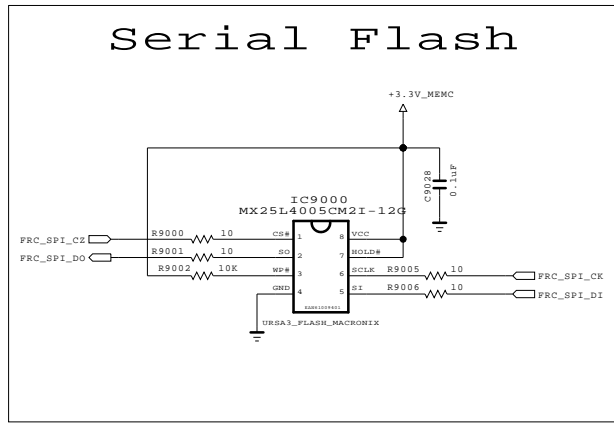

FRC OPTION	LOW	HIGH
K14	NON_MIRROR	MIRROR
T10	LVDS	MINI_LVDS
R10	GIP	MINI_GIP
R9	SCAN_OFF	SCAN_ON
U10	LD	NON_LD

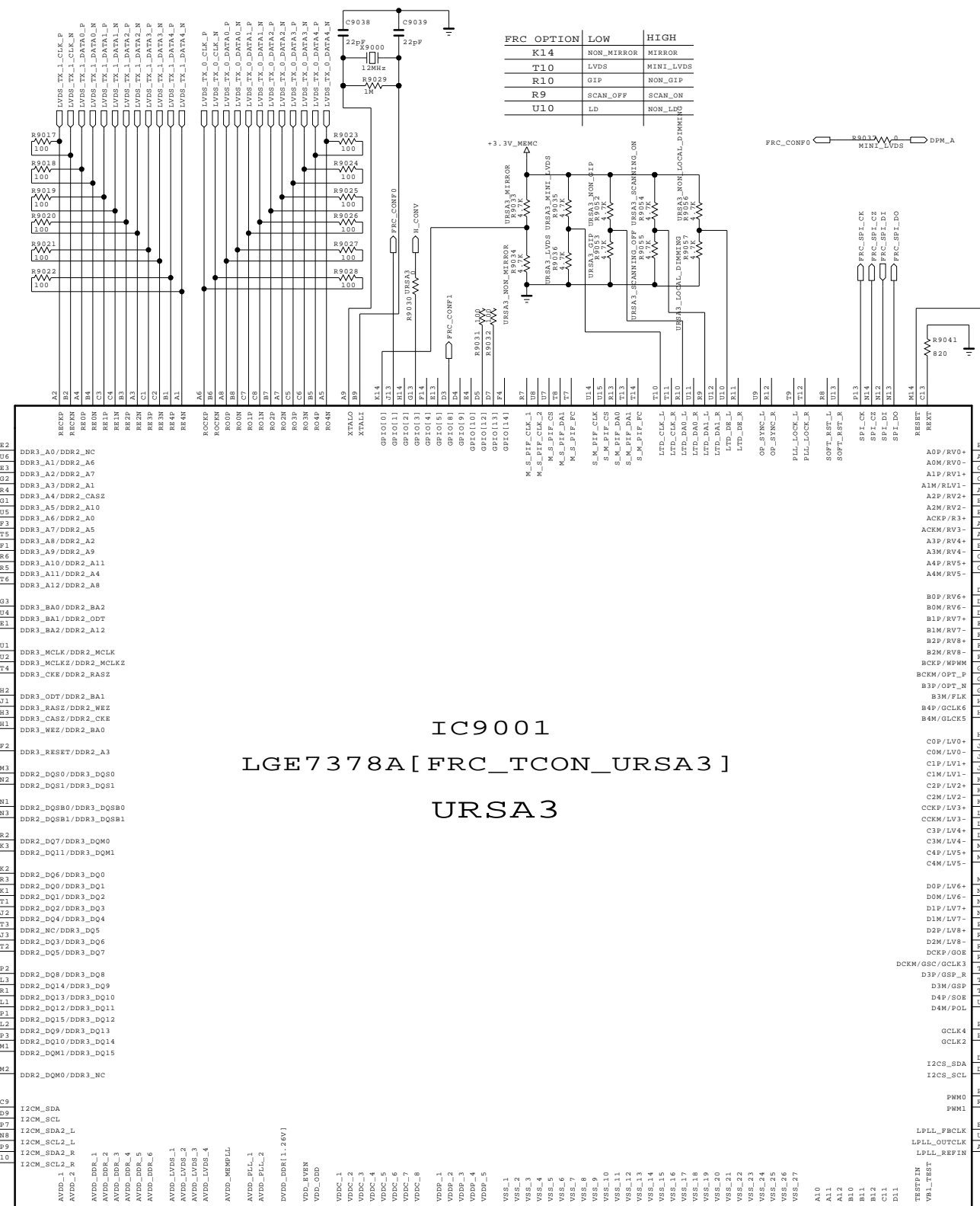
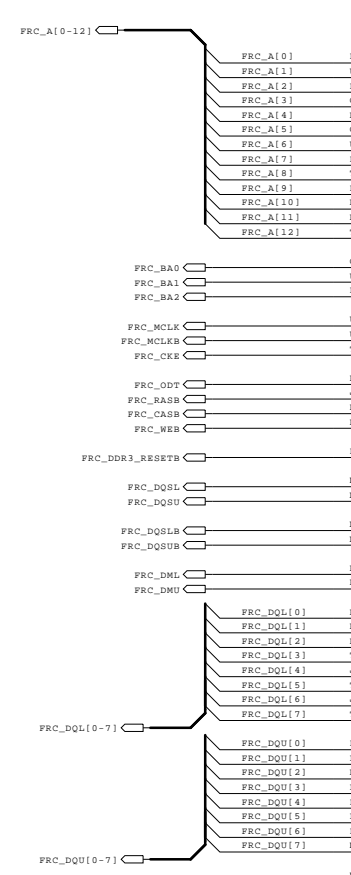
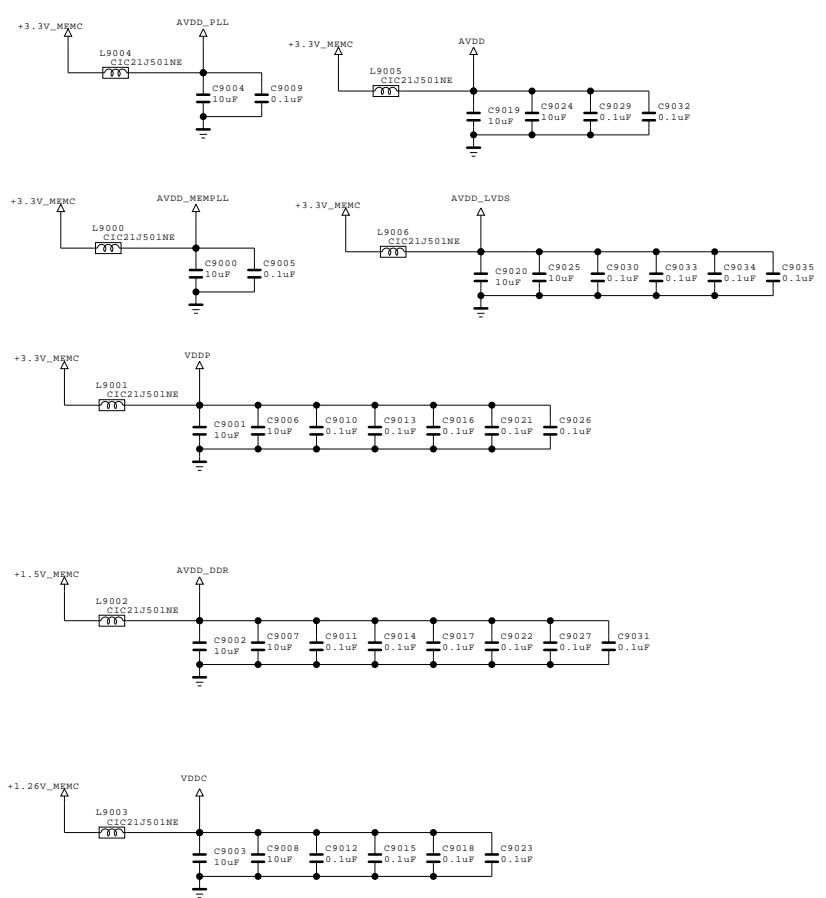

IC9001  
LGE7378A [FRC\_TCON\_URSA3]  
URSA3

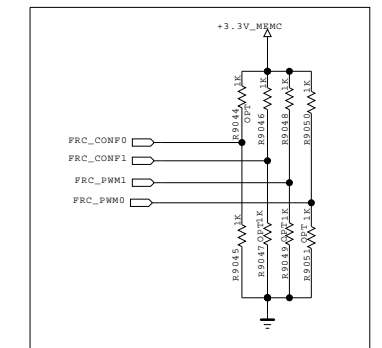

I2C ADR: GPIO1: HI:B8 LOW:B4  
CHIP\_CONF: {GPIO8, PWM1, PWM0}  
CHIP\_CONF= 3 : c5: boot from internal SRAM  
CHIP\_CONF= 3 : c6: boot from EPROM  
CHIP\_CONF= 3 : c7: boot from SPI Flash

Separate DVDD\_DDR Power

THE  $\Delta$  SYMBOL MARK OF THIS SCHEMATIC DIAGRAM INCORPORATES SPECIAL FEATURES IMPORTANT FOR PROTECTION FROM X-RADIATION. FILRE AND ELECTRICAL SHOCK HAZARDS, WHEN SERVICING IF IS ESSENTIAL THAT ONLY MANUFACTURES SPECIFIED PARTS BE USED FOR THE CRITICAL COMPONENTS IN THE  $\Delta$  SYMBOL MARK OF THE SCHEMATIC.

SECRET  
LGElectronics



MODEL BLOCK	COMMON	DATE SHEET	2009.09.11
	URSA3 (NO L.D.)		90

[LEVEL Shift Block]

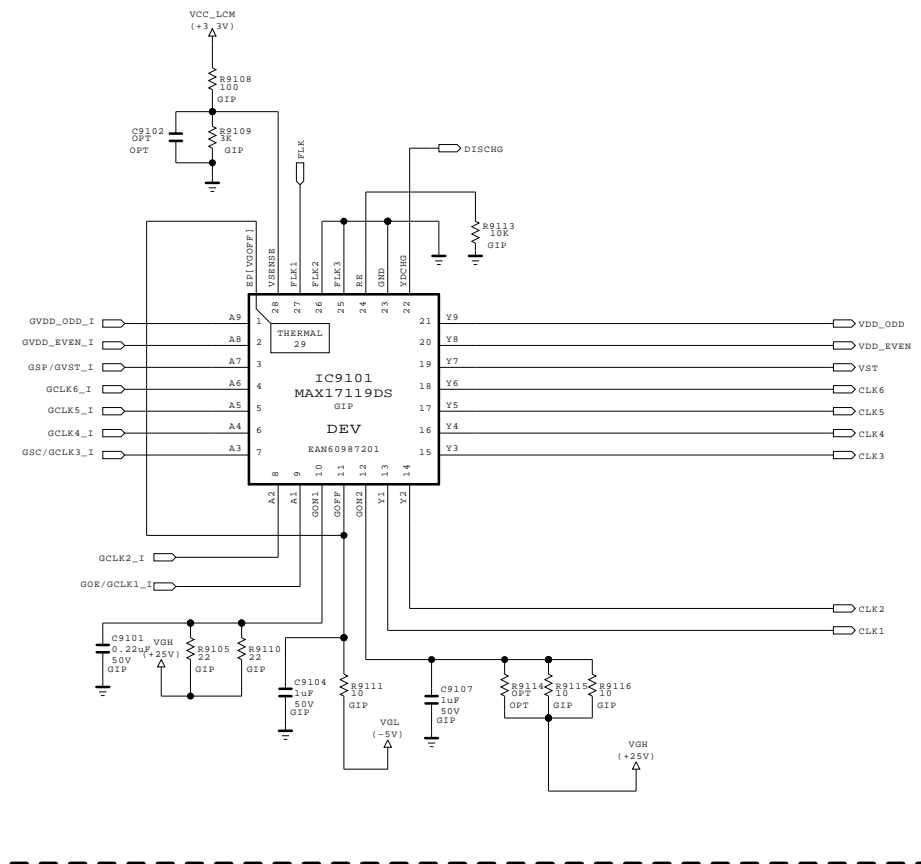

[POWER Block]

\* Voltage Target  
 VDD\_LCM = 16.25V  
 VGH = 28.50V  
 VGL = -5.35V

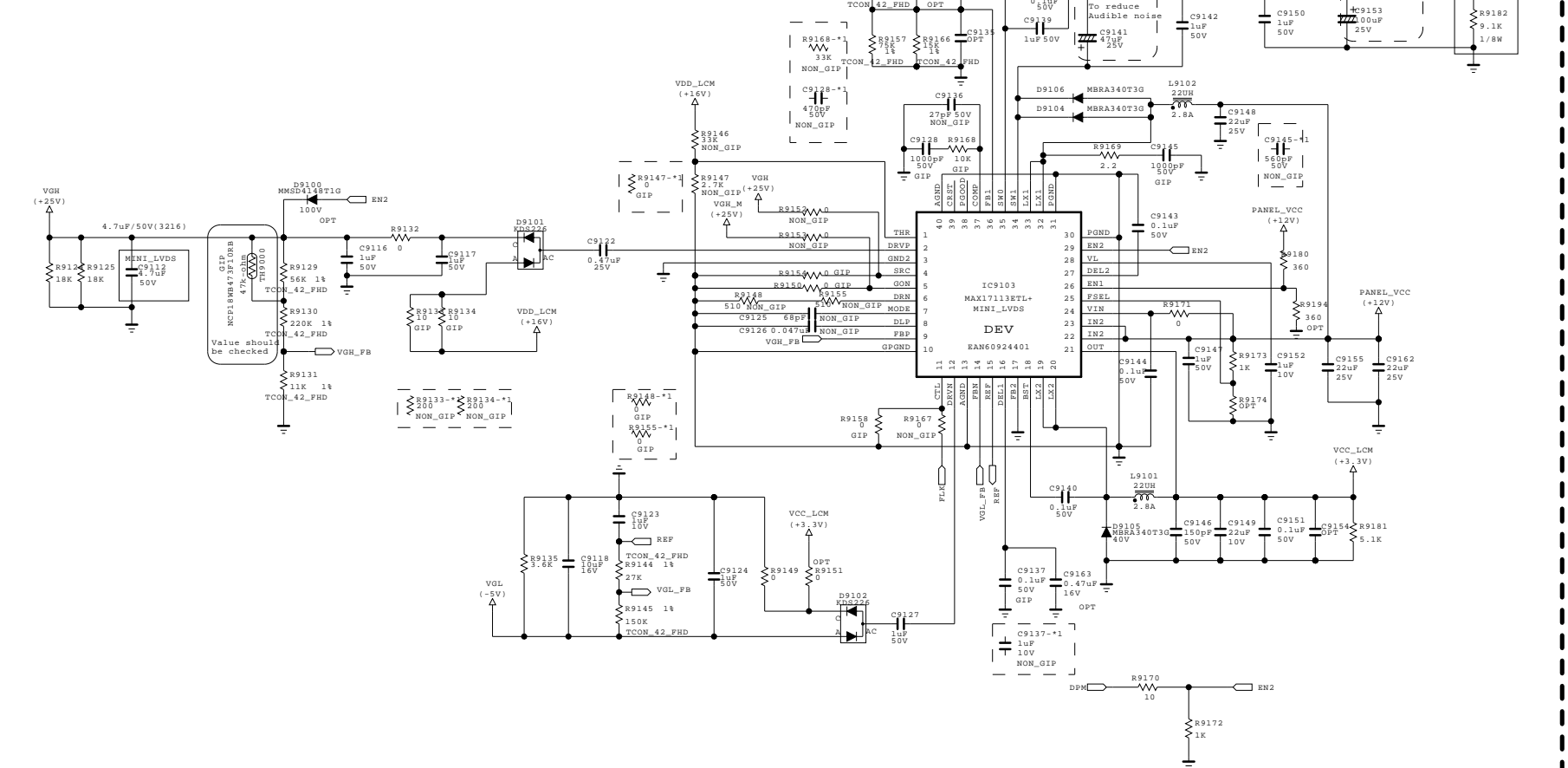

[P-GAMMA Block]

Slave Address : 0xE8h  
 (AO Pin - GND)

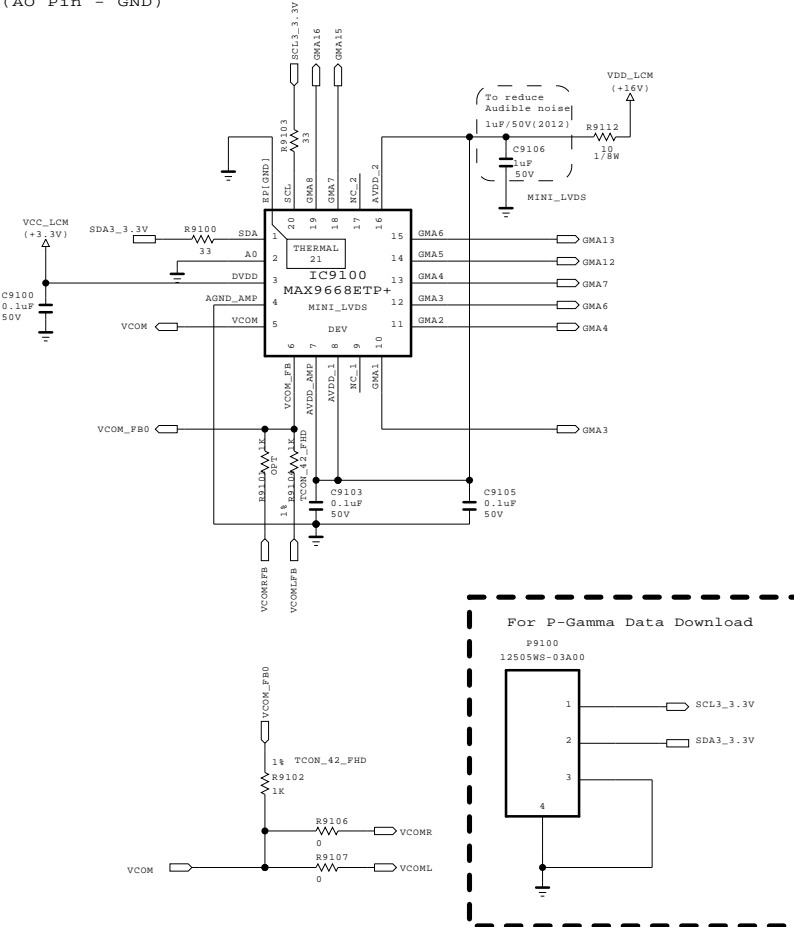

[HVDD Block]

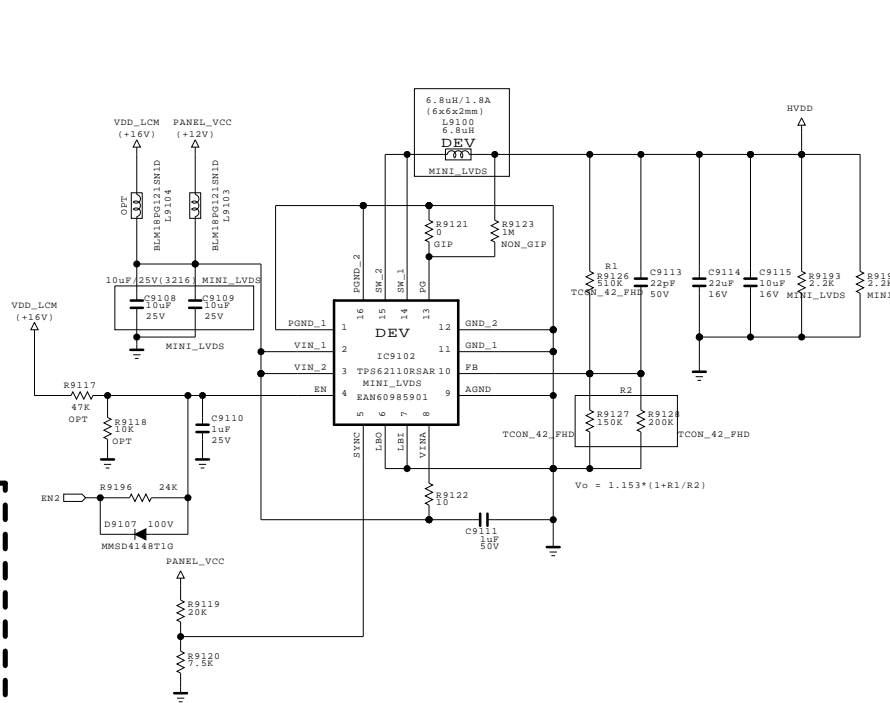

(Signal Name Change)

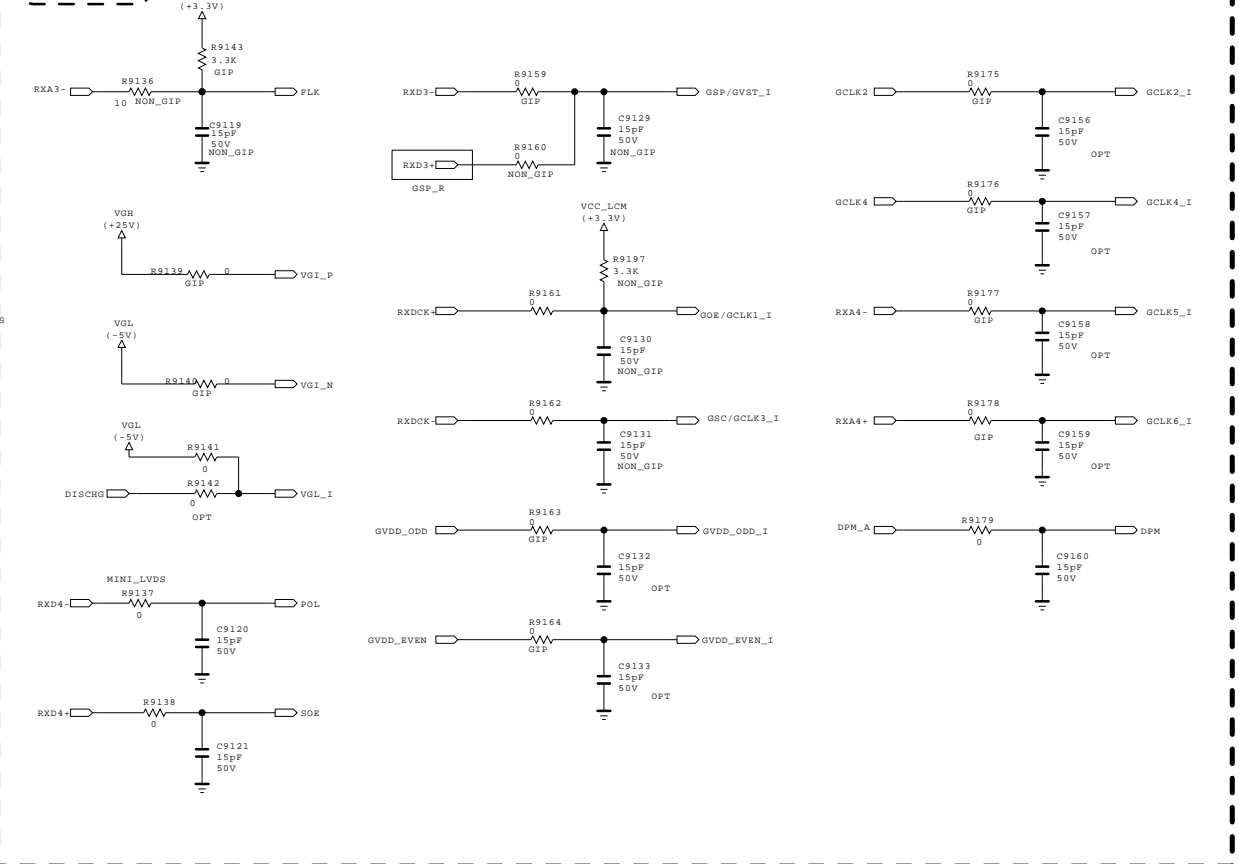

THE  $\Delta$  SYMBOL MARK OF THIS SCHEMATIC DIAGRAM INCORPORATES SPECIAL FEATURES IMPORTANT FOR PROTECTION FROM X-RADIATION. FILRE AND ELECTRICAL SHOCK HAZARDS, WHEN SERVICING IF IS ESSENTIAL THAT ONLY MANUFACTURES SPECIFIED PARTS BE USED FOR THE CRITICAL COMPONENTS IN THE  $\Delta$  SYMBOL MARK OF THE SCHEMATIC.

SECRET  
 LGElectronics



MODEL BLOCK	COMMON	DATE SHEET	09/09/10
	T-Con (NO L.D.)		91

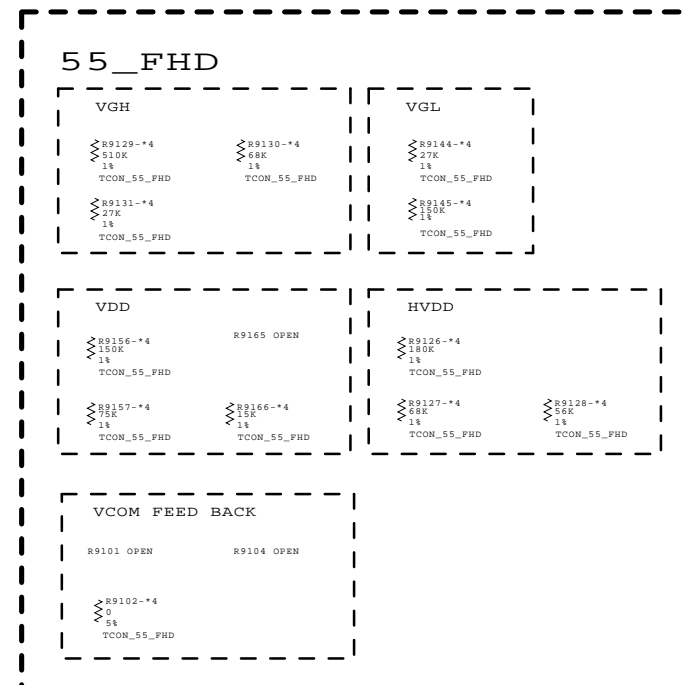
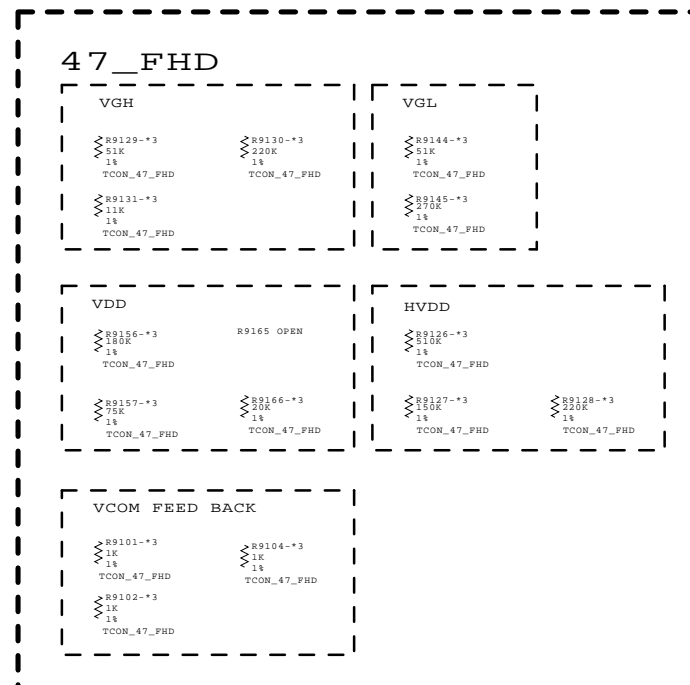
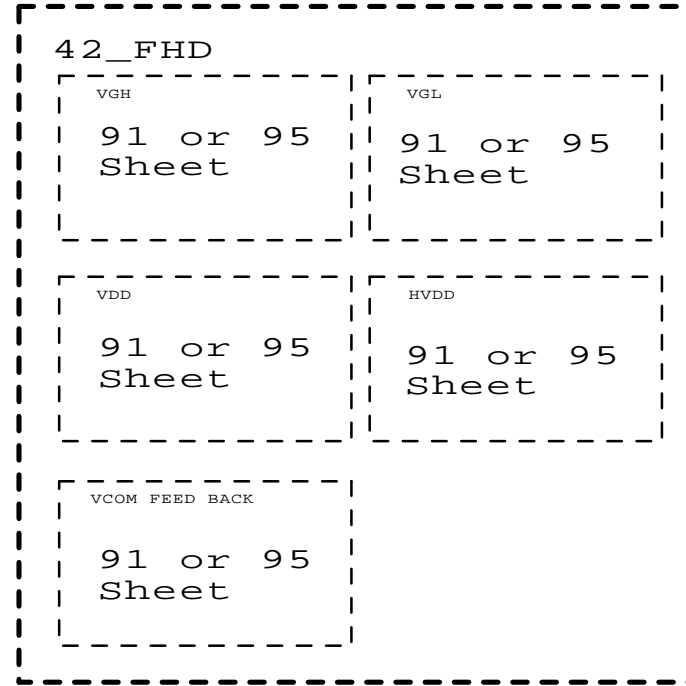
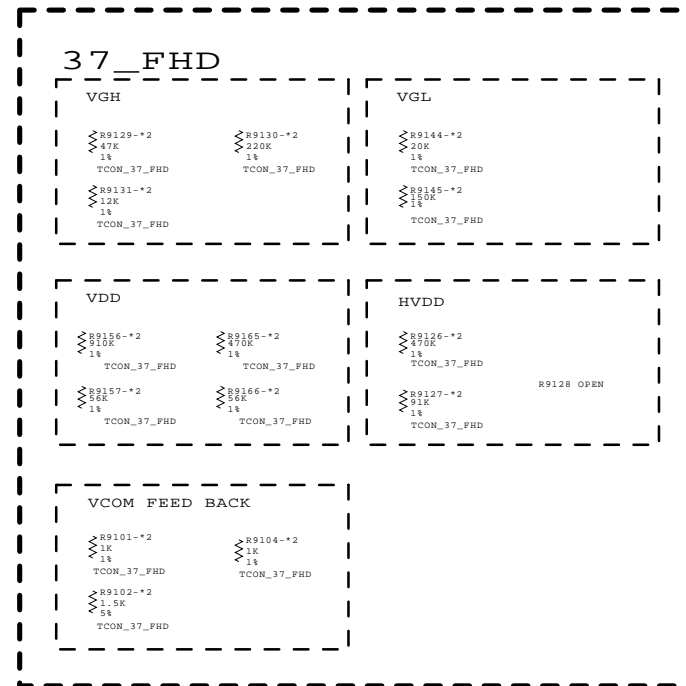
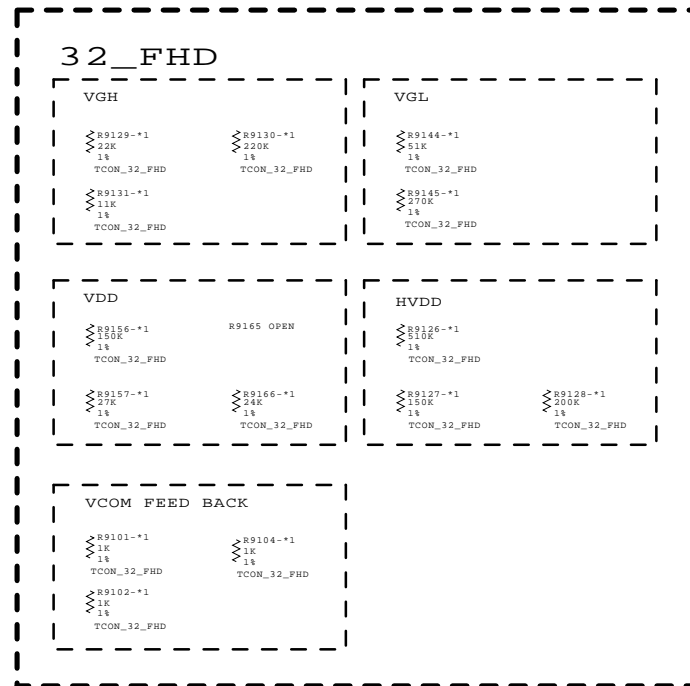

THE  $\Delta$  SYMBOL MARK OF THIS SCHEMATIC DIAGRAM INCORPORATES SPECIAL FEATURES IMPORTANT FOR PROTECTION FROM X-RADIATION, FILRE AND ELECTRICAL SHOCK HAZARDS, WHEN SERVICING IF IS ESSENTIAL THAT ONLY MANUFACTURES SPECIFIED PARTS BE USED FOR THE CRITICAL COMPONENTS IN THE  $\Delta$  SYMBOL MARK OF THE SCHEMATIC.

SECRET  
LGElectronics



MODEL	Common	DATE	09/12/15
BLOCK	T-Con Power Option	SHEET	98 /



# BCM High Block Diagram (Input/Interface)

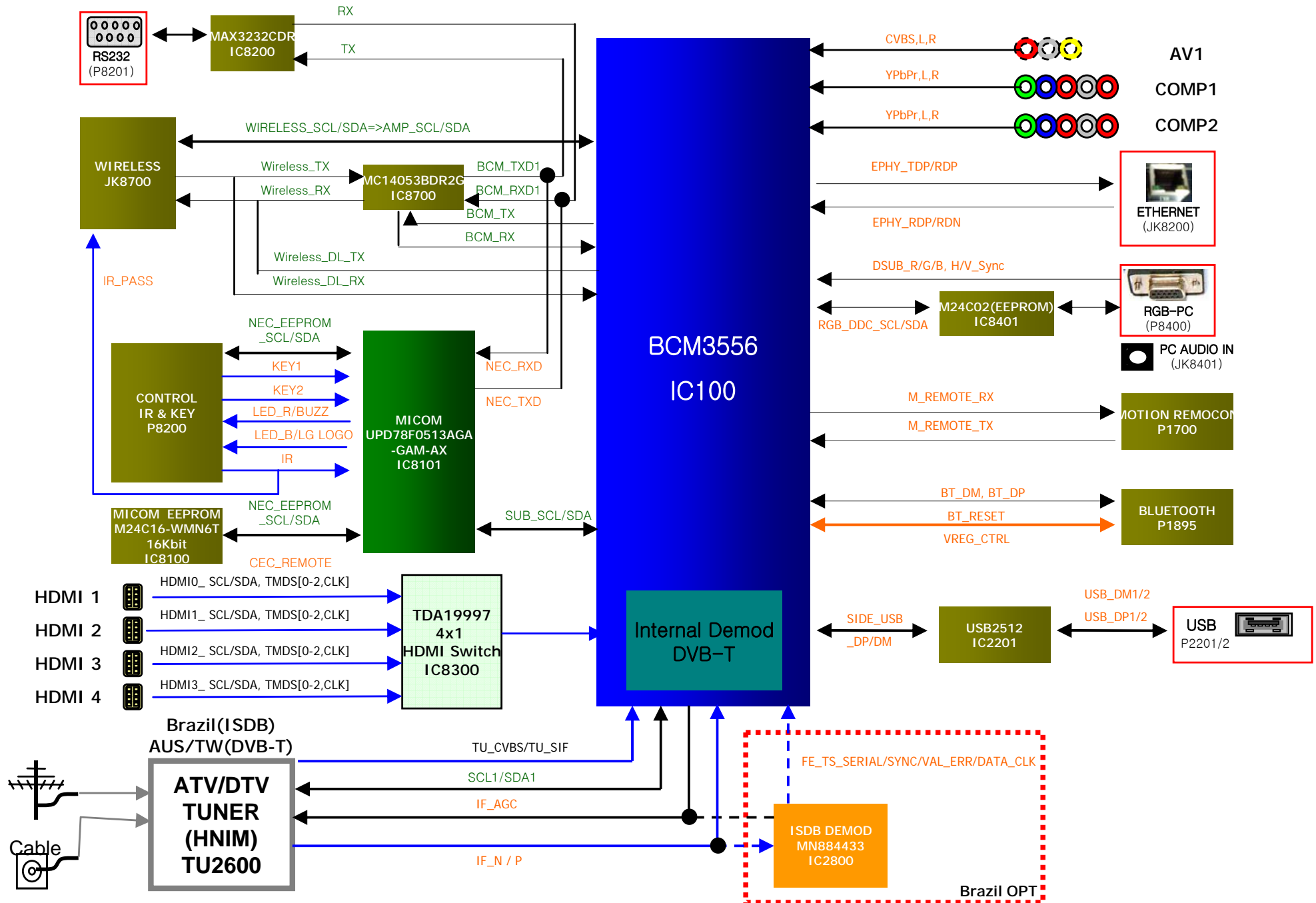

# BCM High Block Diagram (Output/Audio)

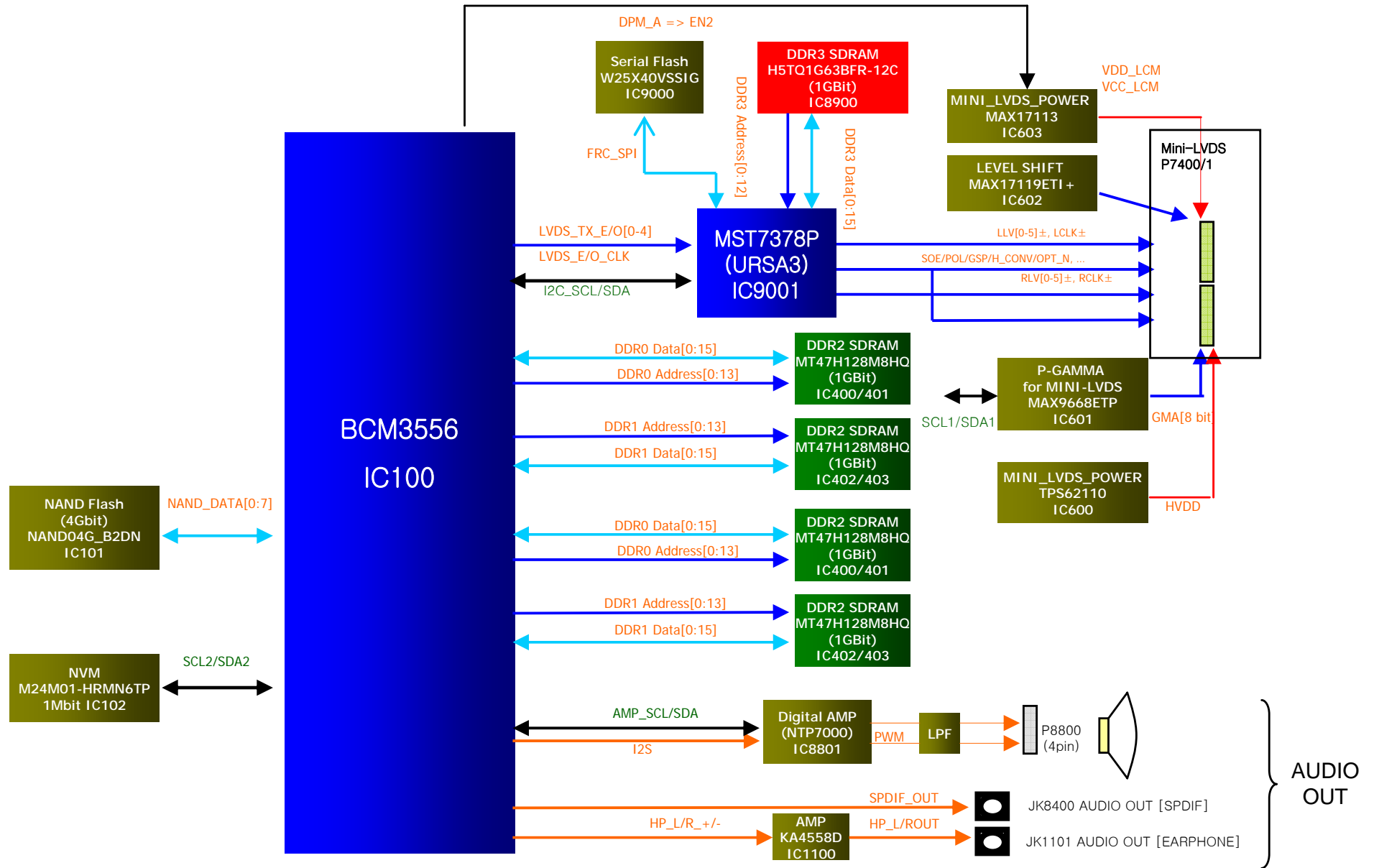

# BCM High Block Diagram (Memory)

