

## General Information

**Also Covers:**  
**DVT-1484D, DVT-2084D**

**Ferguson**  
**FG 14 CB 12V, FG 20 CB 12V**

**Goodmans**  
**TVC 1400 & TVC 14 VP**

## Electrical Adjustments (TV)

### GENERAL INFORMATION

All adjustments are thoroughly checked and corrected when the receiver leaves the factory. Therefore the receiver should operate normally and produce proper colour and B/W pictures upon installation. But, several minor adjustments may be required depending on the particular location in which the receiver is operated. This receiver is shipped completely in a card-board carton. Carefully draw out the receiver from the carton and remove all packing materials.

Plug the power cord into a AC power outlet. Turn the receiver ON and adjust the FINE TUNING for the best picture detail. Check and adjust all the customer controls such as BRIGHTNESS, CONTRAST and COLOUR Controls to obtain a natural B/W picture.

### PROTECTION CIRCUIT CHECK

1. Turn on the receiver.
2. The receiver must be turned off and changed in stand-by mode.

### HIGH VOLTAGE CHECK

1. Connect an accurate high voltage metre to the anode of the picture tube.
2. Turn on the receiver. Set the BRIGHTNESS and CONTRAST controls to minimize (zero beam current).
3. High voltage should be below 27.5kv (14:25.0kv, 21": 29.0kv)

### AUTOMATIC DEGAUSSING

A degaussing coil is mounted around the picture tube so that external degaussing after moving the receiver is normally unnecessary. Providing the receiver is properly degaussed upon installation. The degaussing coil operates for about 1 second after the power of the receiver is switched ON. If the set is moved or placed in a different direction, the power switch must be switched off for at least 15 minutes in order to make the automatic degaussing circuit operate properly.

Should the chassis or parts of the cabinet become magnetized to cause poor colour purity, use an external degaussing coil. Slowly move the degaussing coil around the faceplate of the picture tube, the sides and front of the receiver and slowly withdraw the coil to a distance of about 2m before disconnecting it from the AC source.

If colour shading still persists, perform the COLOUR PURITY ADJUSTMENT and CONVERGENCE ADJUSTMENTS procedures, as mentioned later.

### DYNAMIC CONVERGENCE ADJUSTMENT

Dynamic convergence (convergence of the three colour field at the edges of the CRT screen) is accomplished by proper insertion and positioning of three rubber wedges between the edges of the deflection yoke and the funnel of

the CRT. This is accomplished as follows:

1. Switch the receiver on allow it to warm up for 15 minutes.
2. Apply crosshatch pattern from dot/bar generator to the receiver. Observe spacing between lines around edges of the CRT screen.
3. Tilt the deflection yoke up and down, and insert tilt adjustment wedges 1 and 2 between the deflection yoke and the CRT until the mis-convergence illustrated in figure. 2 (A) has been corrected.
4. Tilt the deflection yoke right and left, and insert tilt adjustment wedge 3 between the deflection yoke and the CRT until mis-convergence illustrated in figure. 2 (B) has been corrected.
5. Alternately change spacing between, and depth of the insertion of, the three wedges until proper dynamic convergence is obtained.
6. Use a strong adhesive tape to firmly secure latch of the three rubber wedges to the funnel of the CRT.
7. Check purity and readjust, if necessary.

### STATIC (CENTRE) CONVERGENCE ADJUSTMENT

1. Switch the receiver on and allow it to warm up for 15 minutes.
2. Connect the output of a crosshatch generator to the receiver and concentrating on the centre of the CRT screen, proceed as follows:
  - a. Locate the pair of 4 pole magnet rings. Rotate individual rings (Change spacing between tabs) to converge the vertical red and blue lines. Rotate the pair of rings (maintaining spacing between tabs) to converge the horizontal red and blue lines. (Refer to fig. 1 (A))
  - b. After completing red and blue centre convergence, locate the pair of 6 pole magnet rings. Rotate individual rings (change spacing between tabs) to converge the vertical red and blue (Magenta) and green lines. Rotate the pair of rings (maintaining spacing between tabs) to converge the horizontal red and blue (Magenta) and green lines. (Refer to Fig. 1(B))

### COLOR PURITY ADJUSTMENT

For the best result, it is recommended that the purity adjustment is made in final receiver location. If the receiver will be moved, perform adjustment with it's facing east. The receiver must have been operating 15 minutes prior to this procedure and the faceplate of the CRT must be at room temperature. The receiver is equipped with an automatic degaussing circuit. But, if the CRT shadow mask has come excessively magnetized, it may be necessary to degauss it with manual coil. Do not switch the coil.

The following procedure is recommended while using a dot generation.

1. Check for correct location of all neck components (See figure. 5).
2. Rough-in the static convergence at the centre of the CRT, as explained in the static convergence procedure.
3. Rotate the picture control to centre of its rotation range, and rotate brightness control to max. CW position.
4. Apply green color signal to procedure a green raster.
5. Loosen the deflection yoke tilt adjustment wedges (3), loosen the deflection yoke clamp screw and push the deflection yoke as close as possible to the CRT screen.
6. Begin the following adjustment with the tabs on the round purity magnet rings set together, initially move the tabs on the round purity magnet rings to the side of the CRT neck. Then, slowly separate the two tabs while at the same time rotating them to adjust for a uniform green vertical band at the CRT screen.
7. Carefully side the deflection yoke backward to achieve green purity. (uniform green screen) Centre purity was obtained by adjusting the tabs on the round purity magnet rings, outer edge purity was obtained by sliding the deflection yoke forward. Tighten the deflection yoke clamp screw.
8. Check for red and blue field purity by applying red signal and touch up adjustments, if required.
9. Perform black and white tracking procedure.

### SCREEN & WHITE BALANCE ADJUSTMENT

1. This adjustment is to be made only after warming up at least 15 minutes.
2. Receive B/W pattern signal
3. Set the RGB Bias VR (R522, R512, R502) to center.
4. Set the G, B Drive VR (R515, R505) to CENTER.
5. Set the CONTRAST, BRIGHTNESS, COLOR control to MIN, and Sub-brightness control to CENTER.
6. Rotate the R, G and B Bias VR of the other color which did not appear on the screen clockwise, until a dim white is obtained.
7. Rotate the Screen control gradually anti-clockwise until the last horizontal line disappears on the screen.
8. Set the CONTRAST, BRIGHTNESS, COLOR control to MAX.
9. Set the G, B Drive VR to obtain the best white uniformity on the screen.
10. Rotate the CONTRAST, BRIGHTNESS, COLOR controls until a dim raster is obtained and touch-up adjustment of RGB Bias VR to obtain the best white uniformity on the screen.

### SUB-BRIGHTNESS ADJUSTMENT

1. White balance adjustment must proceed this procedure.
2. Set the CONTRAST, BRIGHTNESS, COLOR control to MIN.
3. Rotate the SUB-BRIGHTNESS VR (VRA01) gradually CCW until the last beam disappears on the screen.

### VERTICAL HEIGHT ADJUSTMENT

1. Receive RETMA pattern signal.
2. Set the BRIGHTNESS control and CONTRAST control to Max., and the COLOR control to centre.
3. Adjust VR301 for the optimum vertical height and over scanning.

### VERTICAL CENTER ADJUSTMENT

1. Receive RETMA pattern signal.
2. Adjust VR302 so that the vertical center of the picture may be coincident with the mechanical center of CRT.

### HORIZONTAL CENTER ADJUSTMENT

1. Receive RETMA pattern signal.

2. Adjust VR401 so that the horizontal centre of the picture may be coincident with the mechanical centre of CRT.

### FOCUS VOLTAGE ADJUSTMENT

1. Receive RETMA pattern signal.
2. Adjust the FOCUS VOLUME on the FBT and make the picture on the screen be finest.

### RF AGC ADJUSTMENT

1. Receive PAL COLOR BAR signal in the VHF high band where the strength of signal can be 60-65 dB.
2. Set the CONTRAST control to Max., the BRIGHTNESS control to provide adequate black and grey scales.
3. Maintain the fine tuning on the screen, and adjust VR601 (AGC DELAY CONTROL VR.) in order that it may be located on the position which the picture noise disappear on the image.

### MAIN B+ (+103V) ADJUSTMENT

1. Set the Bright, Contrast and colour to MAX.
2. Connect DC voltage meter to the P405 and adjust VR801 for +103V DC.

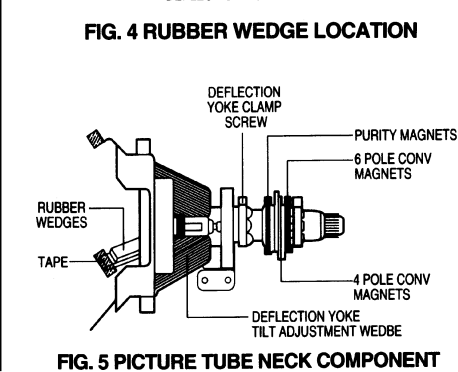
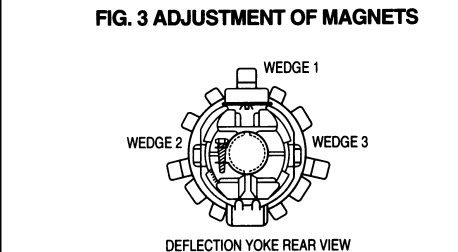
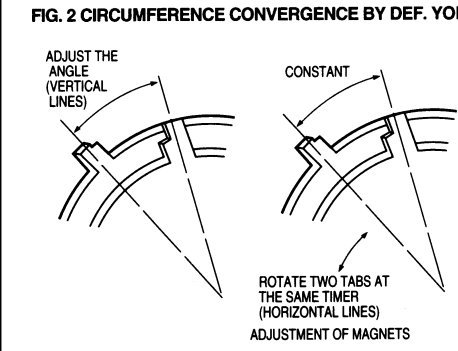
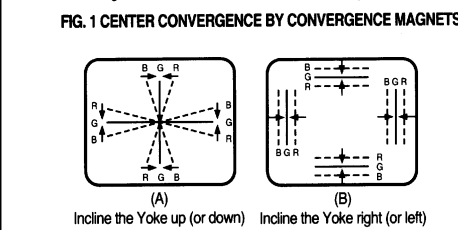
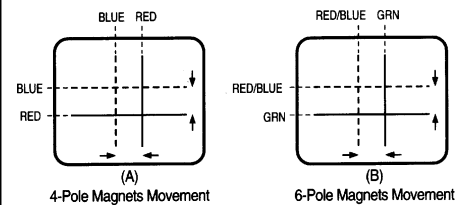

### PIF ADJUSTMENT

#### 1. APPARATUS CONNECTION & PRESETTING

#### CONNECTION

1. Connect H-out of LSW-480 to X-axis of the oscilloscope and V-out of LSW-480 to Y-axis of the oscilloscope.
2. Connect the sweep signal output to TP1.
3. Set ATTENUATOR of LSW-480 to 30dB.
4. Supply 12V D.C. voltage (B+) to TP4.
5. Supply 4-5V D.C. voltage to TP3.

#### PRESET

- a) Oscilloscope Scaling  
Put the scale of X and Y of the oscilloscope to D.C level.
- b) Set the horizontal time display to X-Y  
Put the horizontal axis (X) to 1V/div. and the vertical axis (Y) to 2V/div.

#### 2) LSW-480 MARKER FREQ. SETTING.

	fp(n+1)	fs	fc	fp-2	fp	fs(n-1)
B/G, D/K, L	31.9	33.4	34.5	36.9	38.9	40.4
	31.9	33.5	35.07	37.5	39.5	41

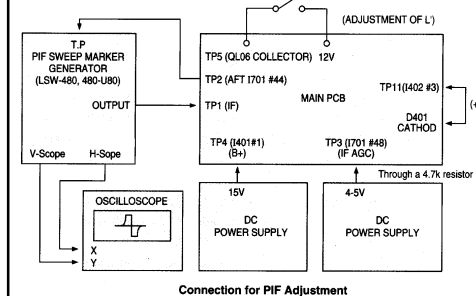

#### II. ADJUSTMENT OF AFT(B/G, D/K, I, L)

1. Connect the test point of LSW-480 to TP2.
2. Adjust L103 (AFT COIL) so that the P marker point is located on the reference level.

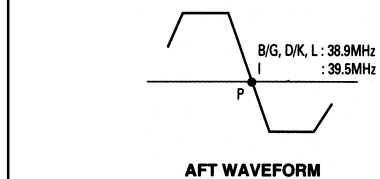

## Electrical Adjustments (VCR)

### ALIGNMENT AND ELECTRICAL ADJUSTMENT

For these adjustment, use the equipment mentioned below. The suitable output waveform of the color-bar signal and proceed by using the alignment tape and video signal. generator is shown below.

#### Instrument and Tools Required

1. Color TV receiver.
2. Oscilloscope having 10 MHz or more bandwidth.
3. Color-bar generator.
4. Frequency counter.
5. VTVM.
6. VOM (20 k $\Omega$ /V).
7. Audio oscillator.
8. Audio attenuator.

#### Signal Level and Input and Output Impedance Requirement

1. Video input: Negative sync, 1 Vp-p standard composite video signal, 75 $\Omega$ .
2. Video output: Same as above.
3. Audio input: Line -5dBm 47K $\Omega$ .
4. Audio output: -5dBm, 10K $\Omega$ . or less.

### Adjustment Sequence

The VCR should be adjusted in the sequence shown below.

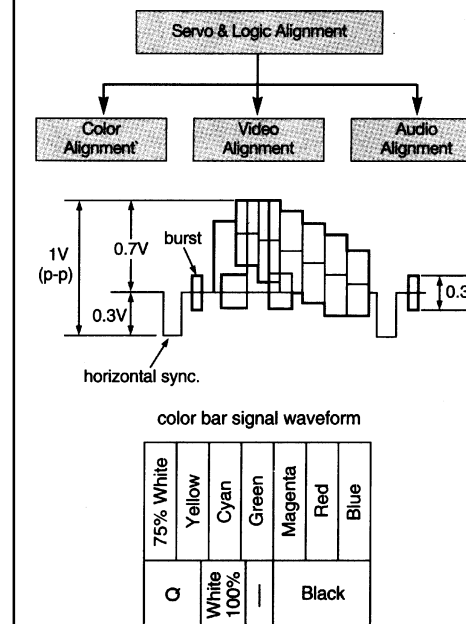

### SERVO

#### 1. PLAYBACK PHASE

Mode	Play
Adjustment Parts	R595
Check Point	TP396
Test Equipments	Oscilloscope
Test Tape	DP-1

#### Location of Adjustments Parts

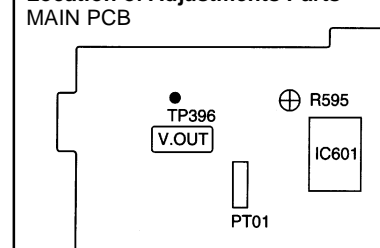

#### Observation Waveform

Horizontal Axis: S/DIV  
 Vertical Axis: CH1: SW30, CH2: V.OUT

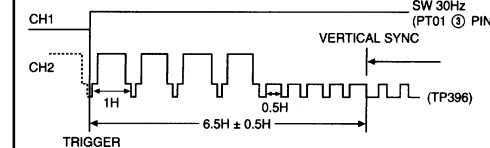

#### Adjustment Procedure

1. Preparation  
 1) Play back on test tape (COLOR BAR).  
 2) Set the oscilloscope to the CHOP mode. Connect CH1 to the SW PULSE (PT01 (3)) and CH2 to the VIDEO OUT (TP396) and trigger the scope with the signal from CH1.
2. Adjustment  
 1) Adjust R595 to position the rising edge of SW PULSE at 6.5H $\pm$ 0.5H from the V-SYNC.

### VIDEO

#### 1. EE LEVEL ADJUSTMENT

Mode	EE (Stop)
Adjustment Parts	R395
Check Point	TP395
Test Equipments	Oscilloscope Signal gen.
Input Signal	Color bar signal with 100% white

### Electrical Adjustments (VCR) Cont'd

#### Location of Adjustments Parts Main PCB

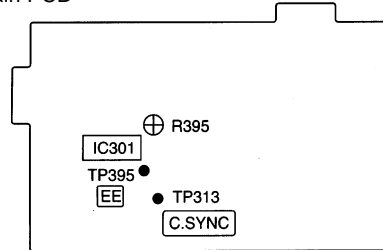

#### Observation Waveform

Horizontal Axis: 10μS/DIV  
Vertical Axis: 0.1 V/DIV

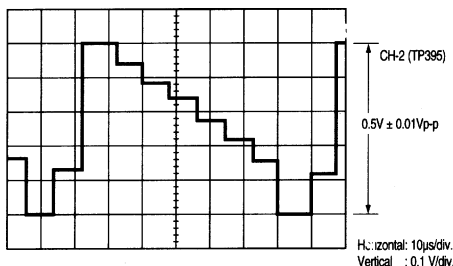

#### Adjustment Procedure

- Preparation
  - Set the LINE mode.
  - Supply the COLOR BAR signal with 100% white to the VIDEO IN JACK.
- Adjustment
  - Set the VCR to STOP (FE) mode.
  - Connect the oscilloscope to TP395 and trigger the scope externally with the composite synchronous signal from TP313.
  - Adjust R395 to obtain 0.5±0.01 Vp-p between the SYNC TIP and 100% white level.

#### 2. PLAYBACK OUTPUT LEVEL

Mode	PLAY
Adjustment Parts	R396
Check Point	TP396
Test Equipments	Oscilloscope
Test Tape	DP-1

#### Location of Adjustments Parts Main PCB

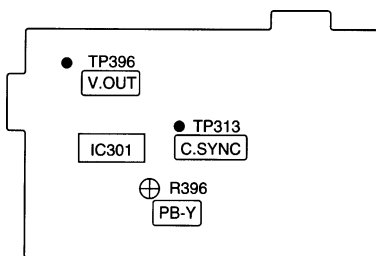

#### Observation Waveform

Horizontal Axis: S/DIV  
Vertical Axis: 0.5 V/DIV

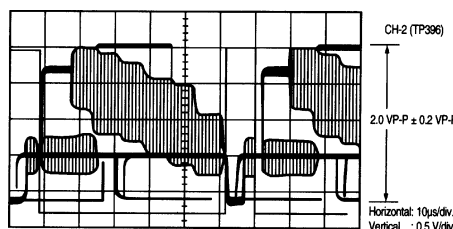

#### Adjustment Procedure

- Preparation
  - Set the SYSTEM SELECT SWITCH to the AUTO MODE.
  - Play back the test tape (COLOR BAR).
- Adjustment
  - Connect the oscilloscope to TP396 and trigger the scope externally with the C.SYNC signal from TP313.
  - Adjust R396 to obtain 2.0±0.1 Vp-p between the SYNC TIP and 100% white level.

#### 3. SYNC TIP FREQUENCY

Mode	(STOP)
Adjustment Parts	R391, R393
Check Point	TP391
Test Equipments	Frequency counter
Input Signal	No signal

#### Location of Adjustments Parts Main PCB

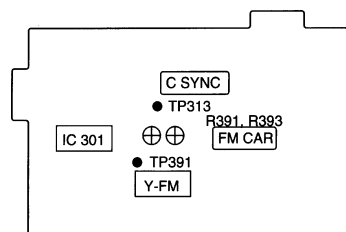

#### Adjustment Procedure

- Preparation
  - Set the LINE mode.
  - Supply the input signal in the OPEN state.
- Adjustment
  - Set the VCR to the FE (STOP) mode.
  - Connect the frequency counter to TP391.
  - Set the SYSTEM SELECT SWITCH to the PAL mode.
  - Adjust R393 to obtain 3.8 ± 0.1 Mhz.

#### 4. FM DEVIATION

Mode	REC PLAY
Adjustment Parts	R392
Check Point	TP396
Test Equipments	Oscilloscope
Input Signal	Color bar with 100% white

#### Location of Adjustments Parts Main PCB

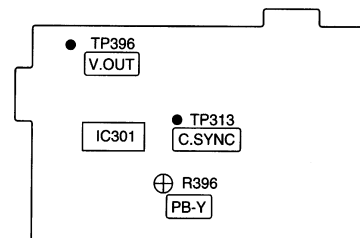

#### Observation Waveform

Horizontal Axis: 10μS/DIV  
Vertical Axis: 0.5V/DIV

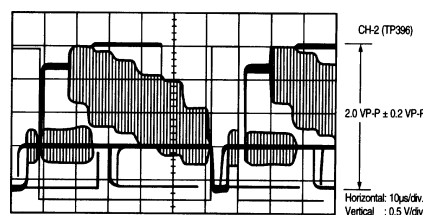

#### Adjustment Procedure

- Preparation
  - Set the LINE mode.
  - Supply the COLOR BAR signal to the VIDEO IN JACK.
- Adjustment
  - Connect the oscilloscope to TP396 (VOUT) and trigger the scope externally with the C.SYNC signal from TP313.
  - Record the signal for about 10 seconds in SP mode and play back the signal just recorded. Confirm the playback output level is 2.0±0.2Vp-p.

#### 2. Adjustment

- If the playback output level is not 2.0±0.2Vp-p, adjust as follows.
- Adjust R392 a little.
  - Record the Color bar signal for about 10 seconds and play back the signal just recorded.
  - Confirm the playback output level.
  - Repeat the procedure 1) to 4) until the playback output level becomes 2.0±0.2Vp-p between the SYNC TIP and 100% white peak.

#### 5. C RECORD CURRENT

Mode	EE
Adjustment Parts	R399 & R491
Check Point	TP399
Test Equipments	Oscilloscope
Test Tape	Blank Tape
Input Signal	Color Bar

#### Location of Adjustments Parts Main PCB

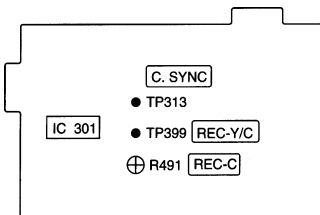

#### Observation Waveform

Horizontal Axis: 10μS/DIV  
Vertical Axis: 20 mV/DIV

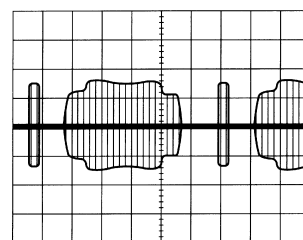

#### Adjustment Procedure

- Preparation
  - Set the LINE mode.
  - Supply the COLOR BAR signal to the VIDEO IN JACK.
- Adjustment
  - Set the VCR to FE mode.
  - Connect the oscilloscope to TP399. Adjust R399 until Y-FM record current becomes minimum.
  - Trigger the scope externally with the C.SYNC signal from TP313.
  - Adjust R491 until Color record current becomes 80±5 mVp-p.

#### 6. Y RECORD CURRENT

Mode	FE
Adjustment Parts	R399
Check Point	TP399
Test Equipments	Oscilloscope

Test Tape Input Signal  
Blank Tape Color Bar

#### Location of Adjustments Parts Main PCB

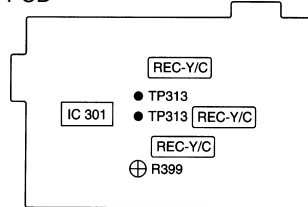

#### Observation Waveform

Horizontal Axis: 10μS/DIV  
Vertical Axis: 50 mV/DIV

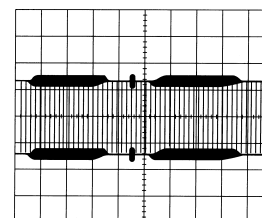

#### Adjustment Procedure

- Preparation
  - Set the LINE mode.
  - Supply the COLOR BAR signal to the VIDEO IN JACK.
- Adjustment
  - Set the VCR to the EE mode.
  - Trigger the scope externally with the C.SYNC signal from TP313.
  - Connect the oscilloscope to TP399. Adjust R399 until Y-FM record current becomes 300±10 mVp-p.

#### AUDIO

##### 1. AUDIO PLAYBACK OUTPUT LEVEL

Mode	Play
Adjustment Parts	R291
Check Point	Audio Output
Test Equipments	Audio Level Meter
Test Tape	DP-1

#### Location of Adjustments Parts Main PCB

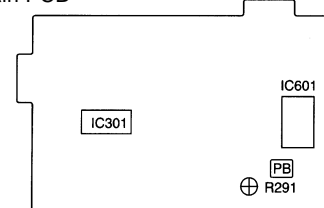

#### Adjustment Procedure

- Preparation
  - Connect the AUDIO level meter to the AUDIO OUTPUT JACK.
  - Play back the test tape (DP-1).
- Adjustment
  - Adjust R291 until the output level becomes -5 ± 1.5dBm.

##### 2. AUDIO RECORD BIAS

Mode	REC
Adjustment Parts	R292
Check Point	TP201, TP202
Test Equipments	Audio Level Meter
Test Tape	Blank Tape

#### Location of Adjustments Parts Main PCB

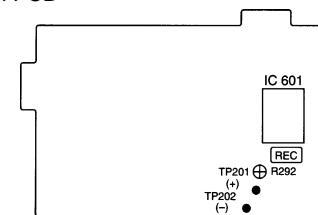

#### Adjustment Procedure

- Preparation
  - Set the LINE mode.
  - Supply the signal in OPEN mode.
  - Connect the AUDIO level meter to both TP201 and TP202.
  - After inserting a blank tape, record in SP mode.
- Adjustment
  - Adjust R292 to obtain 2.4mVrms.
- Adjustment Inspection Standard
 

In confirmation of recording playback frequency characteristics, compared with 1 KHz recording-playback output level, (8KHz) recording-playback output level is higher than the standard, increase the record bias and if lower, decrease it.

End

Video Diagram

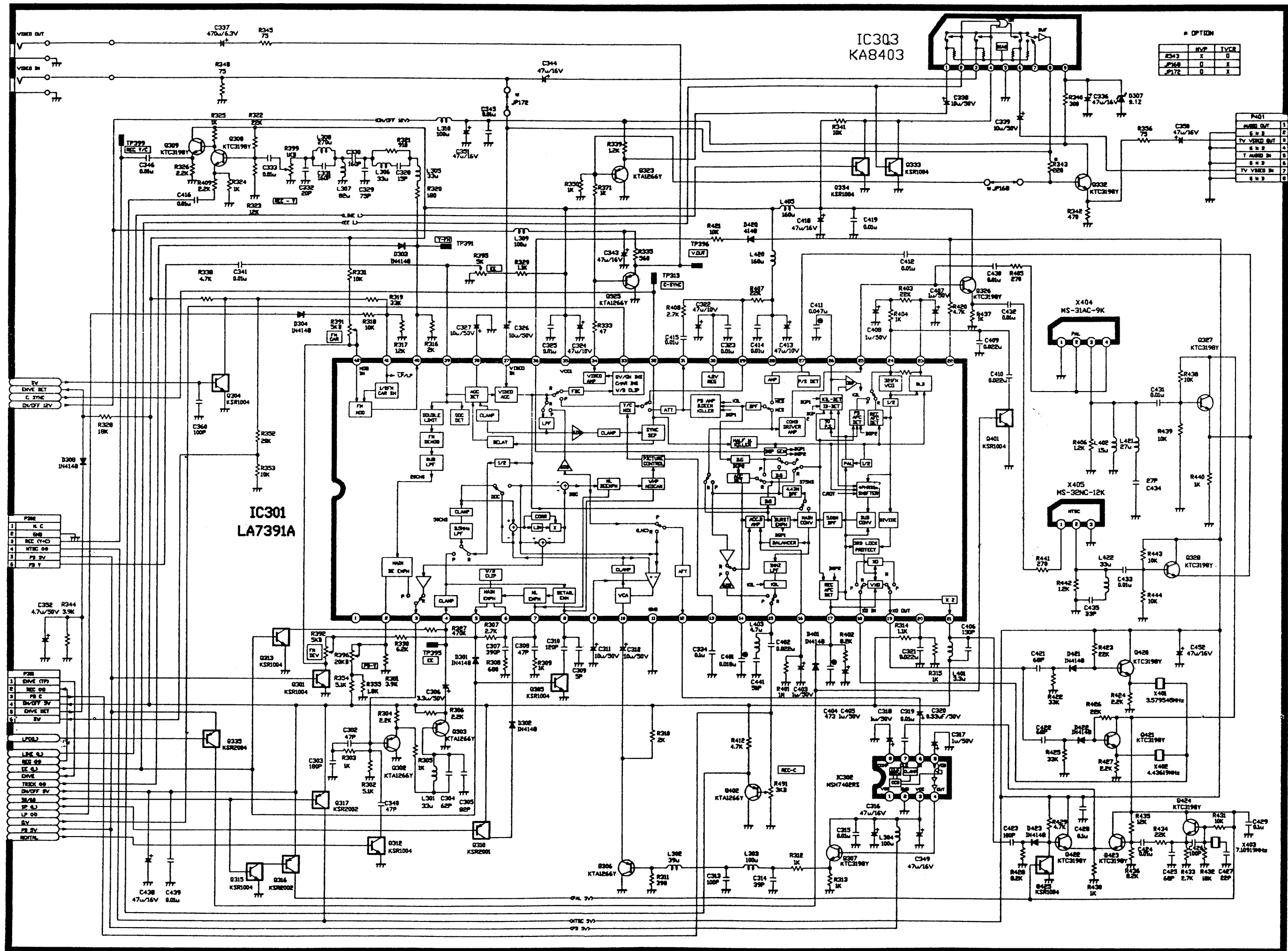

Audio Diagram

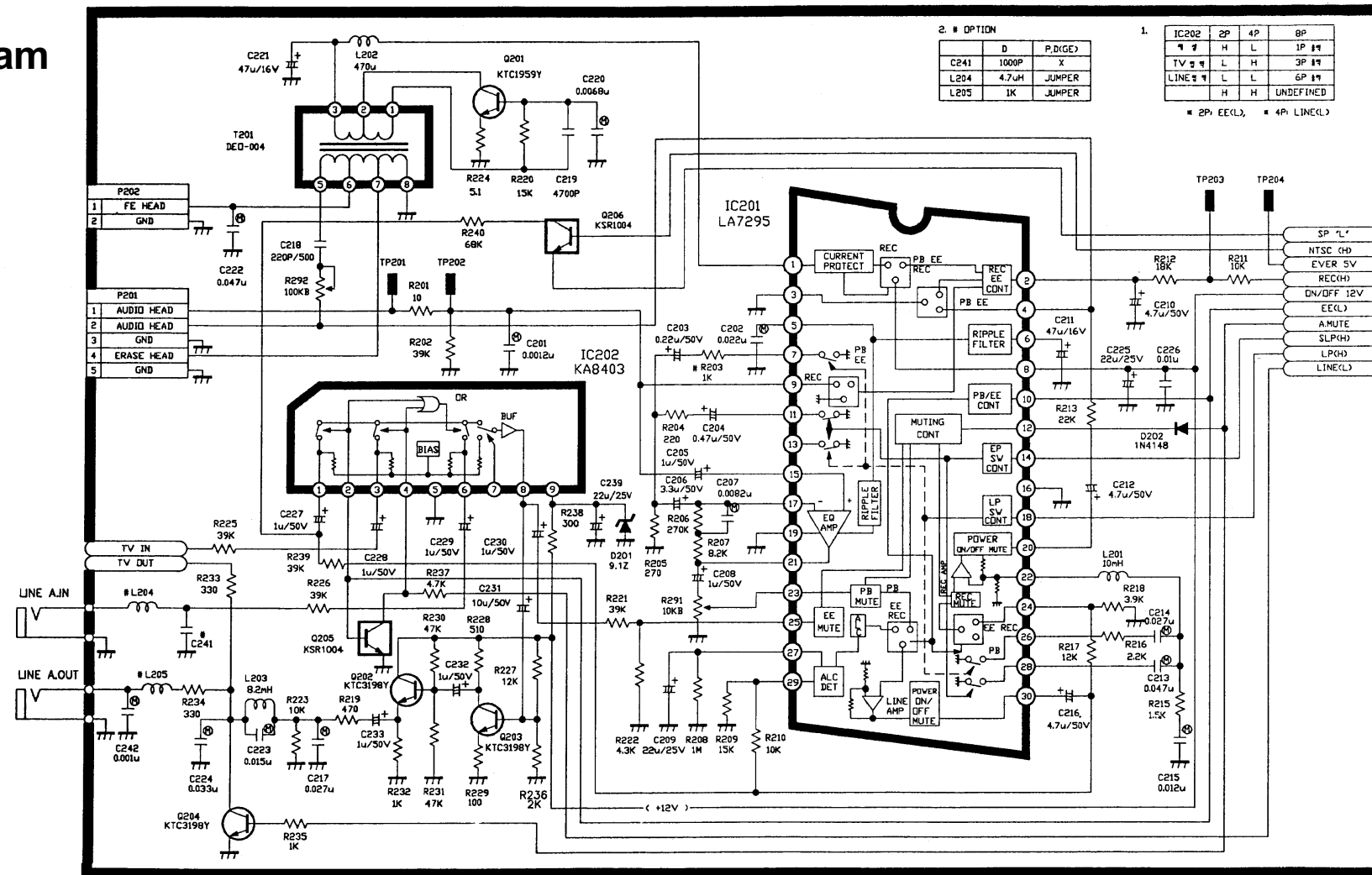

Remote Control Diagram

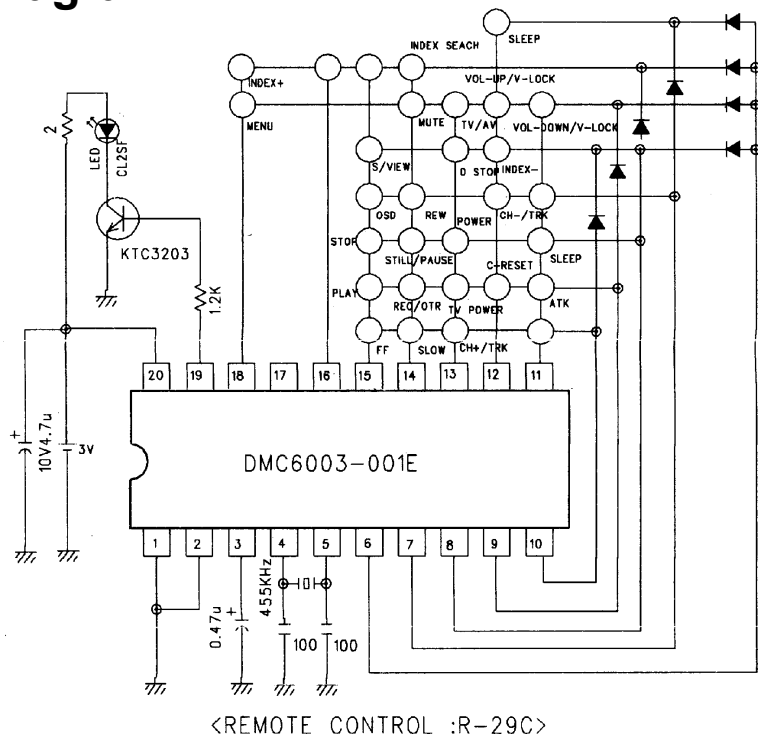

Head Amp Diagram

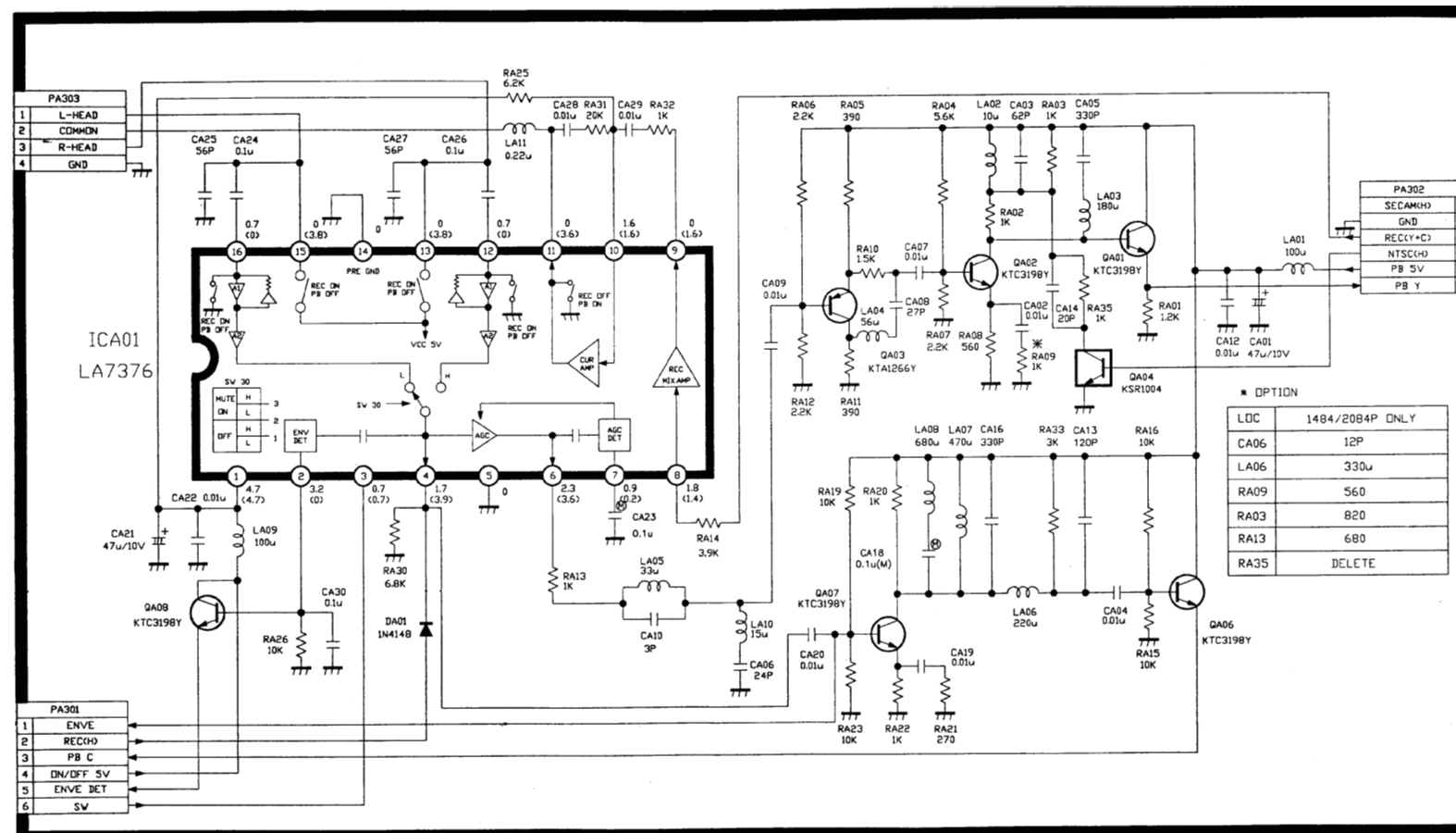

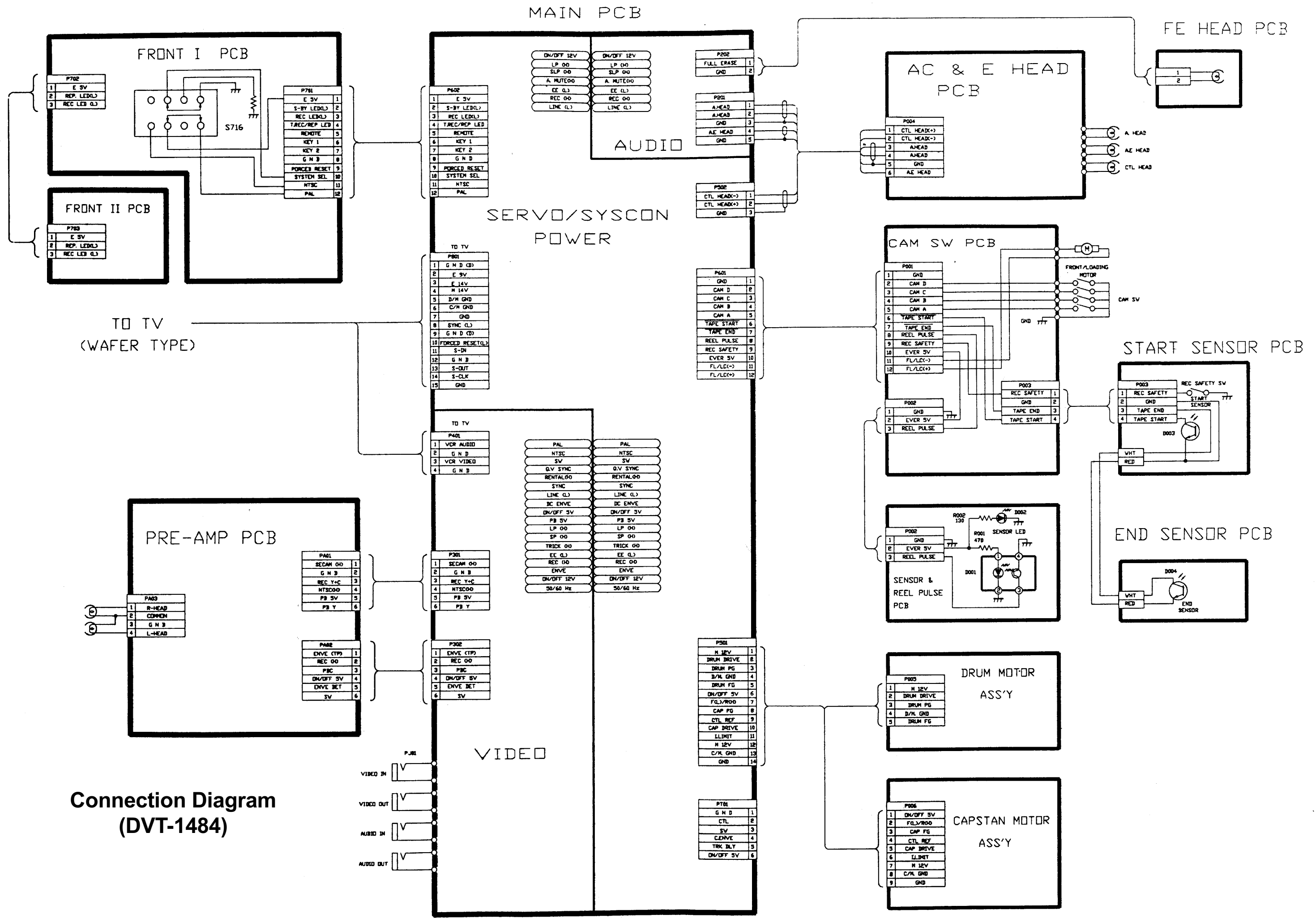

Connection Diagram (DVT-1484)

MAIN PCB

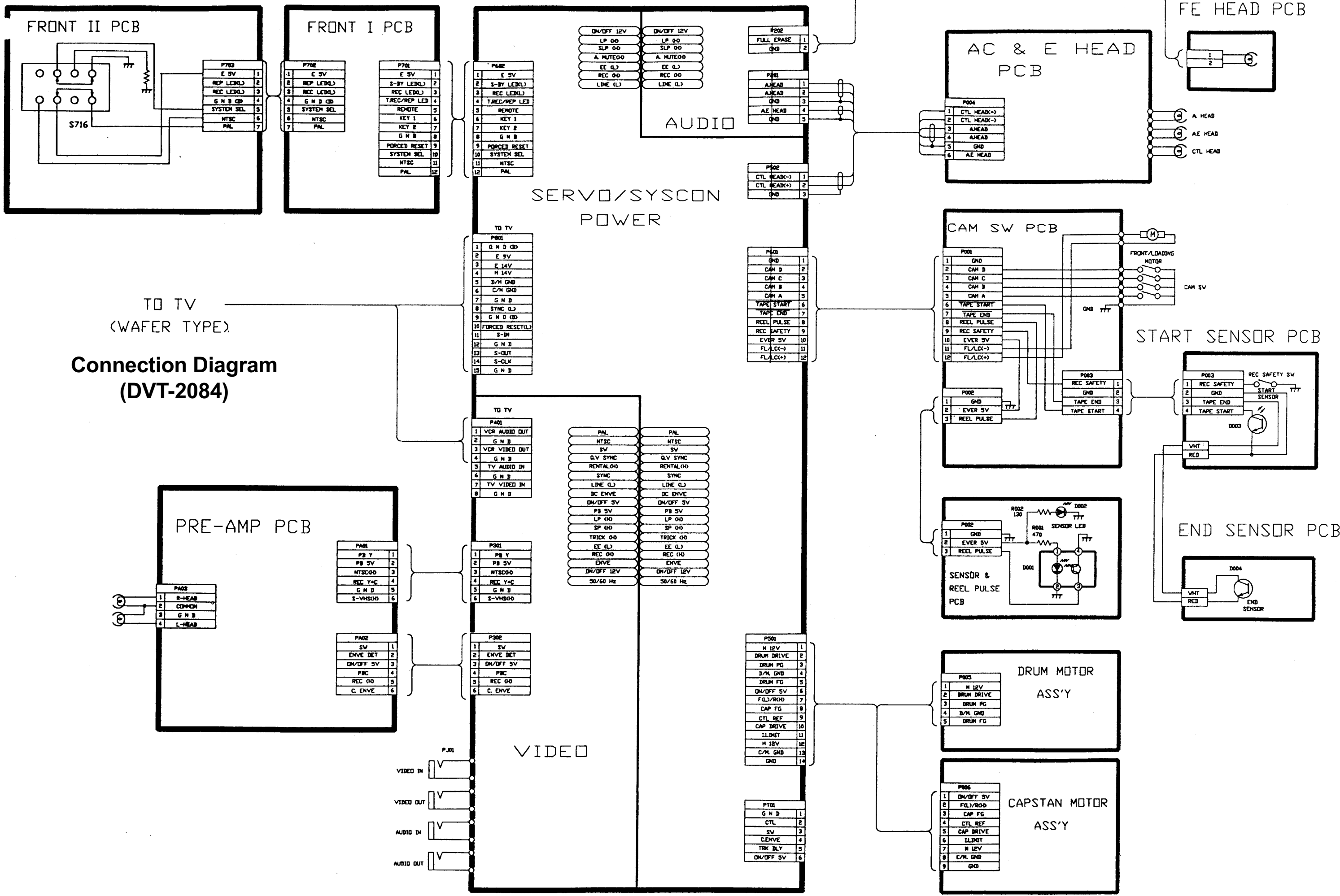

Connection Diagram (DVT-2084)

Main Diagram (TV)

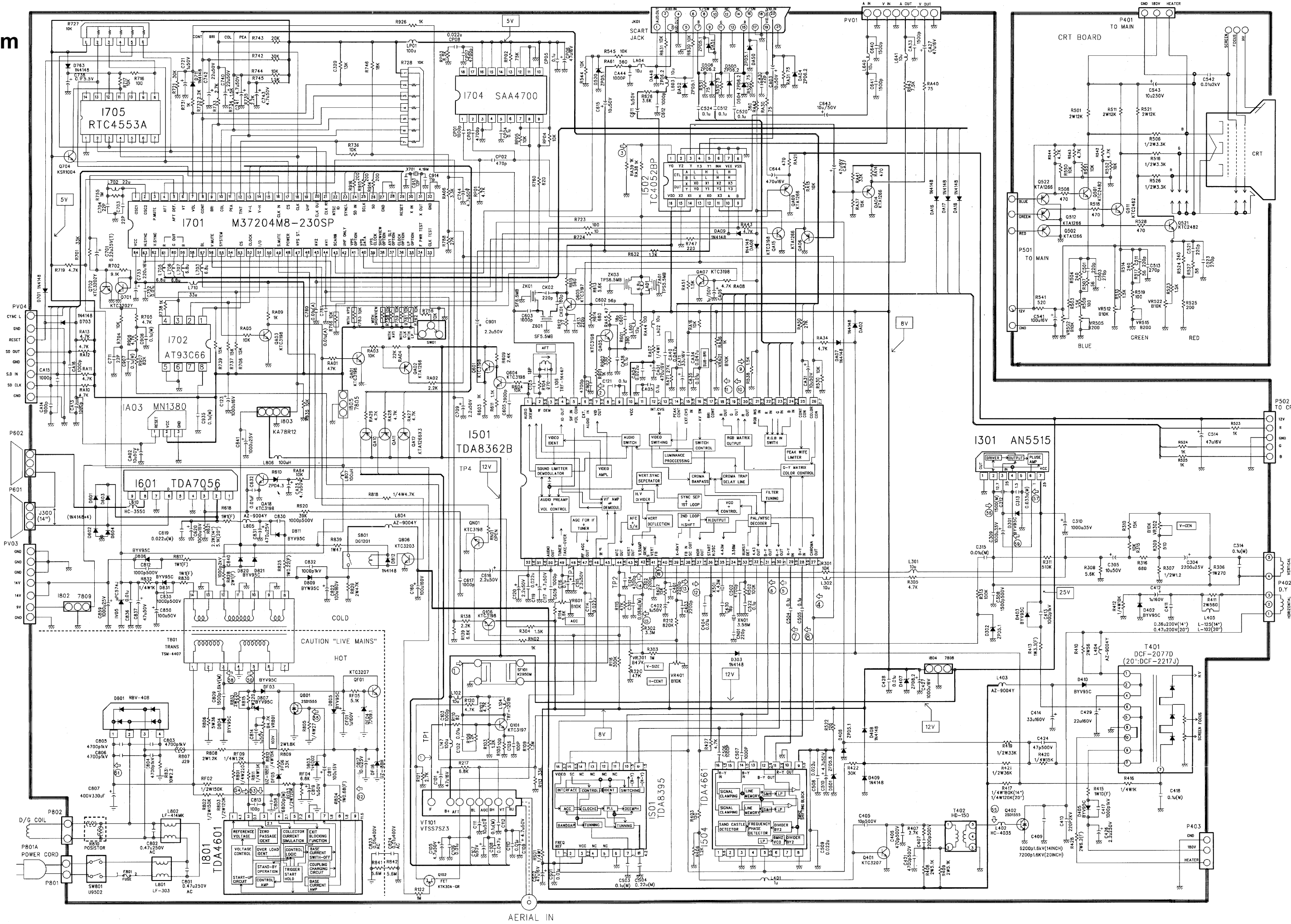

Power Servo Syscon Diagram (DVT 1484P)

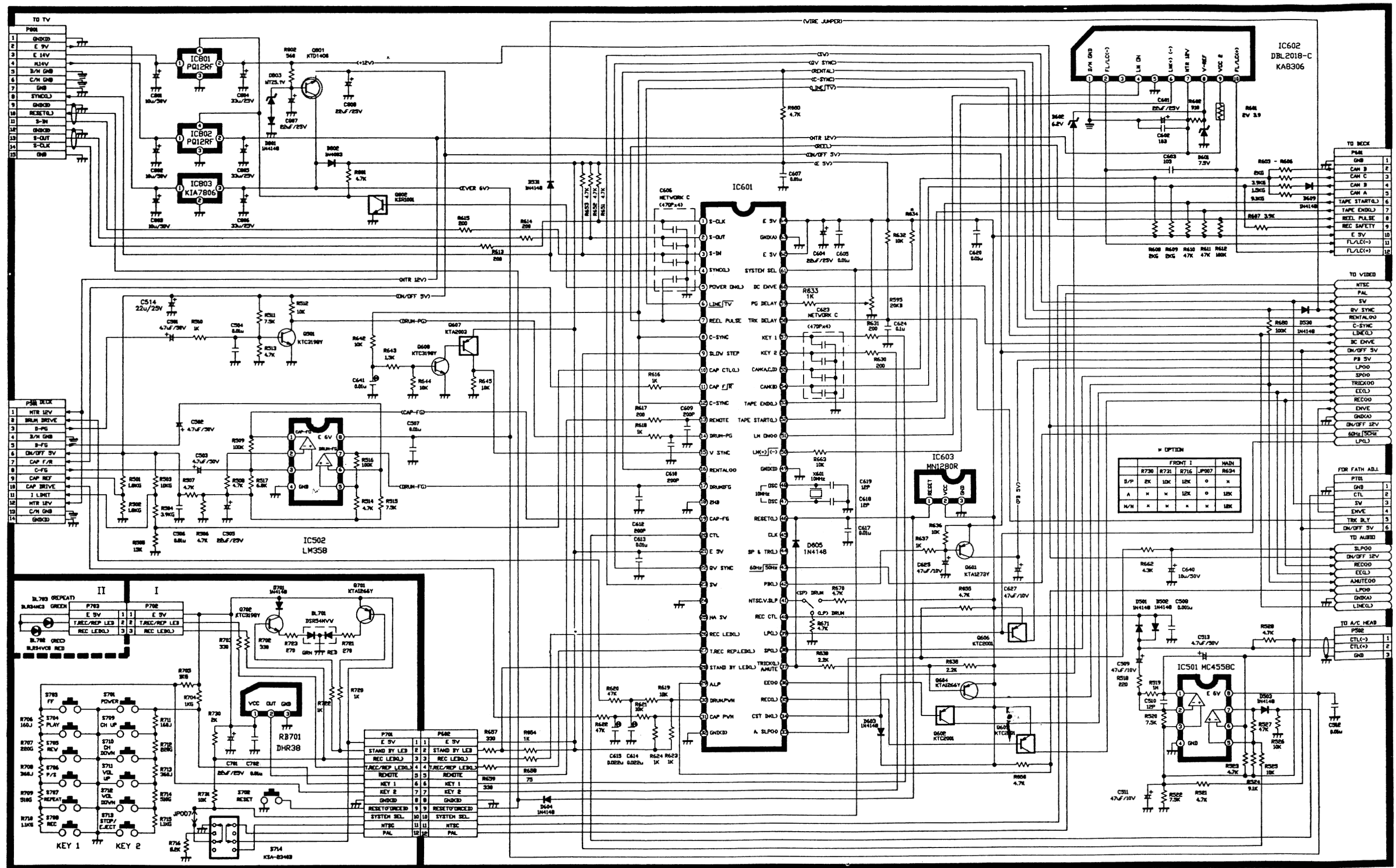

Power Servo Syscon Diagram (DVT 2084P)

