

✓ APPROVED

✓ APPROVED

# AZEDA-INTEGRATED

PWA: K3885, SCHEM: J3964  
VER : 3A

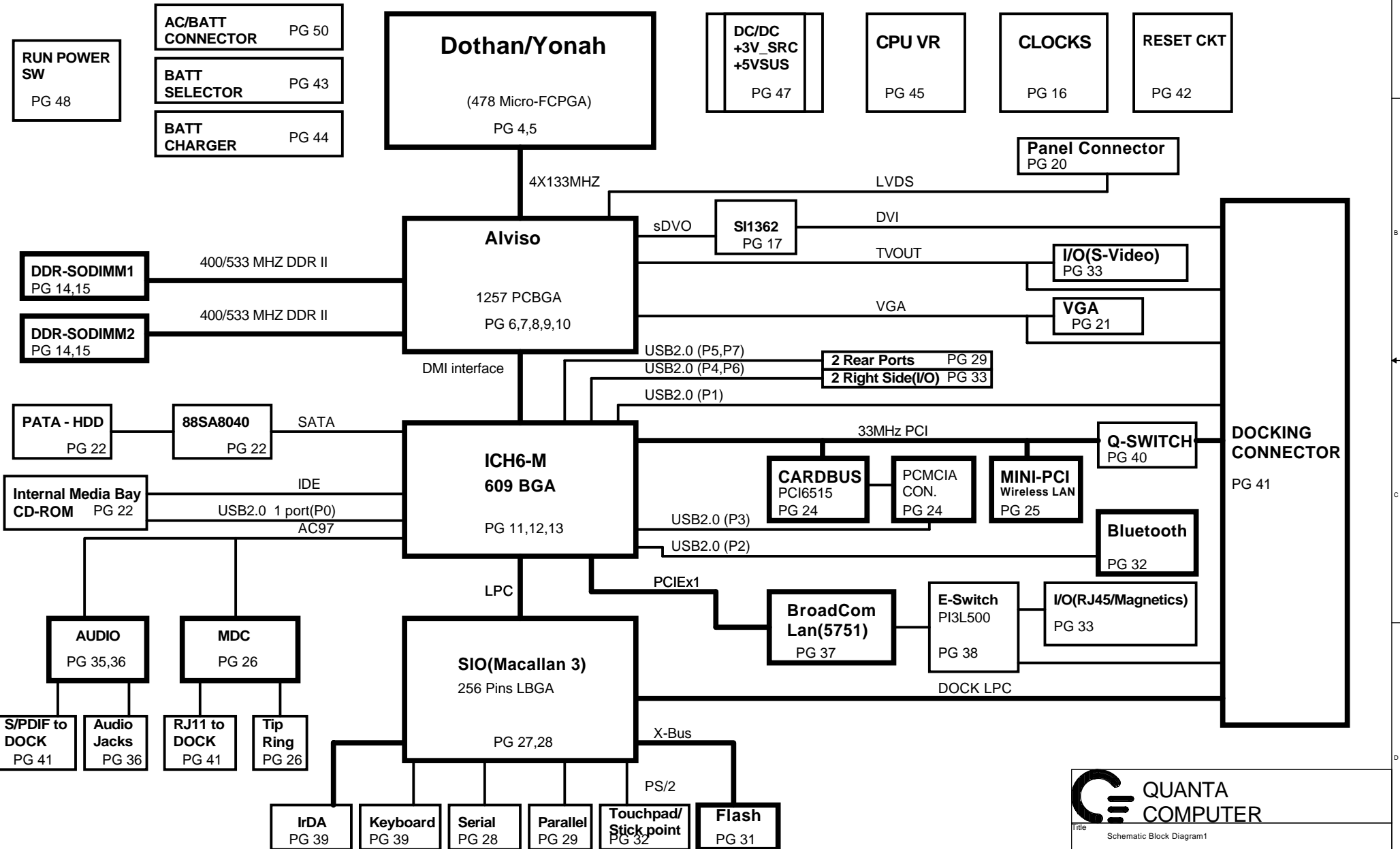

Blank Page

 QUANTA COMPUTER		
Title		
Size	Document Number JMSB	Rev 1A
Date: 星期五, 十月 29, 2004	Sheet 2	of 50

INDEX

Pg#	Description	DNI LIST
1	Schematic Block Diagram 1	
2	Blank Page	
3	Front Page	
4-5	Dothan	
6-10	Alviso	
11-13	ICH6	
14-15	DDRII SO-DIMM(200P)	
16	Clock Generator	
17	CH7306/7	
18-19	Blank Pages	
20	LCD Conn. & SSP	
21	CRT & TV Conn.	
22	SATA & IDE Conn.	
23	Screw Hole	
24	TI PIC6515	
25	Mini PCI Conn.	
26	MDC Conn.	
27-28	SIO (LPC47N354)	
29	SERIAL PORT & USB	
30	PARALLEL CONN.	
31	Flash ROM	
32	TOUCH PAD & BLUE TOOTH	
33	Switch Board Conn. & LED	
34	FAN & Thermal	
35-36	Audio CODEC (STAC9751) & Phone Jack	
37-38	LOM (BCM5751), Switch	
39	FIR	
40-41	Docking Conn. & Q-Switch	
42	Power Good	
43-44	Battery Selector & Charger	
45	CPU Power	
46	1.8V,0.9V,1.5V,1.05V	
47	3VALW/5V/3V/Power ON	
48	RUN Power Switch	
49	VGA DC/DC	
50	DCIN/Batt Conn.	

Power & Ground

Label	Pg#	Description	Control Signal
DC_IN+		AC ADAPTER (20V)	
PBATT+		MAIN BATTERY + (10~17V)	
PWR_SRC		MAIN POWER (10~20V)	
RTC_PWR3_3V		RTC & PCL POWER (3_3V)	
+12V		+12V	DRUNPWROK
VHCORE		CPU CORE POWER (1.25/1.15V)	RUNPWROK
V1_2RUN		AGTL+ POWER (1.2V)	RUNPWROK
+3VRUN		SLP_S3# CTRLD POWER	RUN_ON
+3VSUS		SLP_S5# CTRLD POWER	SUS_ON
+5VALW		8051 POWER (5V)	
+5VRUN		SLP_S3# CTRLD POWER	RUN_ON
+5VSUS		SLP_S5# CTRLD POWER	SUS_ON
+5VHDD		HDD POWER (5V)	HDDC_EN#
+5VMOD		MODULE POWER (5V)	MODC_EN#
STRB#/5V		EXTERNAL FDD POWER (5V)	FDD/LPT#
+5VFAN1, +5VFAN2		FAN POWER (5V)	FAN_OFF/ON#
VDDA		AUDIO ANALOG POWER (5V)	RUN_ON
1_8VSUS		RESUME WELL IN ICH	
1_8VRUN		SLP_S3# CTRLD POWER	
+3VALW		8051 POWER (3V)	
V1_5RUN		AGP I/O POWER	
 GND	ALL PAGES	DIGITAL GROUND	
 GNDP		CPU POWER GND	
 CGNDP		CHARGER GND	
 DGNDP		DC/DC POWER GND	
 LANGND		COMBO CONN GND	



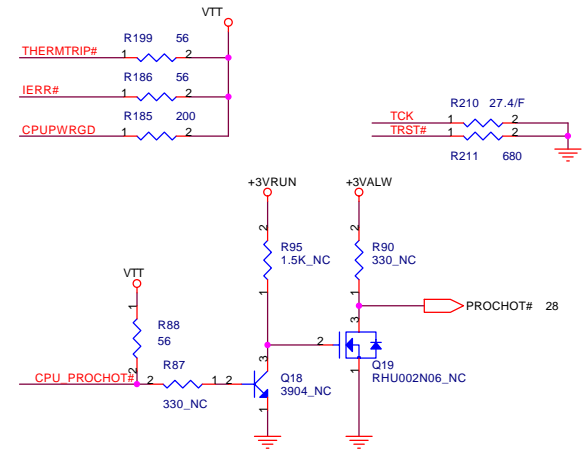
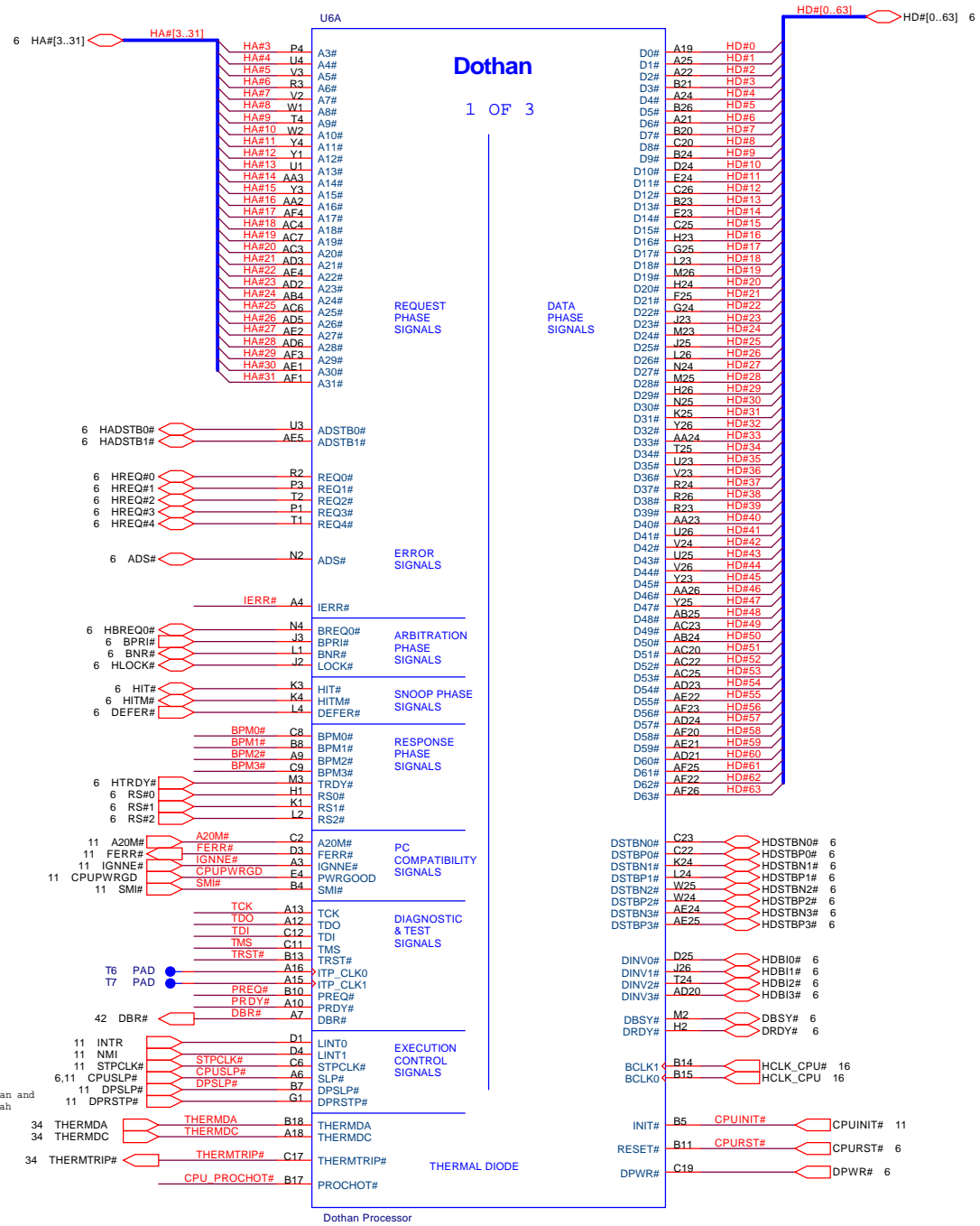

Signal	Resistor Value	Connect To	Resistor Placement
TDI	150 ohm +/- 5%	VTT	Within 2.0" of the CPU
TMS	39 ohm +/- 5%	VTT	Within 2.0" of the CPU
TRST#	680 ohm +/- 5%	GND	Within 2.0" of the CPU
TCK	27 ohm +/- 5%	GND	Within 2.0" of the CPU
TDO	Open	VTT	Within 2.0" of the CPU
ITP_EN	R268 Depop	+3VRUN	Close to CK410M Pin8

Note: Populate R214, R216, C366, and R268 when ITP connector is populated.

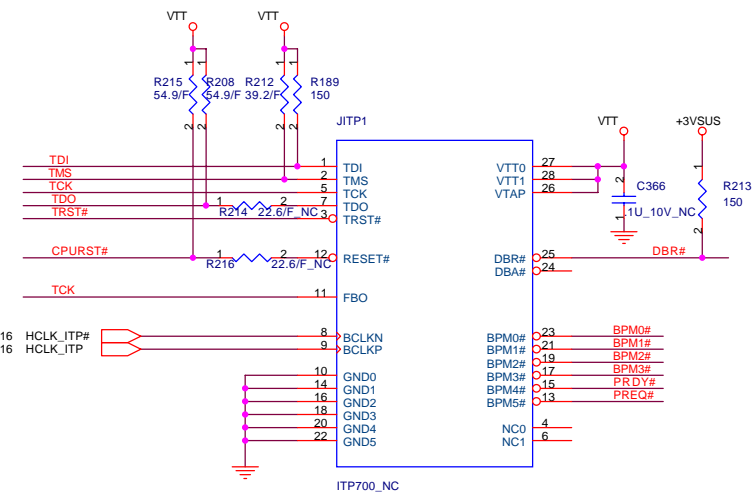

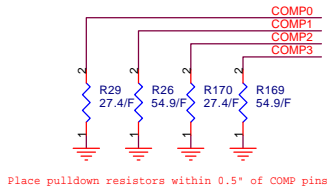

Place pulldown resistors within 0.5" of COMP pins

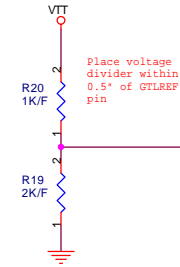

- COMP0 P25
- COMP1 P26
- COMP2 AB2
- COMP3 AB1

- GTLREF0 AD26
- TEST1 C5
- TEST2 F23
- NC1 B2
- RSVD2 C3
- RSVD3 AF7
- RSVD4 AC1
- RSVD5 E26

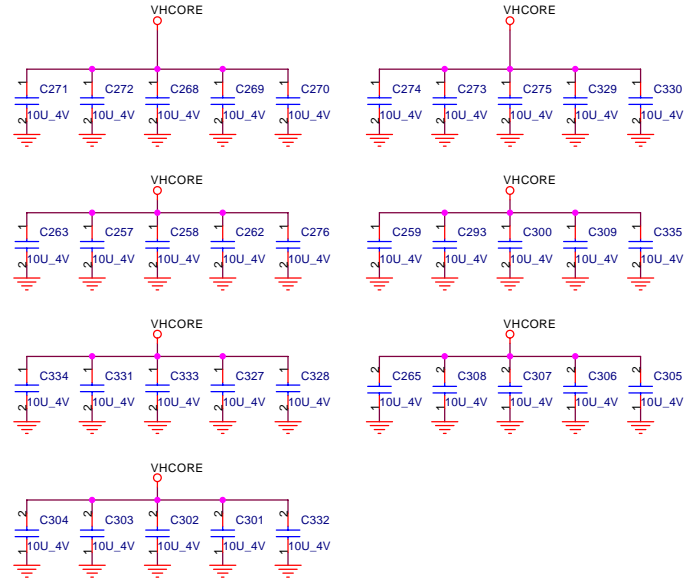
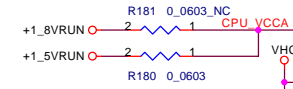
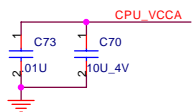

Total caps = 2633 uF  
ESR = 15m ohm/5 // 5m ohm/25 // 5m ohm/15

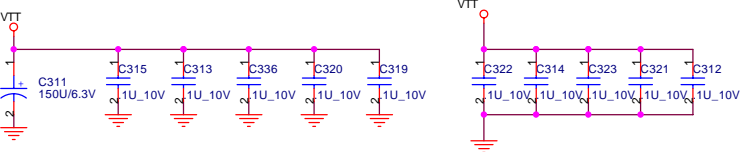

**Dothan**  
2 OF 3

POWER, GROUND, RESERVED SIGNALS

U6B	COMP0	P25	VSS00	A2
	COMP1	P26	VSS01	A5
	COMP2	AB2	VSS02	A8
	COMP3	AB1	VSS03	A11
			VSS04	A14
			VSS05	A17
			VSS06	A20
			VSS07	A23
			VSS08	A26
			VSS09	B3
			VSS10	B6
			VSS11	B9
			VSS12	B12
			VSS13	B15
			VSS14	B18
			VSS15	B22
			VSS16	B25
			VSS17	C1
			VSS18	C4
			VSS19	C7
			VSS20	C10
			VSS21	C13
			VSS22	C15
			VSS23	C18
			VSS24	C21
			VSS25	C24
			VSS26	D2
			VSS27	D5
			VSS28	D7
			VSS29	D9
			VSS30	D11
			VSS31	D13
			VSS32	D15
			VSS33	D17
			VSS34	D19
			VSS35	D21
			VSS36	D23
			VSS37	D26
			VSS38	E3
			VSS39	E6
			VSS40	E8
			VSS41	E10
			VSS42	E12
			VSS43	E14
			VSS44	E16
			VSS45	E18
			VSS46	E20
			VSS47	E22
			VSS48	E25
			VSS49	F4
			VSS50	F5
			VSS51	F7
			VSS52	F9
			VSS53	F11
			VSS54	F13
			VSS55	F15
			VSS56	F17
			VSS57	F19
			VSS58	F21
			VSS59	F24
			VSS60	G2
			VSS61	G6
			VSS62	G22
			VSS63	G23
			VSS64	G26
			VSS65	H3
			VSS66	H5
			VSS67	H21
			VSS68	H25
			VSS69	J1
			VSS70	J4
			VSS71	J6
			VSS72	J22
			VSS73	J24
			VSS74	K2
			VSS75	K5
			VSS76	K5
			VSS77	K21
			VSS78	K23
			VSS79	K26
			VSS80	L3
			VSS81	L6
			VSS82	L22
			VSS83	L25
			VSS84	M1
			VSS85	M4
			VSS86	M5
			VSS87	M21
			VSS88	M24
			VSS89	N3
			VSS90	N6
			VSS91	N22
			VSS92	N23
			VSS93	N26
			VSS94	P2
			VSS95	P5
			VSS96	P21
			VSS97	P24
			VSS98	R1
			VSS99	R4

**Dothan**  
3 OF 3

POWER, GROUND AND NC

**VID**

U6C	D10	VCCP0	VSS120	W23
	D12	VCCP1	VSS121	W26
	D14	VCCP2	VSS122	Y2
	D16	VCCP3	VSS123	Y5
	E11	VCCP4	VSS124	Y21
	E13	VCCP5	VSS125	Y24
	E15	VCCP6	VSS126	AA1
	F10	VCCP7	VSS127	AA4
	F12	VCCP8	VSS128	AA6
	F14	VCCP9	VSS129	AA8
	F16	VCCP10	VSS130	AA10
	K6	VCCP11	VSS131	AA12
	L5	VCCP12	VSS132	AA14
	L21	VCCP13	VSS133	AA16
	M6	VCCP14	VSS134	AA18
	M22	VCCP15	VSS135	AA20
	N5	VCCP16	VSS136	AA25
	N21	VCCP17	VSS137	AB3
	P6	VCCP18	VSS138	AB5
	P22	VCCP19	VSS139	AB7
	R5	VCCP20	VSS140	AB9
	R21	VCCP21	VSS141	AB11
	T6	VCCP22	VSS142	AB13
	T22	VCCP23	VSS143	AB15
	U21	VCCP24	VSS144	AB17
	P23	VCCQ0	VSS145	AB19
	W4	VCCQ1	VSS146	AB21
			VSS147	AB23
			VSS148	AB26
			VSS149	AC2
			VSS150	AC5
			VSS151	AC8
			VSS152	AC10
			VSS153	AC12
			VSS154	AC14
			VSS155	AC16
			VSS156	AC18
			VSS157	AC21
			VSS158	AC24
			VSS159	AD1
			VSS160	AD4
			VSS161	AD7
			VSS162	AD9
			VSS163	AD11
			VSS164	AD13
			VSS165	AD15
			VSS166	AD17
			VSS167	AD19
			VSS168	AD22
			VSS169	AD25
			VSS170	AE3
			VSS171	AE6
			VSS172	AE8
			VSS173	AE10
			VSS174	AE12
			VSS175	AE14
			VSS176	AE16
			VSS177	AE18
			VSS178	AE20
			VSS179	AE23
			VSS180	AE26
			VSS181	AF2
			VSS182	AF5
			VSS183	AF9
			VSS184	AF11
			VSS185	AF13
			VSS186	AF15
			VSS187	AF17
			VSS188	AF19
			VSS189	AF21
			VSS190	AF24
			VSS191	

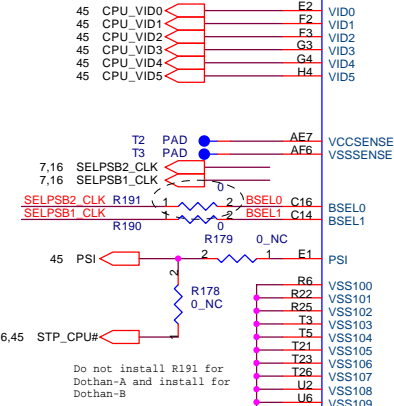

Do not install R191 for Dothan-A and install for Dothan-B



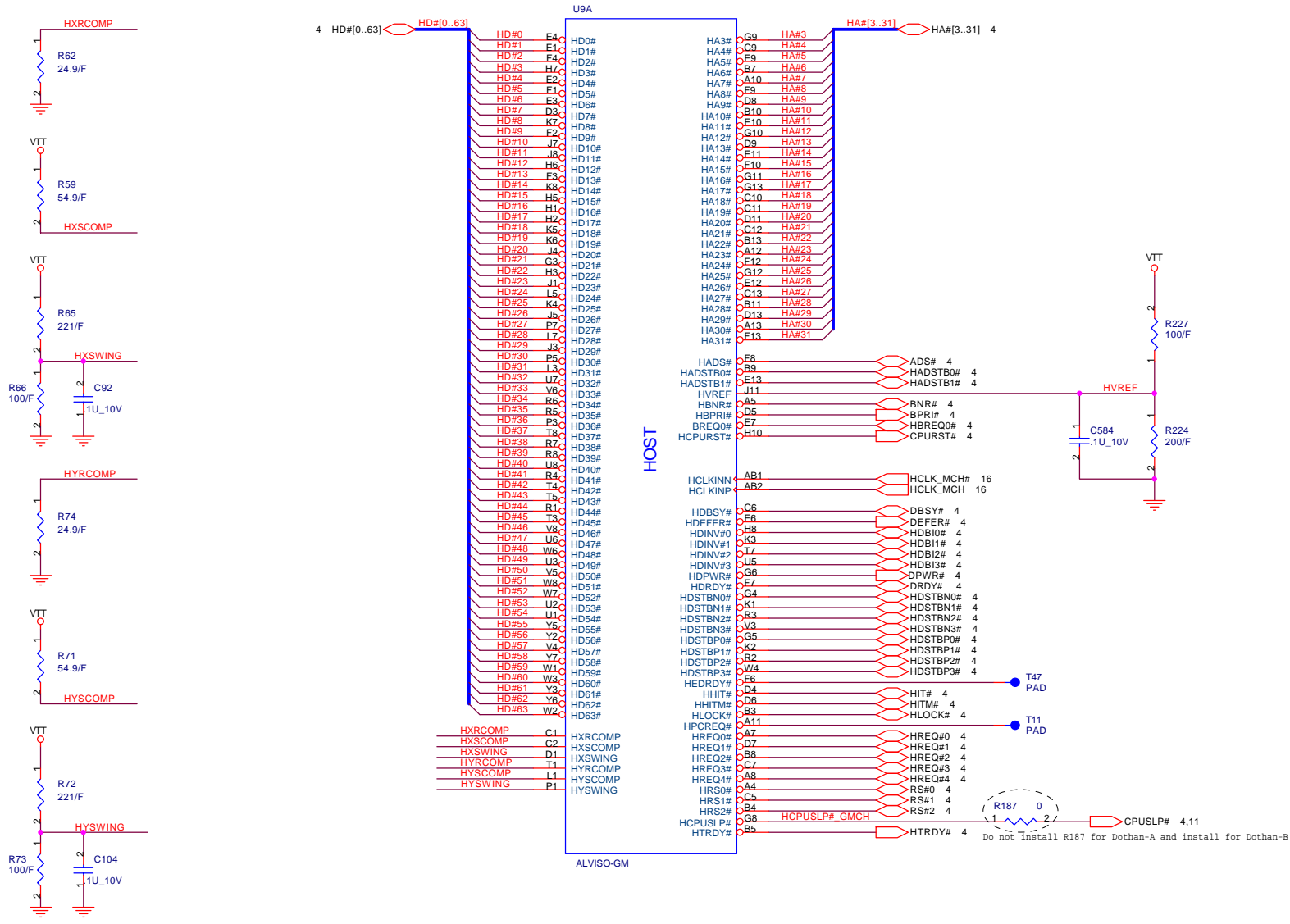



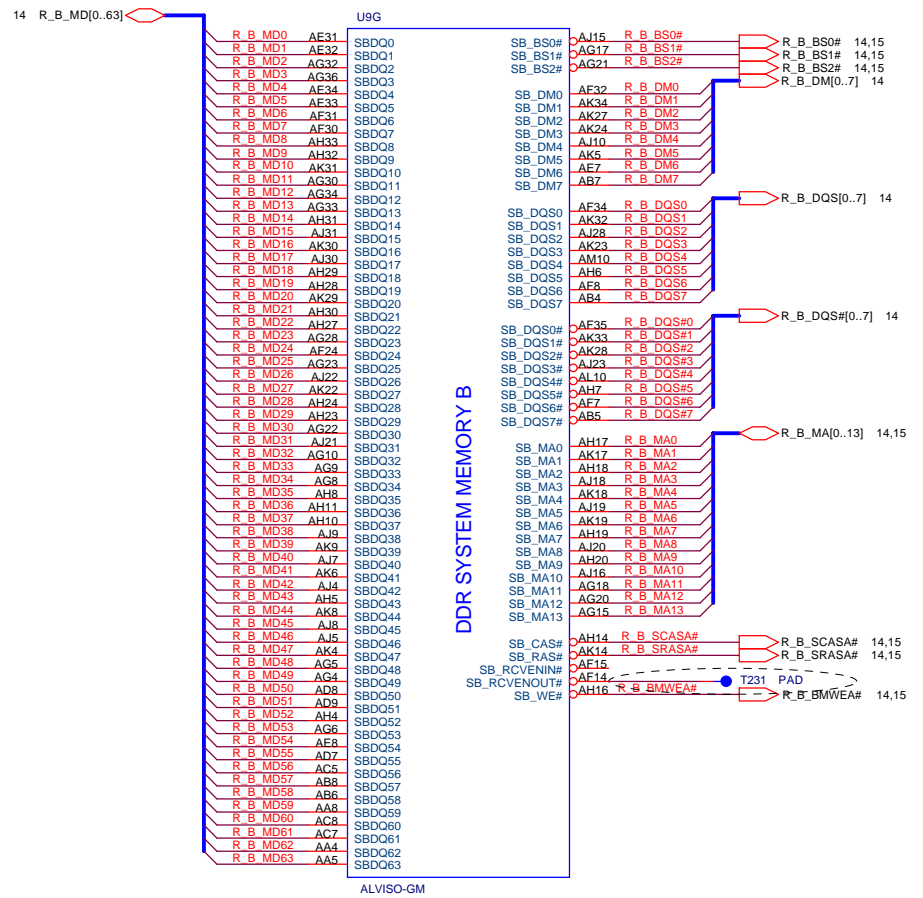
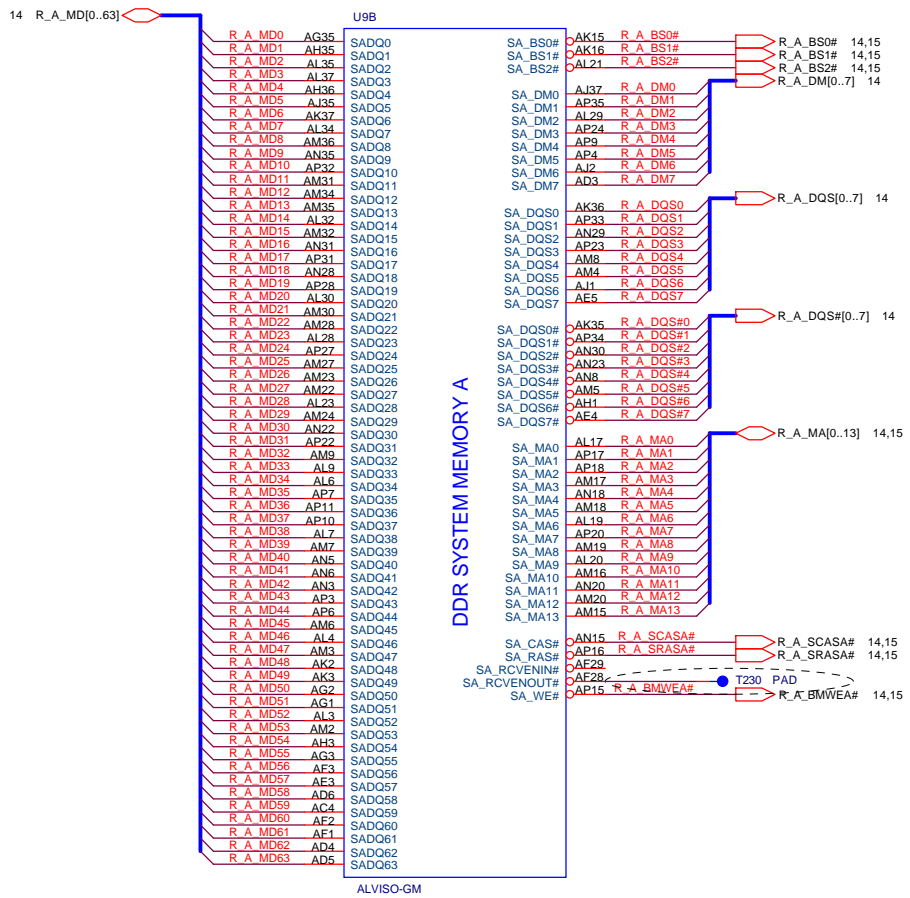



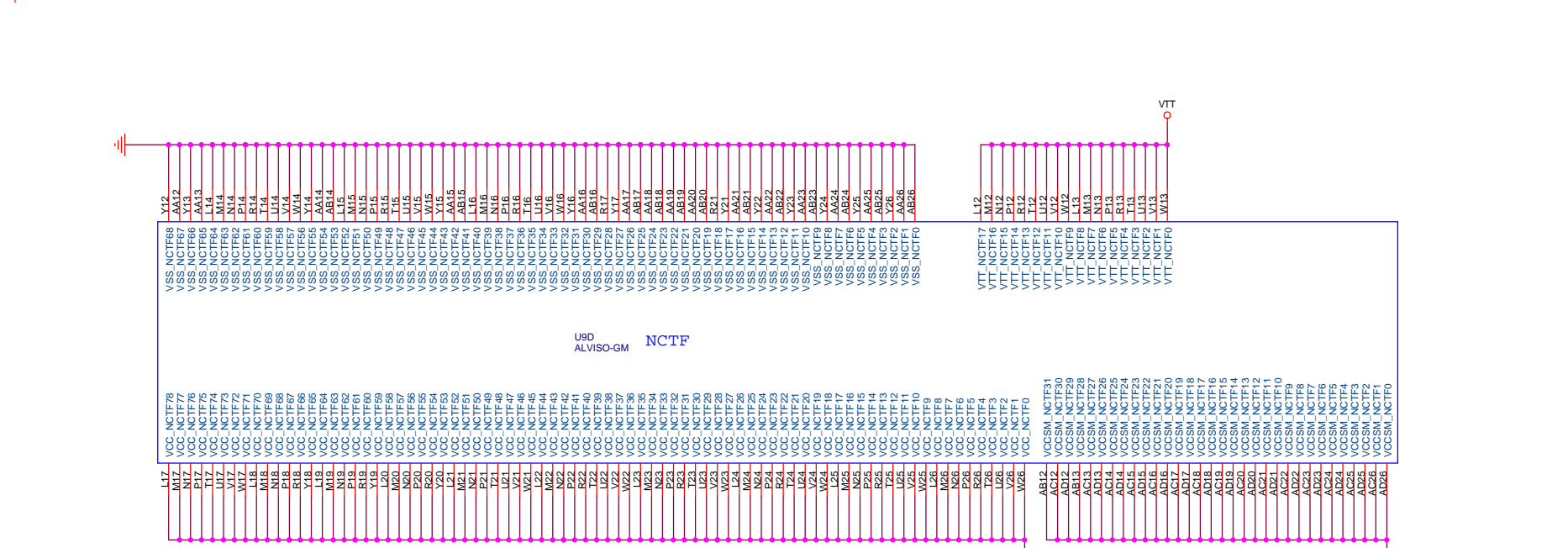
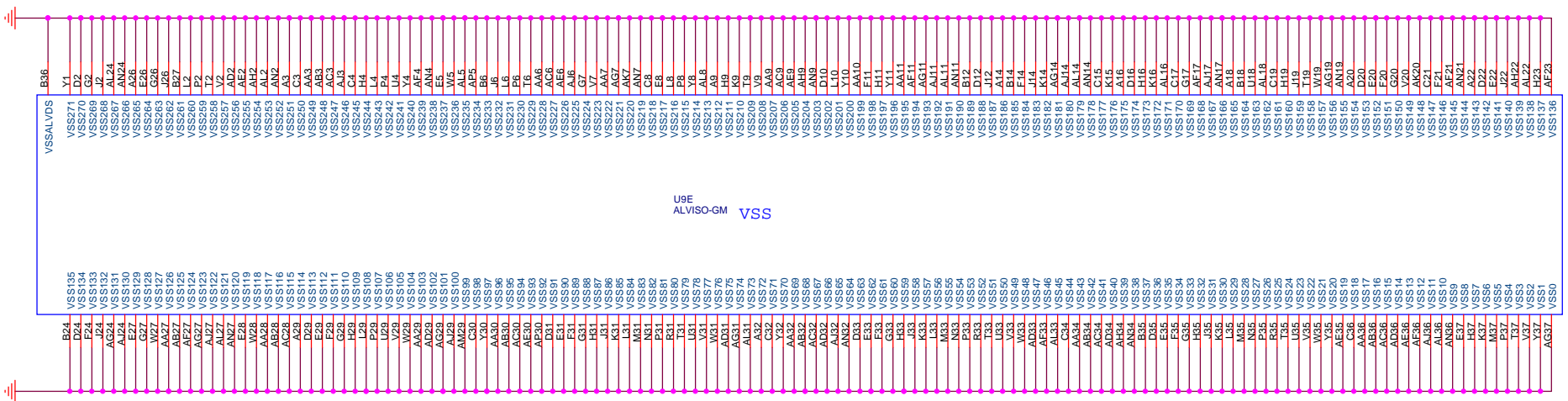

Title		Alviso (VSS,NCTF)
Size	Document Number	Rev
	JMSB	2A
Date:	星期三, 十月 29, 2004	Sheet 10 of 50



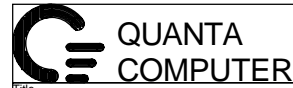
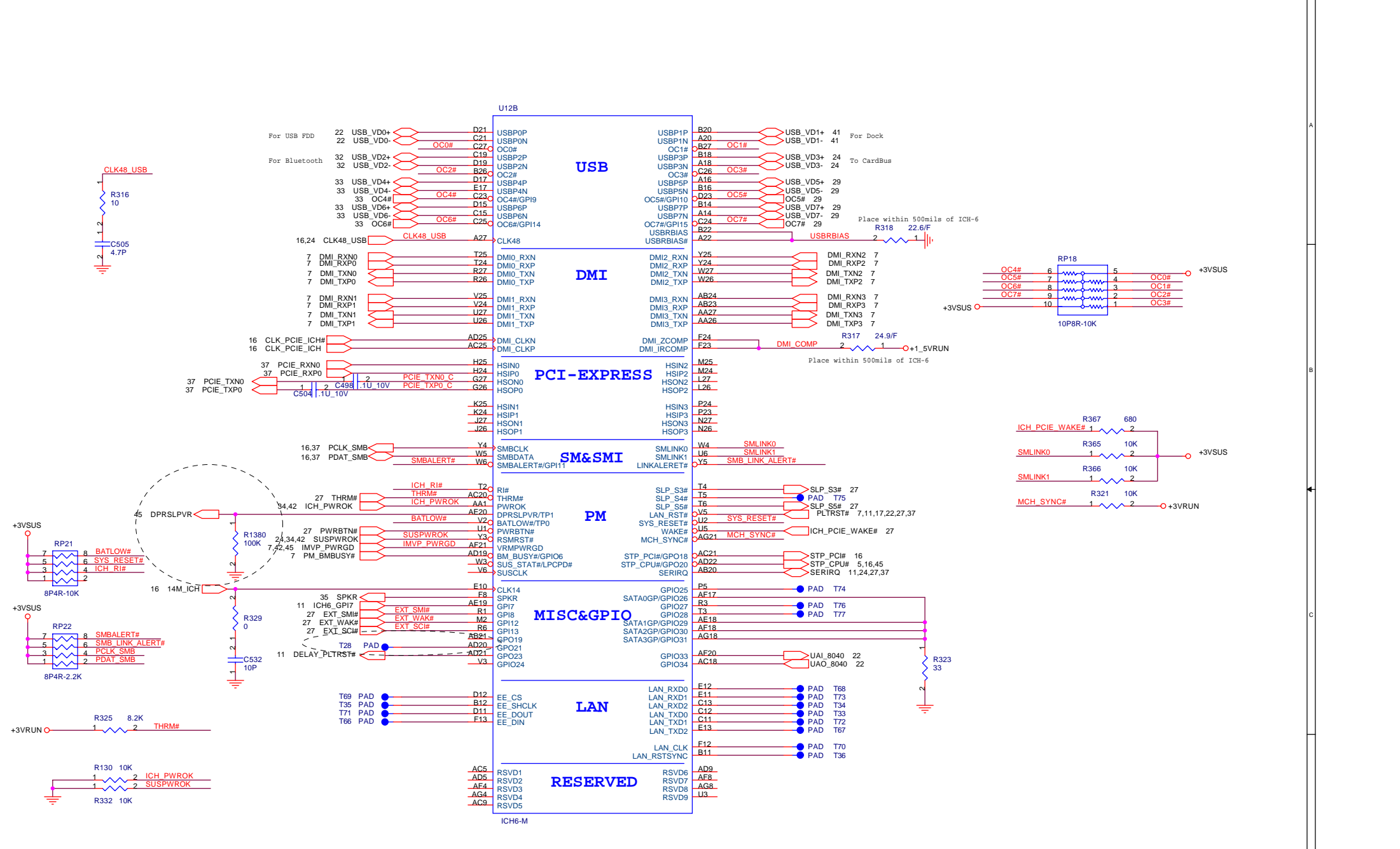





R\_A\_MA[0..13] 8,14

R\_B\_MA[0..13] 8,14

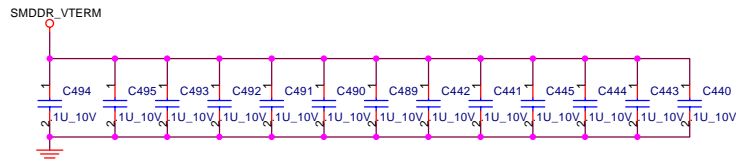

Layout note: Place 1 cap close to every 1 R-pack terminated to SMDDR\_VTERM.

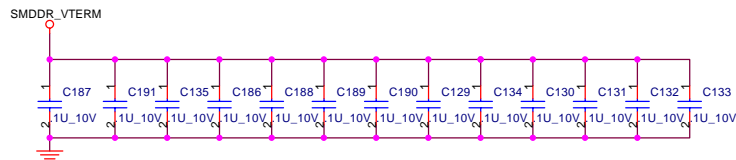

Layout note: Place 1 cap close to every 1 R-pack terminated to SMDDR\_VTERM.

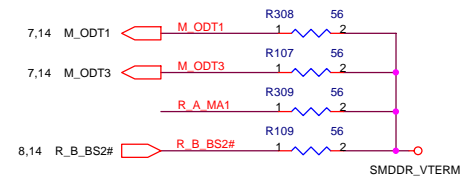
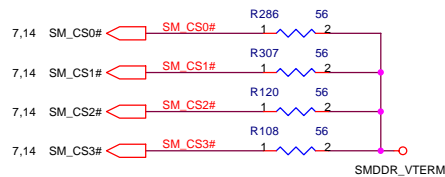
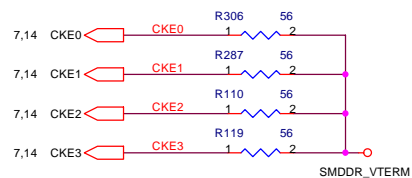
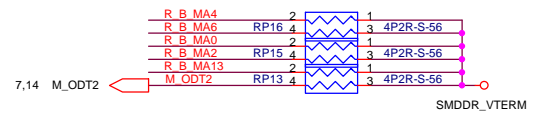
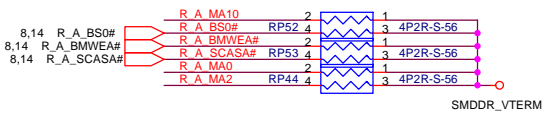
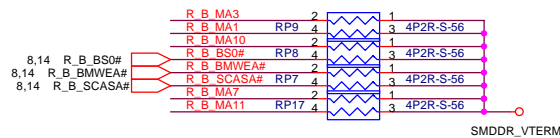
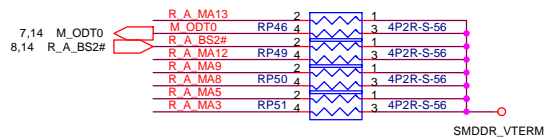
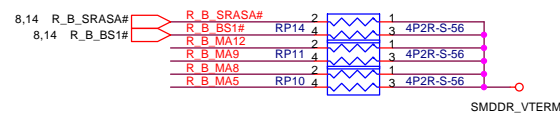
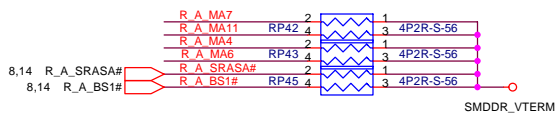

FSC	FSB	FSA	CPU	SRC	PCI
1	0	1	100	100	33
0	0	1	133	100	33
0	1	1	166	100	33
0	1	0	200	100	33
0	0	0	266	100	33
1	0	0	333	100	33
1	1	0	400	100	33
1	1	1	RSVD	100	33

Place these termination to close CK410M.

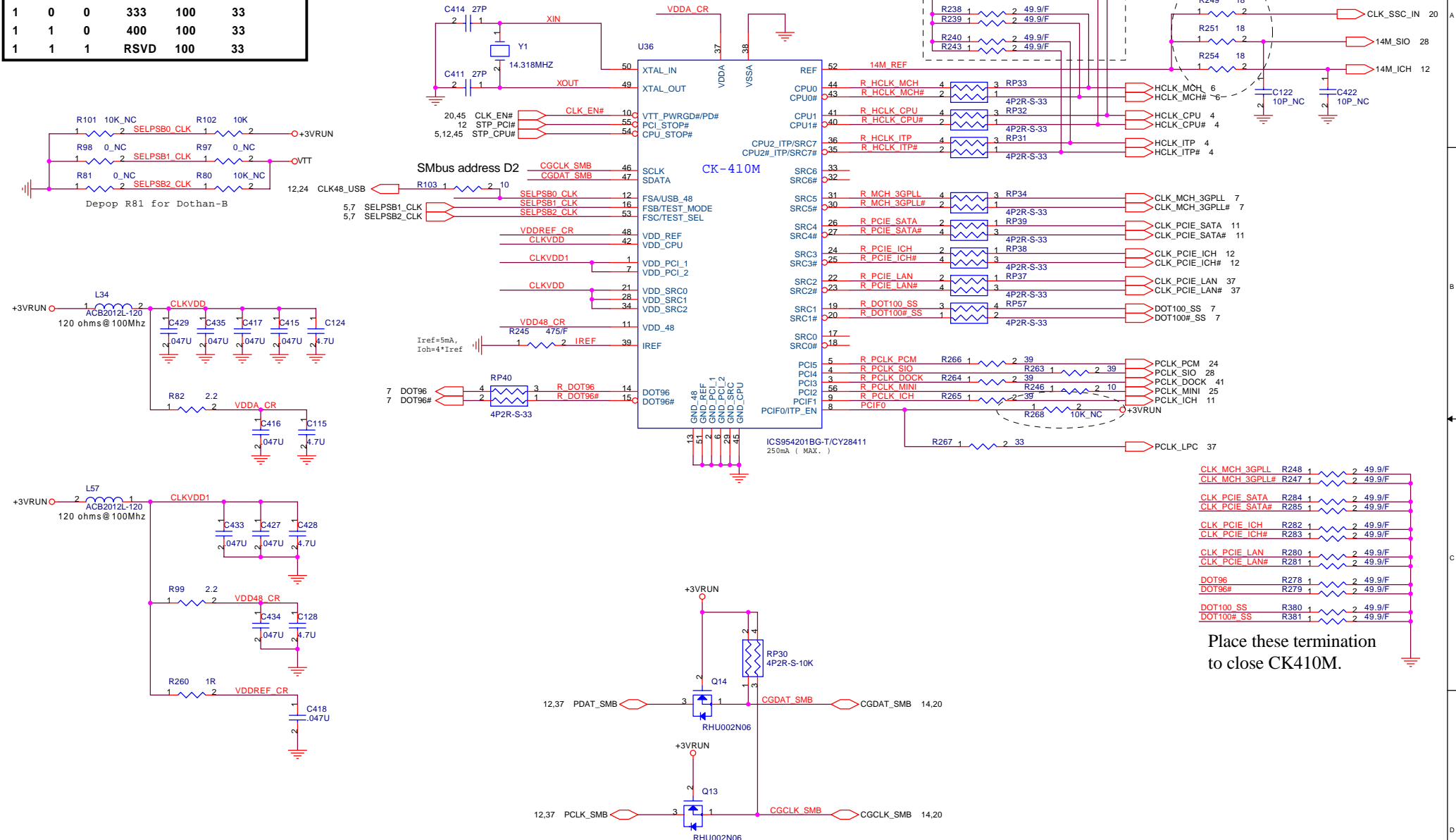

- CLK\_MCH\_3GPLL R248 1 2 49.9/F
- CLK\_MCH\_3GPLL# R247 1 2 49.9/F
- CLK\_PCIE\_SATA R284 1 2 49.9/F
- CLK\_PCIE\_SATA# R285 1 2 49.9/F
- CLK\_PCIE\_ICH R282 1 2 49.9/F
- CLK\_PCIE\_ICH# R283 1 2 49.9/F
- CLK\_PCIE\_LAN R280 1 2 49.9/F
- CLK\_PCIE\_LAN# R281 1 2 49.9/F
- DOT96 R278 1 2 49.9/F
- DOT96# R279 1 2 49.9/F
- DOT100\_SS R380 1 2 49.9/F
- DOT100#\_SS R381 1 2 49.9/F

Place these termination to close CK410M.

These are for backdrive issue

**QUANTA  
COMPUTER**

Title: CLOCK GENERATOR

Size: Document Number	Rev: 2A
JMSB	

Date: 星期三, 十月 29, 2004      Sheet: 16 of 50

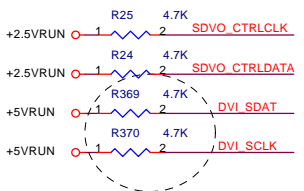

Placed this capacitor close to OVCC.

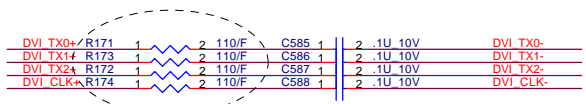
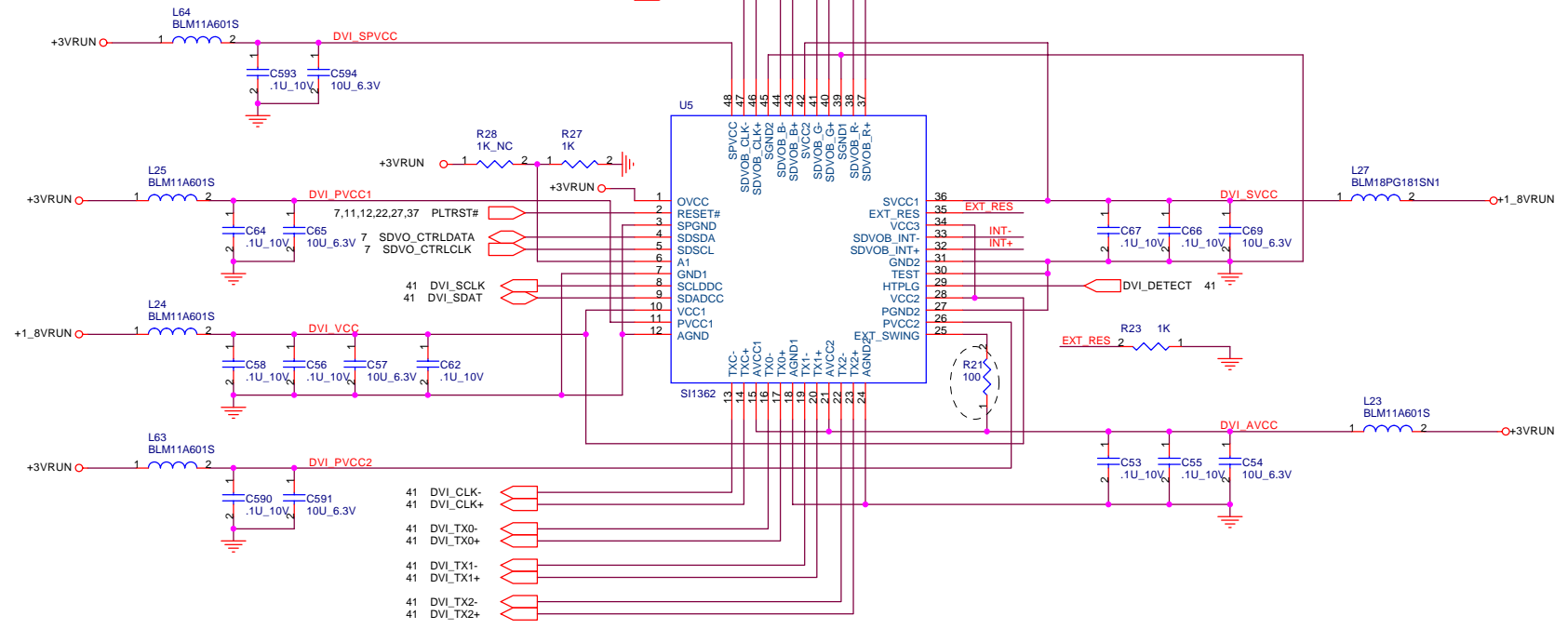
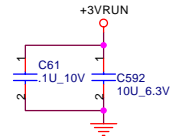

Put these 4 Resistors and 4 Capacitors close to the TX pin of SDVO device



Title		
S11 1362		
Size	Document Number	Rev
	JMSB	2A
Date:	星期五, 十月 29, 2004	Sheet 17 of 50

**BLANK PAGE**

 <b>QUANTA COMPUTER</b>		
Title		
Size	Document Number JMSB	Rev 1A
Date: 星期五, 十月 29, 2004	Sheet 18 of 50	E

**BLANK PAGE**

 <b>QUANTA COMPUTER</b>		
Title		
Size	Document Number JMSB	Rev 1A
Date: 星期五, 十月 29, 2004	Sheet 19 of 50	

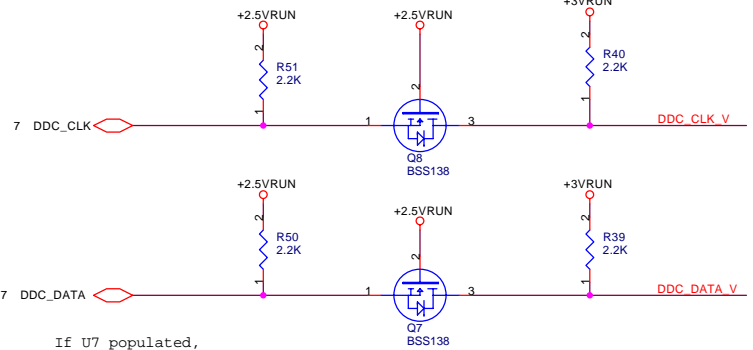
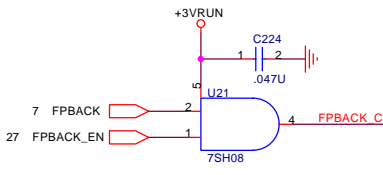
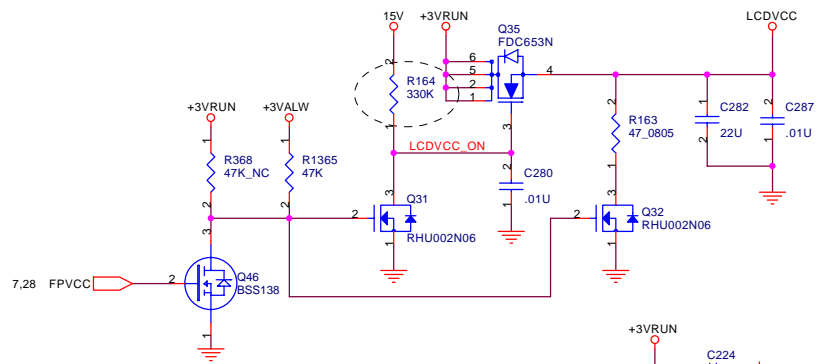

If U7 populated,  
R379=NC; If U7=NC,  
R379=0-ohm

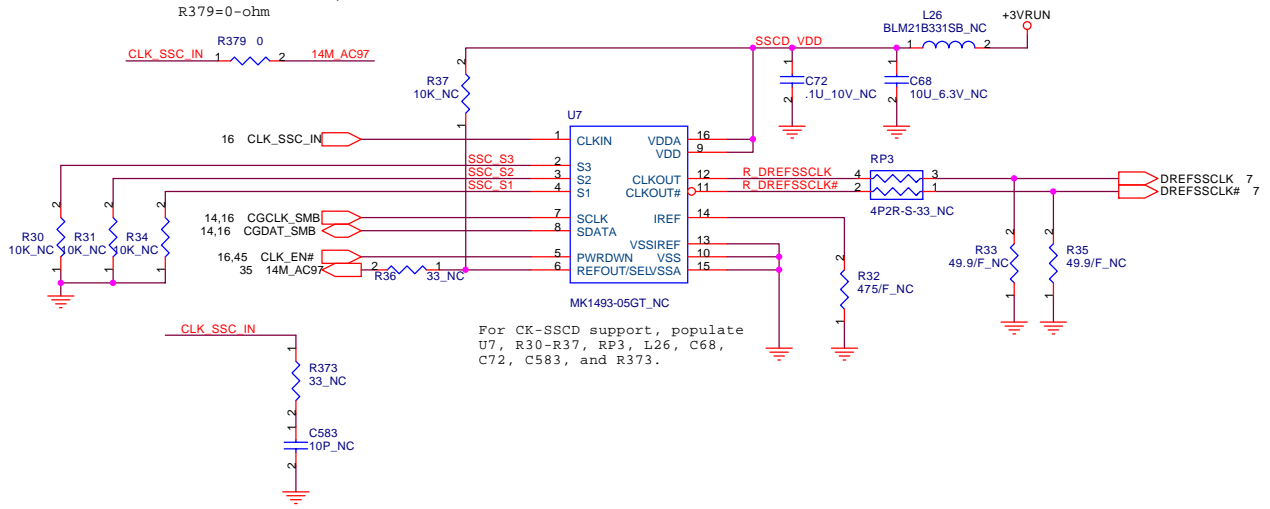

For CK-SSCD support, populate  
U7, R30-R37, RP3, L26, C68,  
C72, C583, and R373.

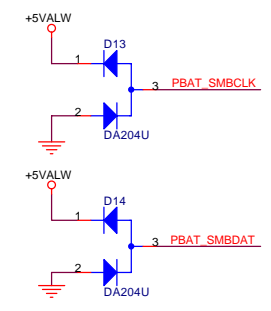
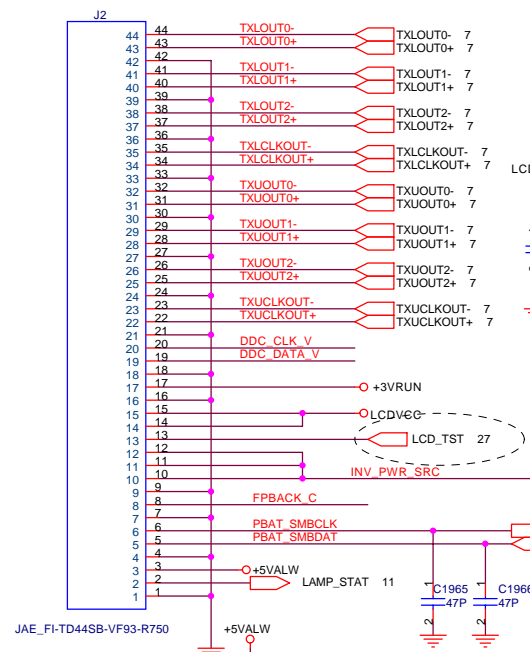

Adress : A9H -Contrast  
AAH -Backlight

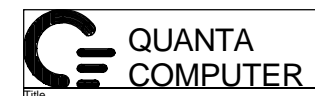
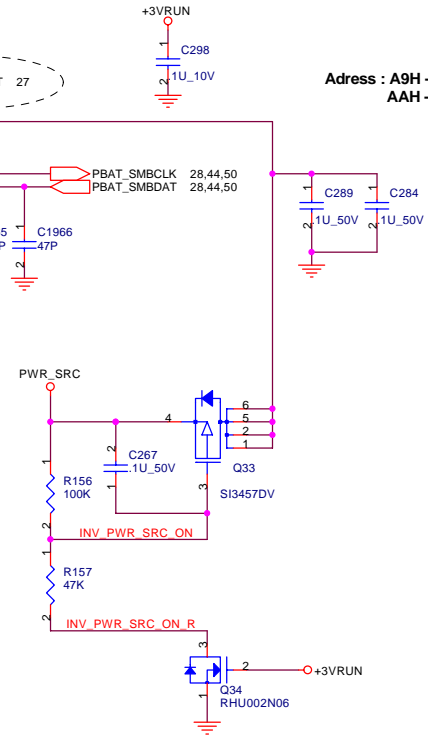

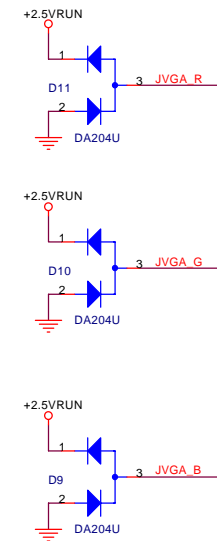
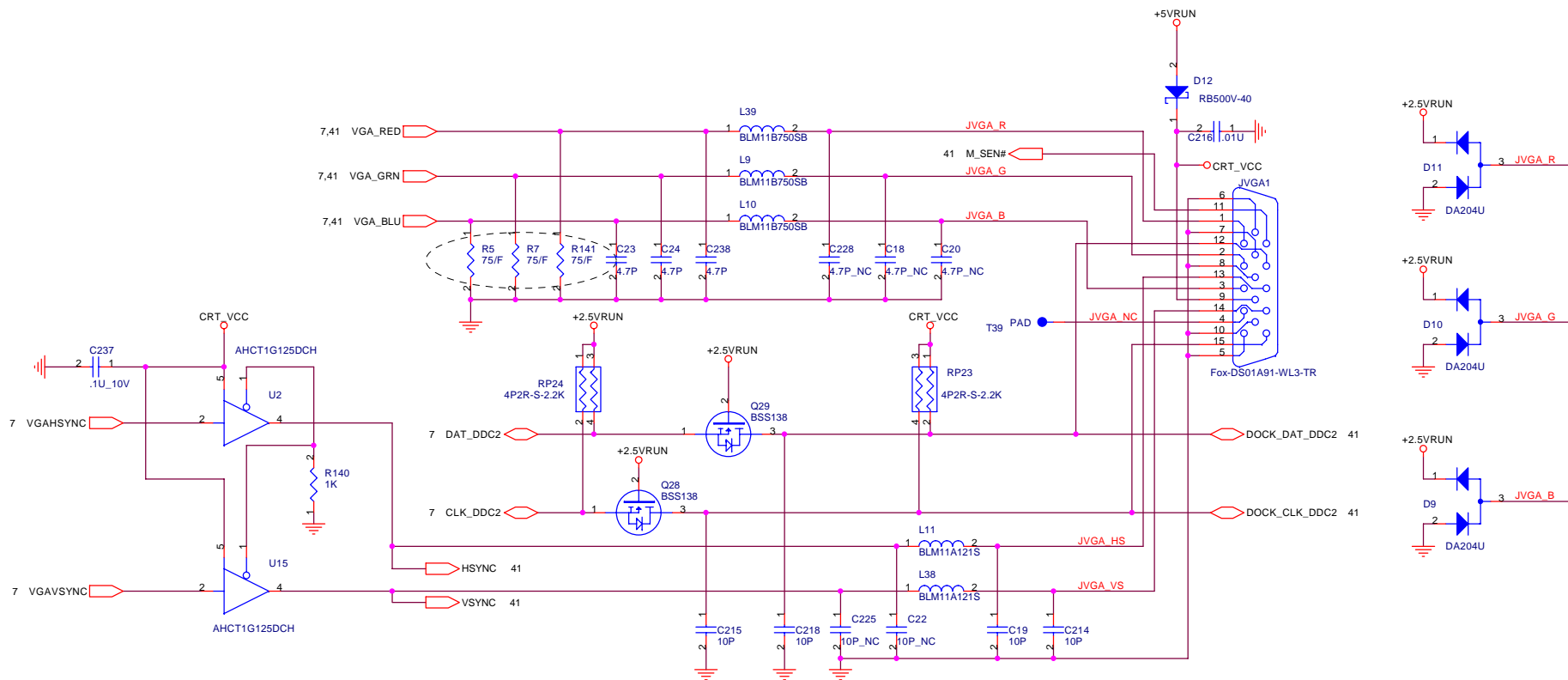

Title CRT&TV CONN		
Size	Document Number JMSB	Rev 2A
Date:	星期五, 十月 29, 2004	Sheet 21 of 50



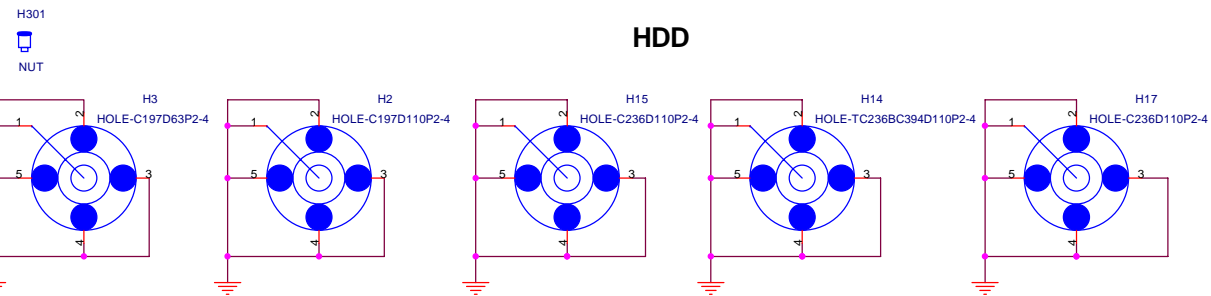
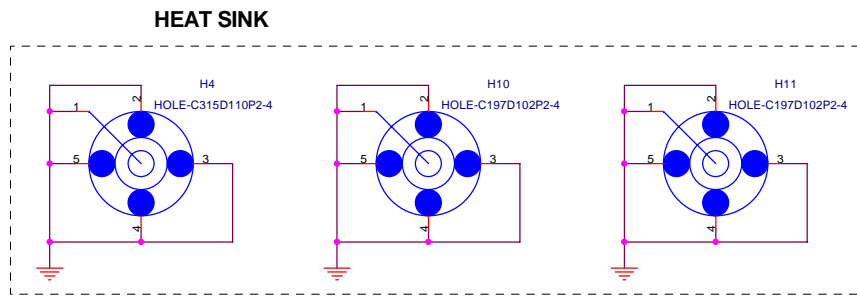
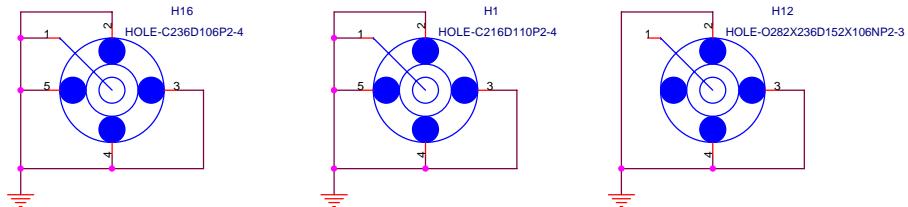
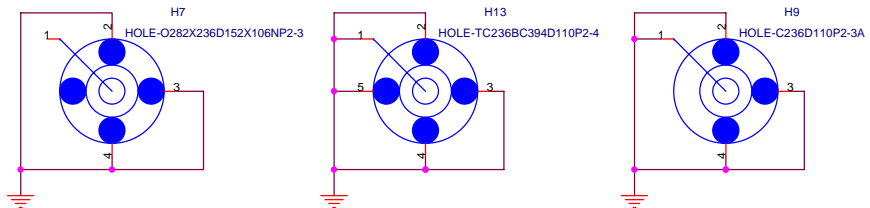
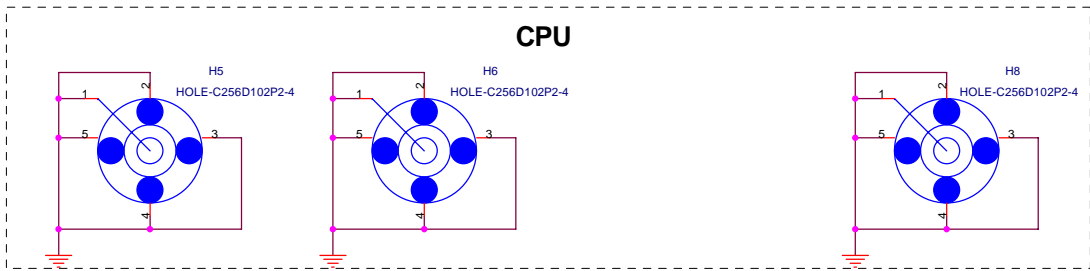
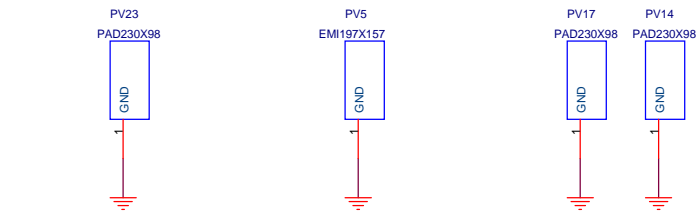
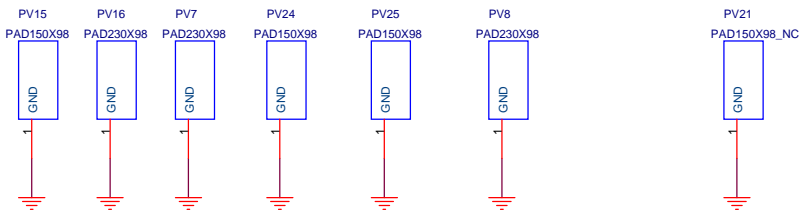
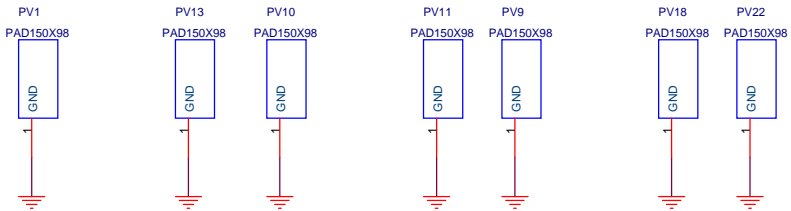
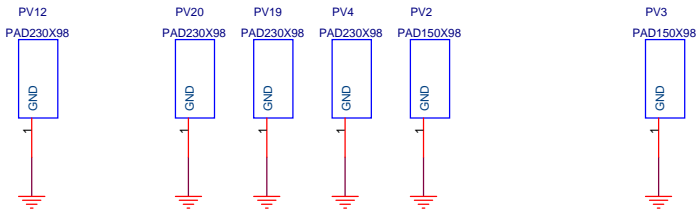

QUANTA COMPUTER		
Title SCREW PAD		
Size	Document Number JM5B	Rev 2A
Date: 星期五, 十月 29, 2004	Sheet 23	of 51



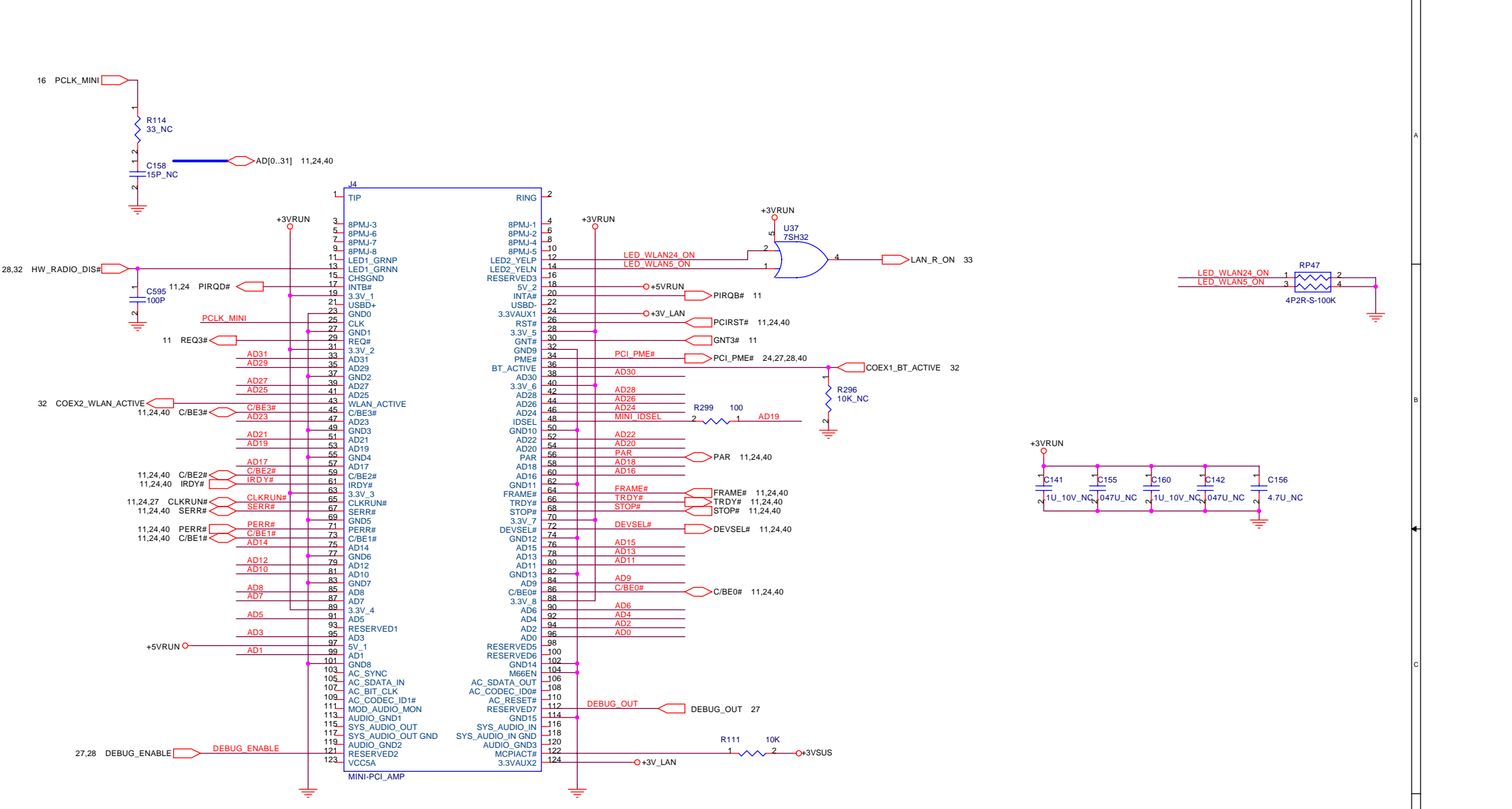

Title MINI-PCI & MDC		
Size	Document Number JMSB	Rev 2A
Date:	星期五, 十月 29, 2004	Sheet 25 of 50

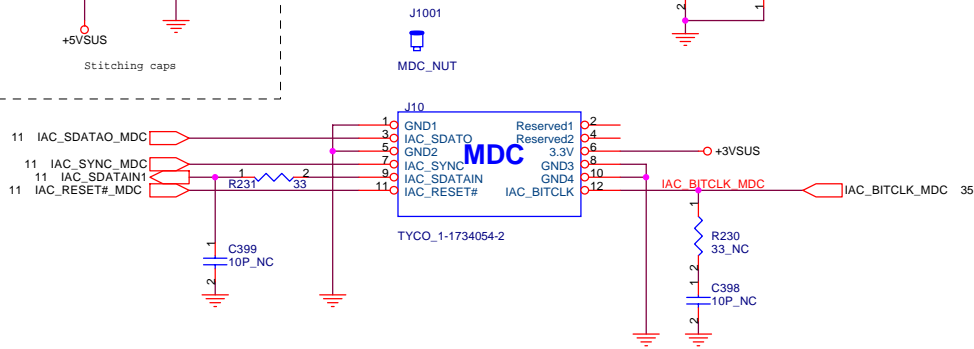
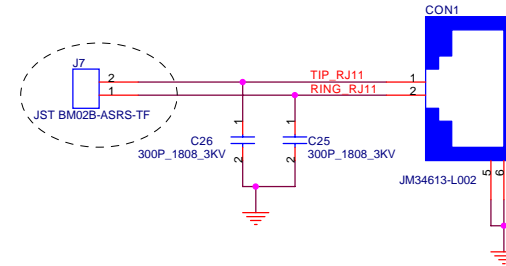
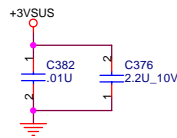
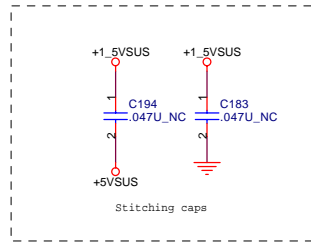

Title		
MDC CONN.		
Size	Document Number	Rev
	JMSB	2A
Date:	星期五, 十月 29, 2004	Sheet 26 of 50

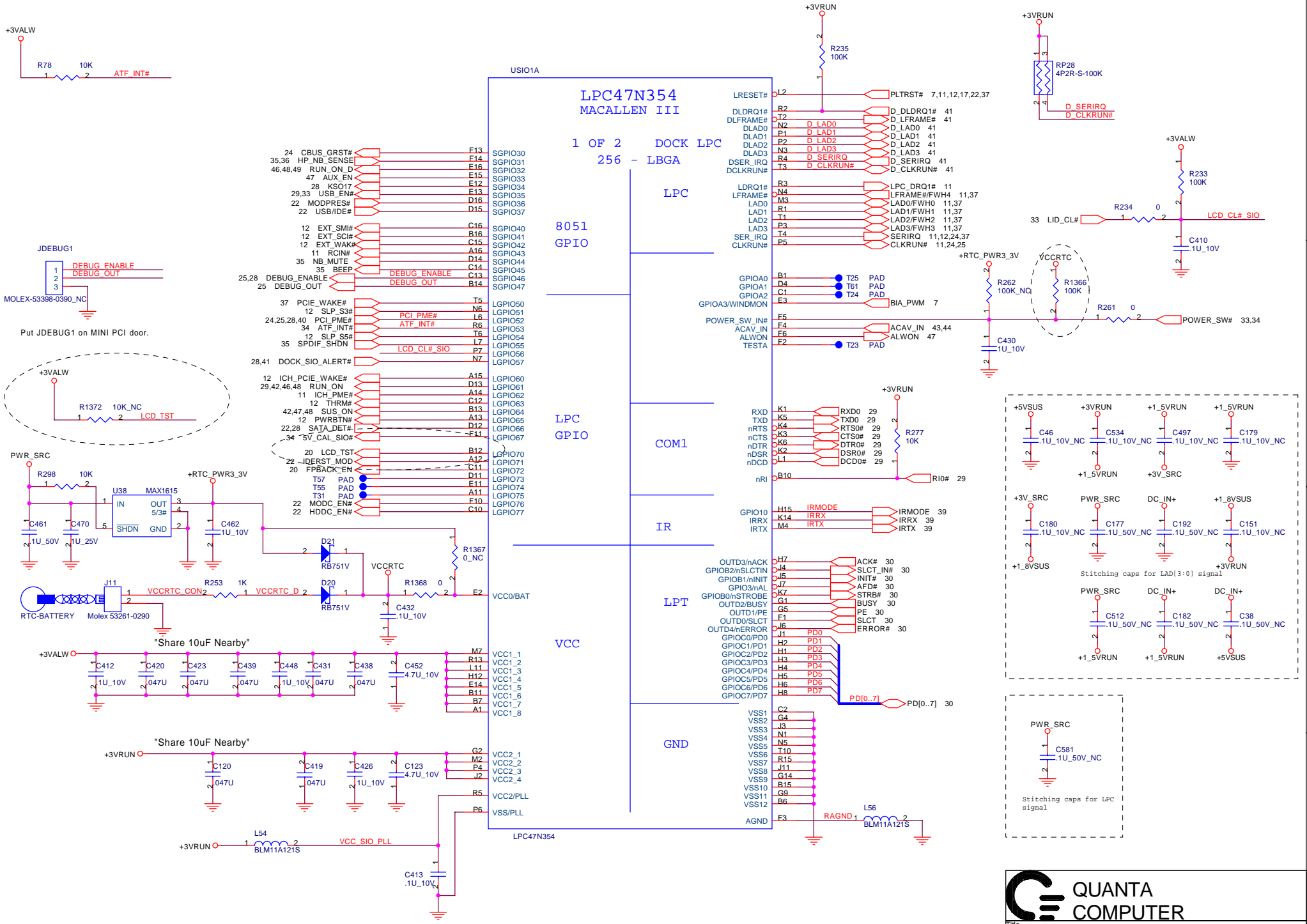



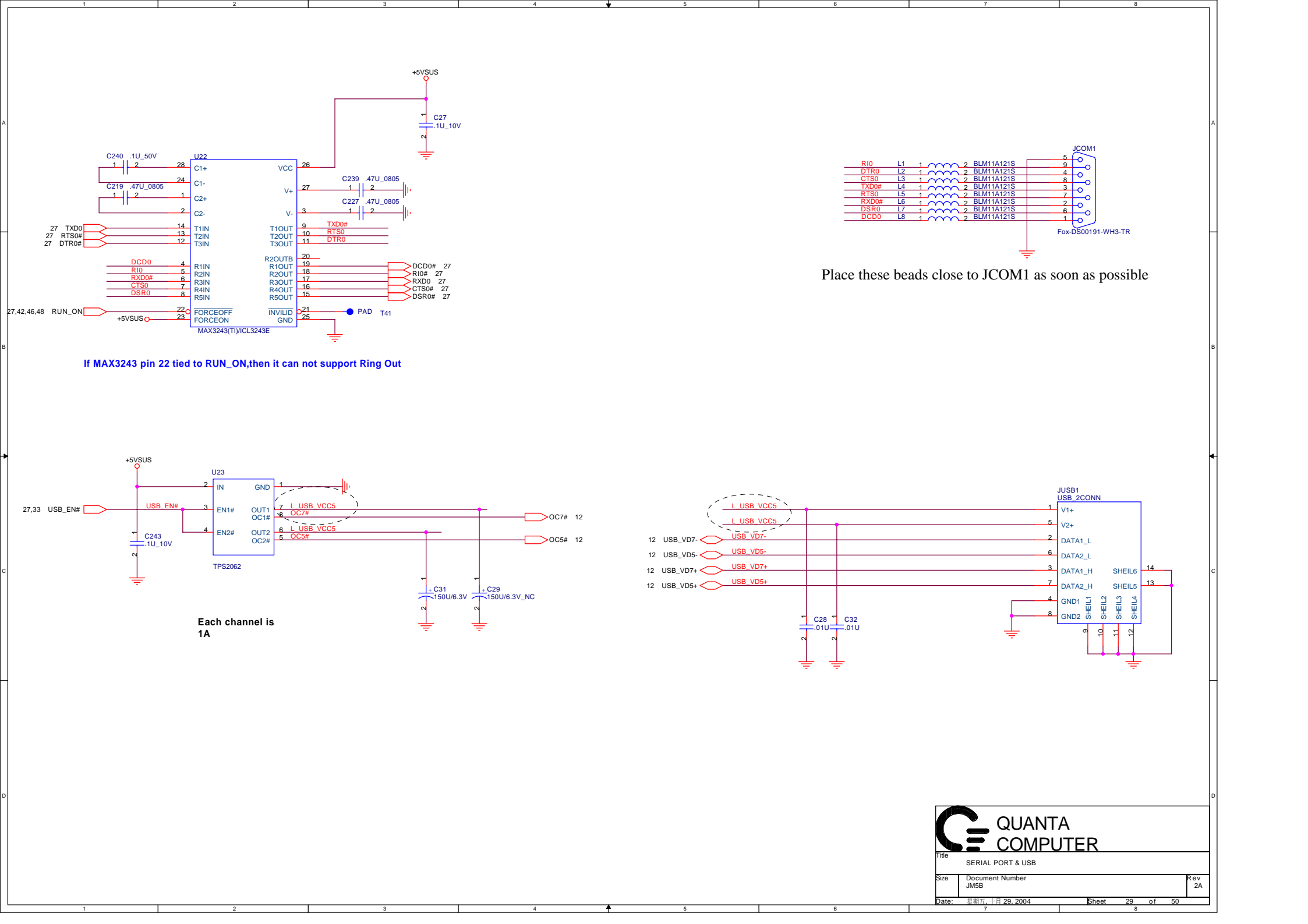

If MAX3243 pin 22 tied to RUN\_ON, then it can not support Ring Out

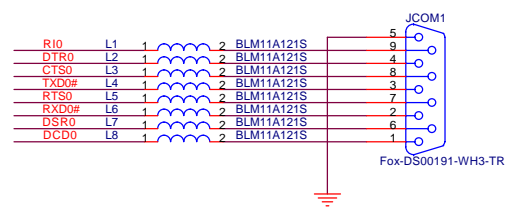

Place these beads close to JCOM1 as soon as possible

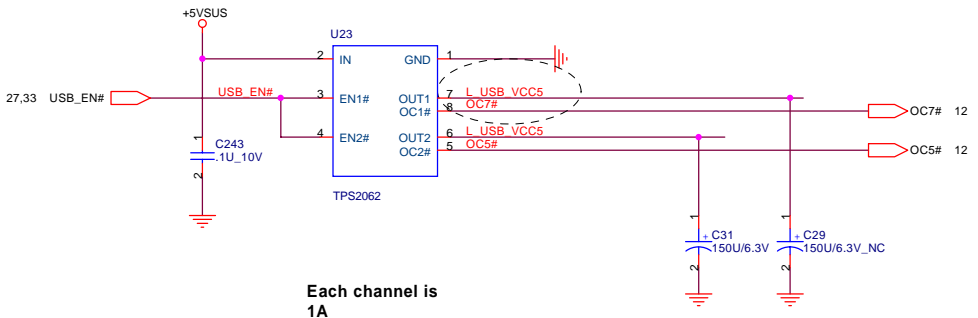

Each channel is 1A

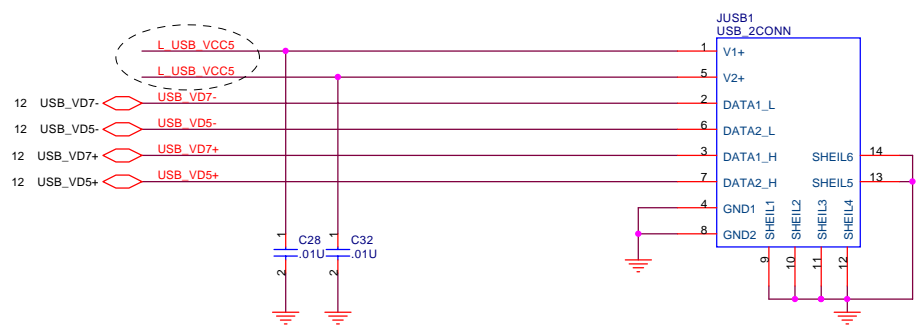

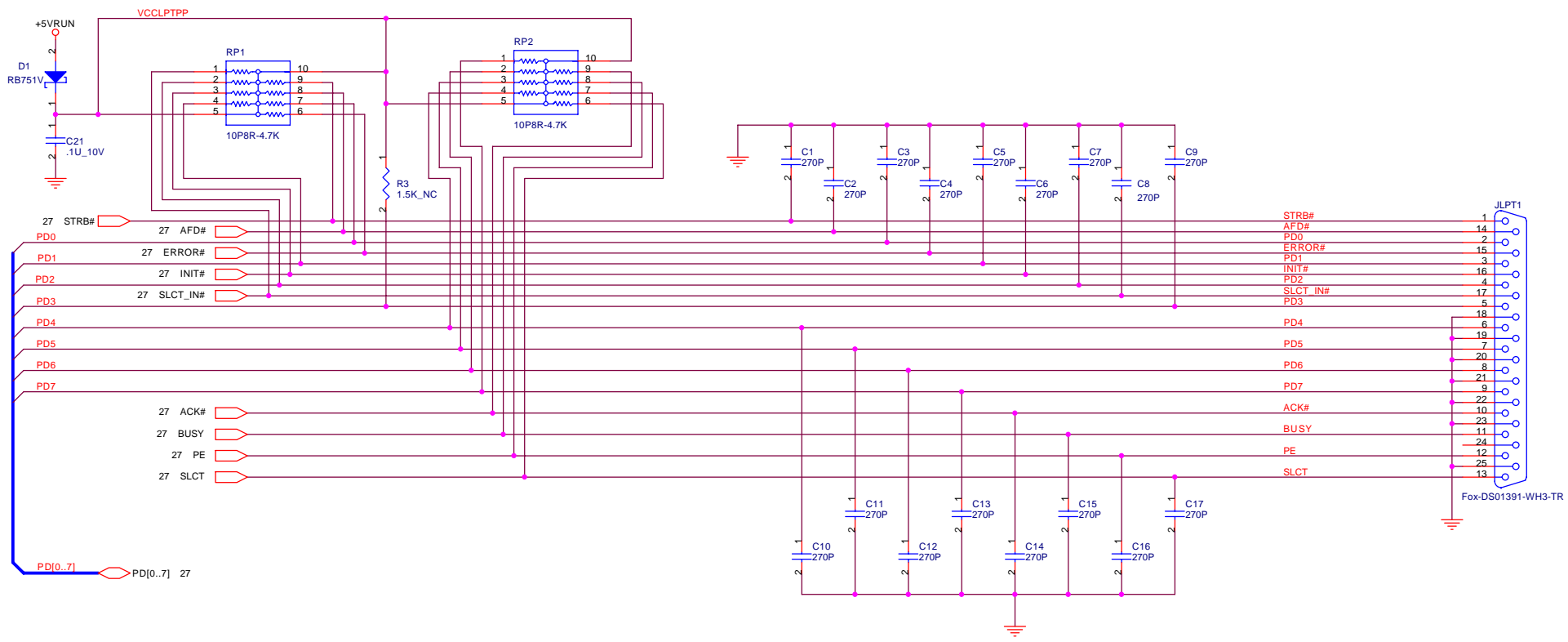

### 8Mbit (1M Byte),NO PLCC TYPE

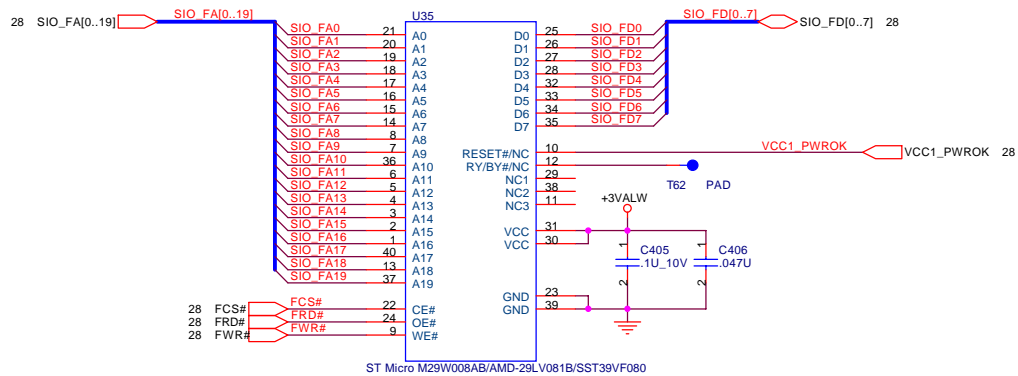

ST Micro M29W008AB/AMD-29LV081B/SST39VF080

**AMD :Pin 10 is RESET# ; Pin12 is RY/BY#**  
**SST :Pin10,12 are NC**

- 1.AMD-29LV081B require MAX 500nS Tready for it's hardware reset.And MAX6326\_UR29 has >100mS reset timing.So we can tie it's reset# pin to +3VALW directly.
- 2.SIO has internal 20 mS delay of VCC1\_PWROK

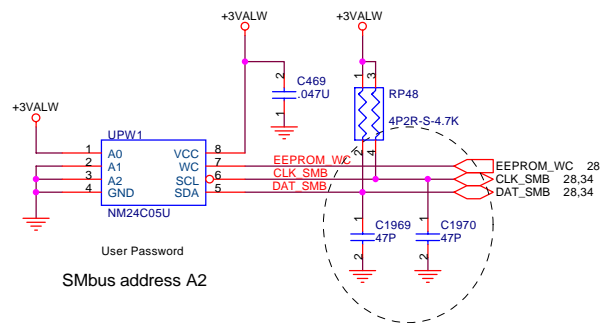

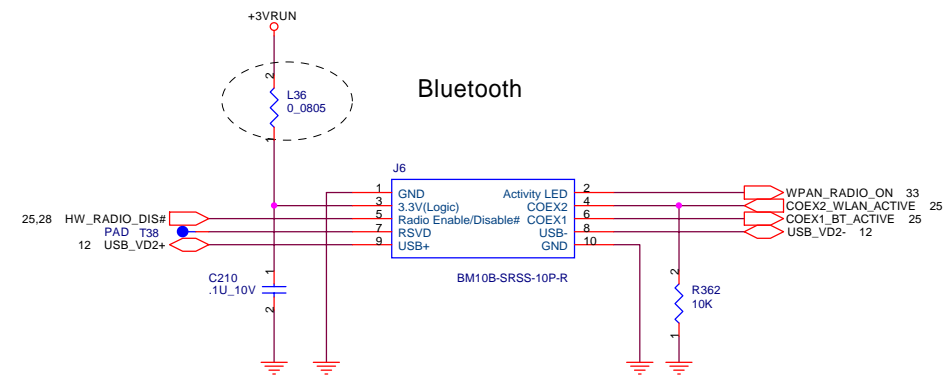
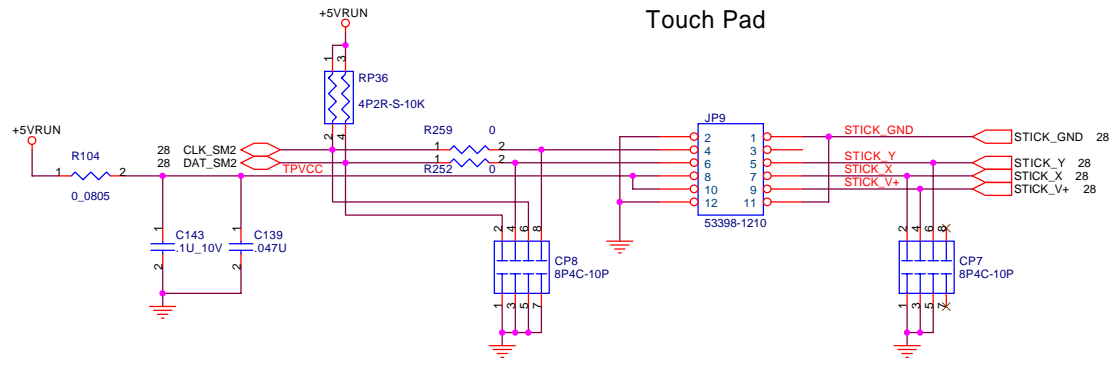

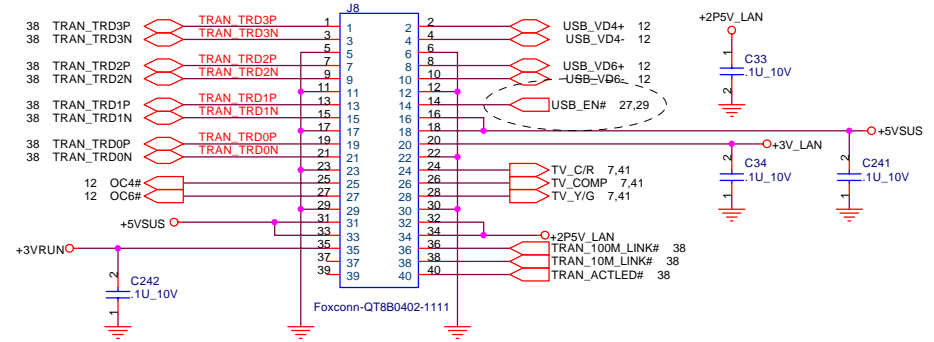
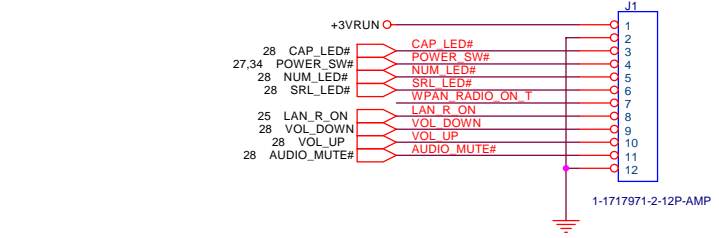
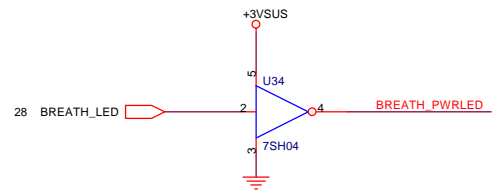
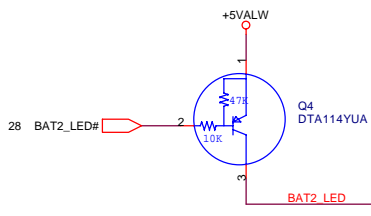
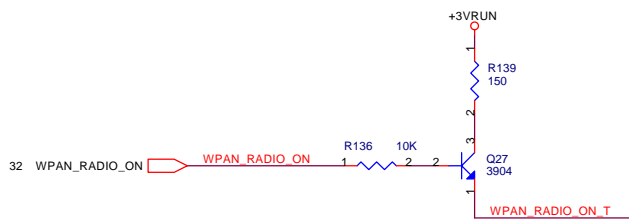
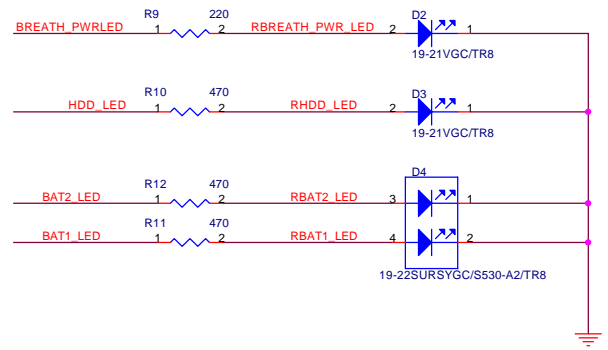
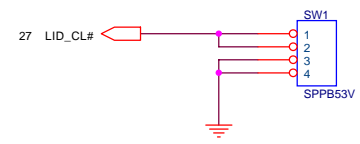
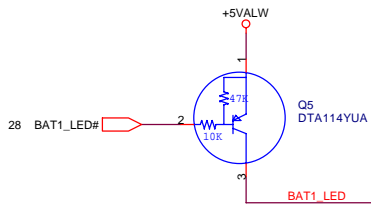
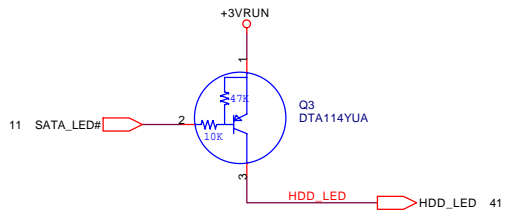



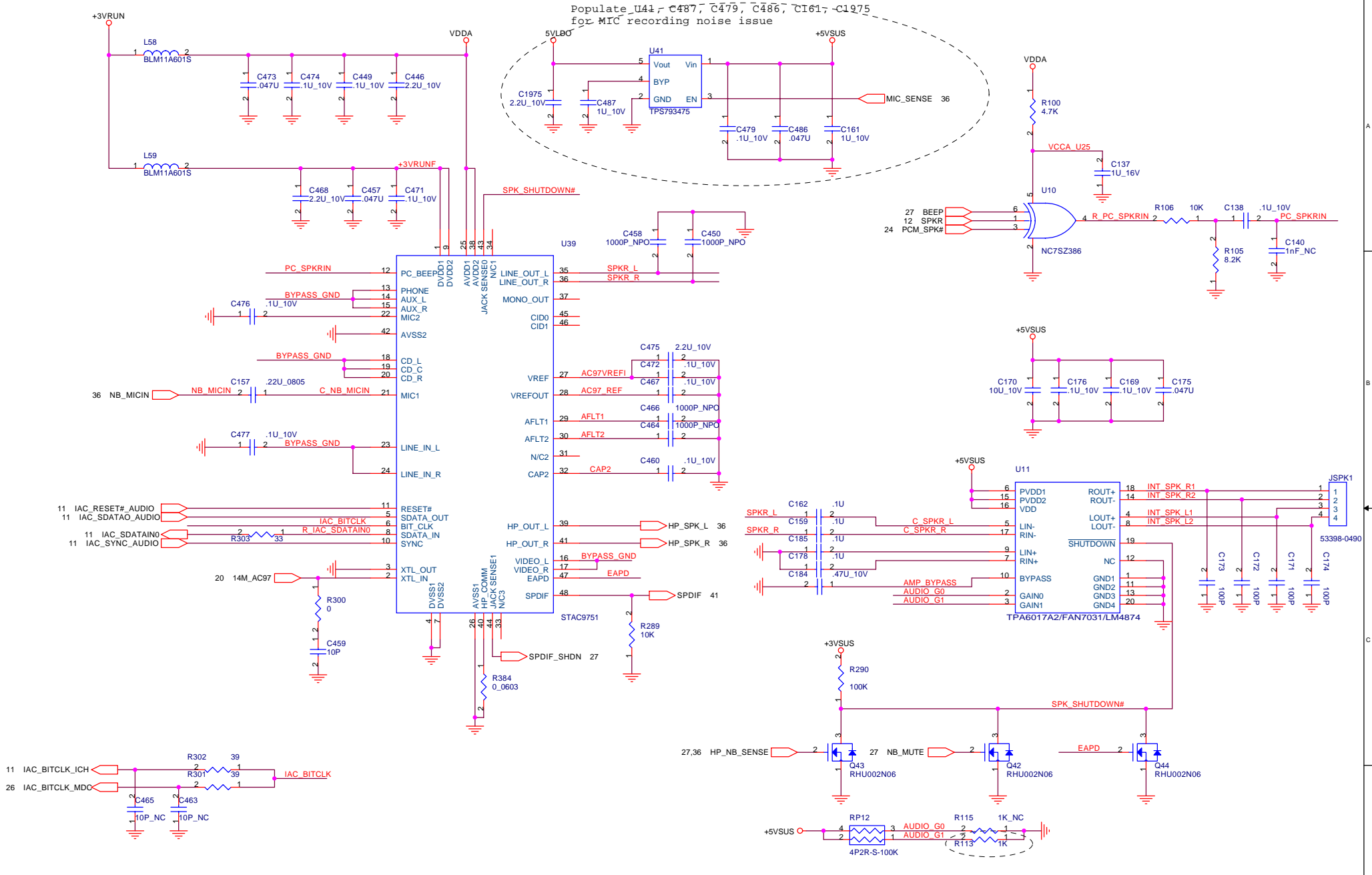

GAIN0	GAIN1	AV
0	0	6dB
0	1	10dB
1	0	15.6dB
1	1	21.6dB



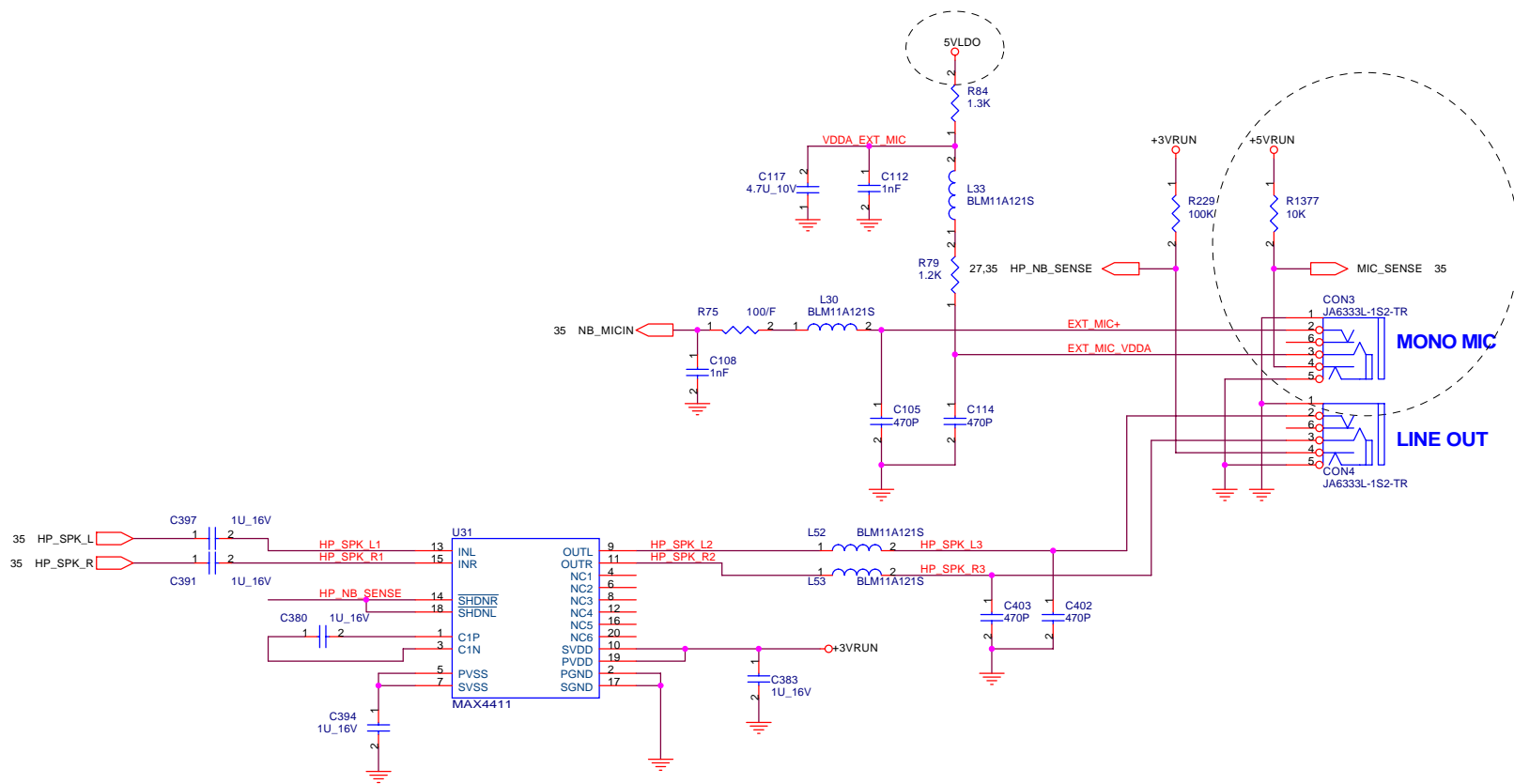

**QUANTA COMPUTER**

Title: AUDIO CONN

Size	Document Number JMSB	Rev 2A
------	-------------------------	-----------

Date: 星期五, 十月 29, 2004 Sheet 36 of 50

**U25**  
**BCM5751KFB**  
 15mm x 15mm  
**BGA196**

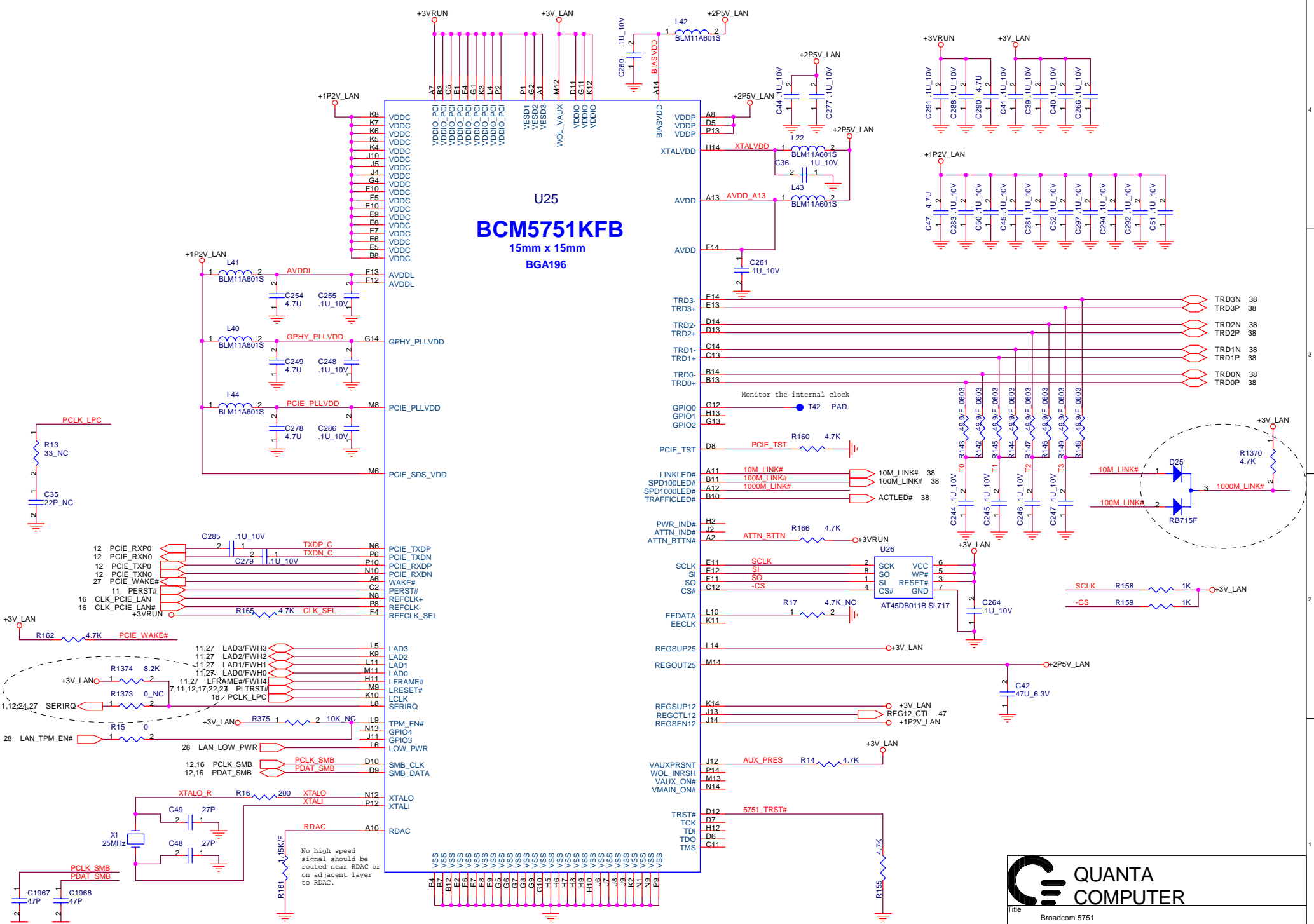

Title Broadcom 5751		
Size	Document Number JMSB	Rev 2A
Date:	星期四, 十月 29, 2004	Sheet 37 of 50

L14/L15/L16/L17/L18/L19/L20/L21 must be 0603

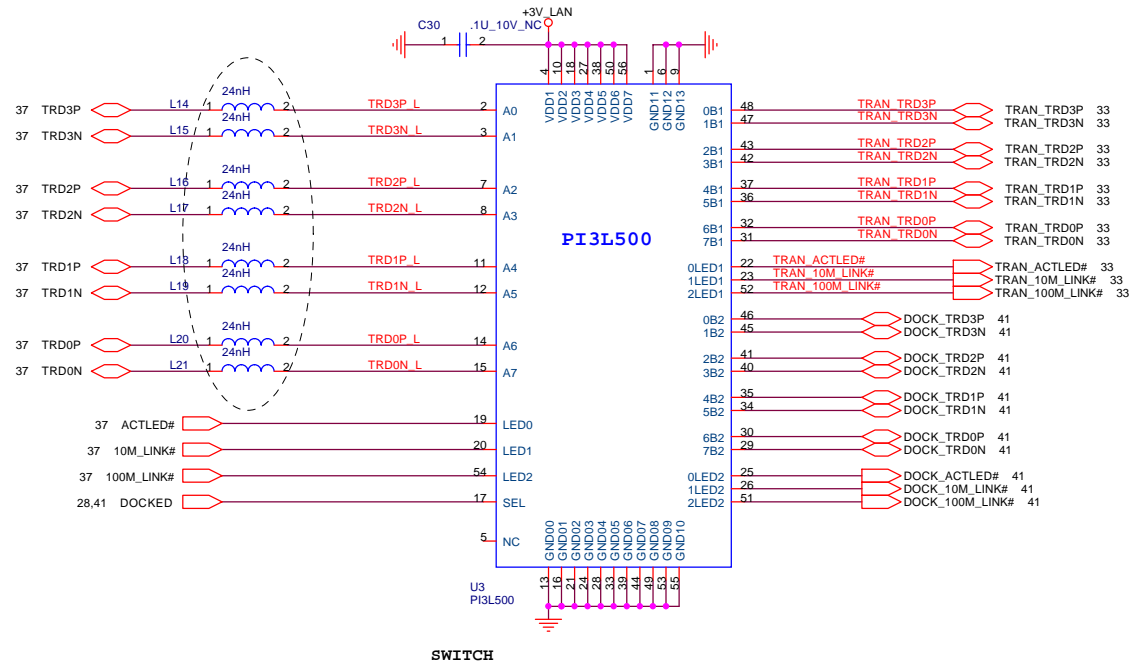

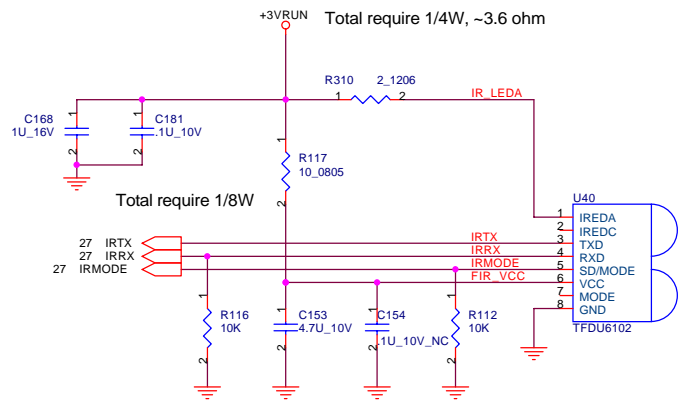

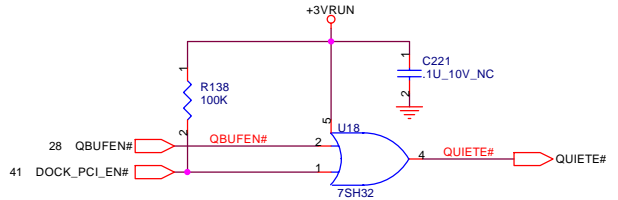
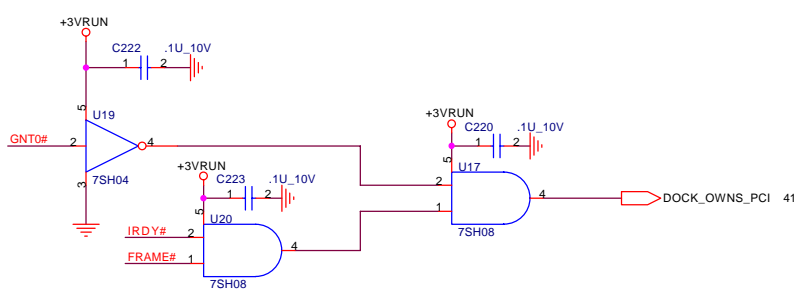
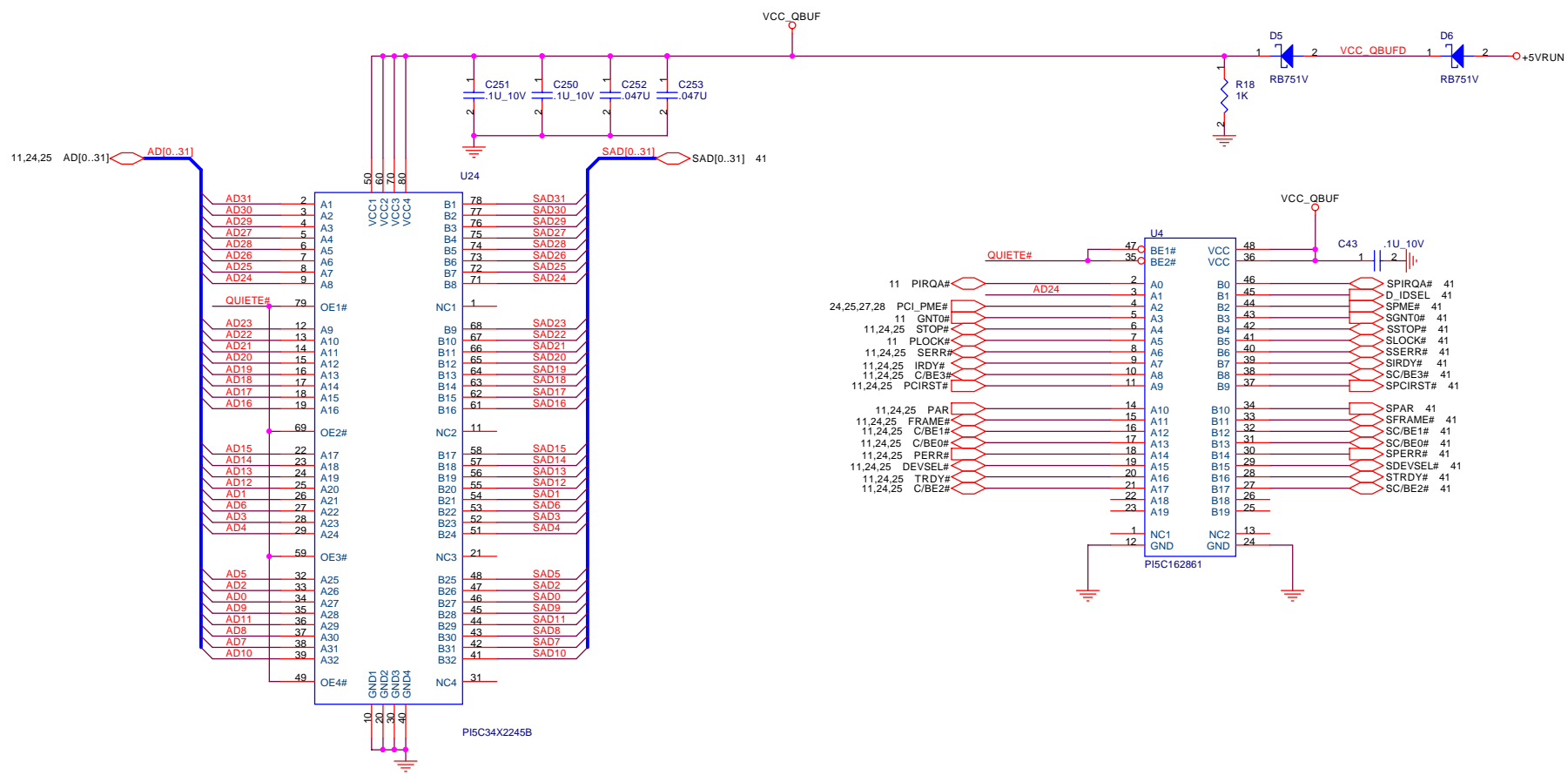

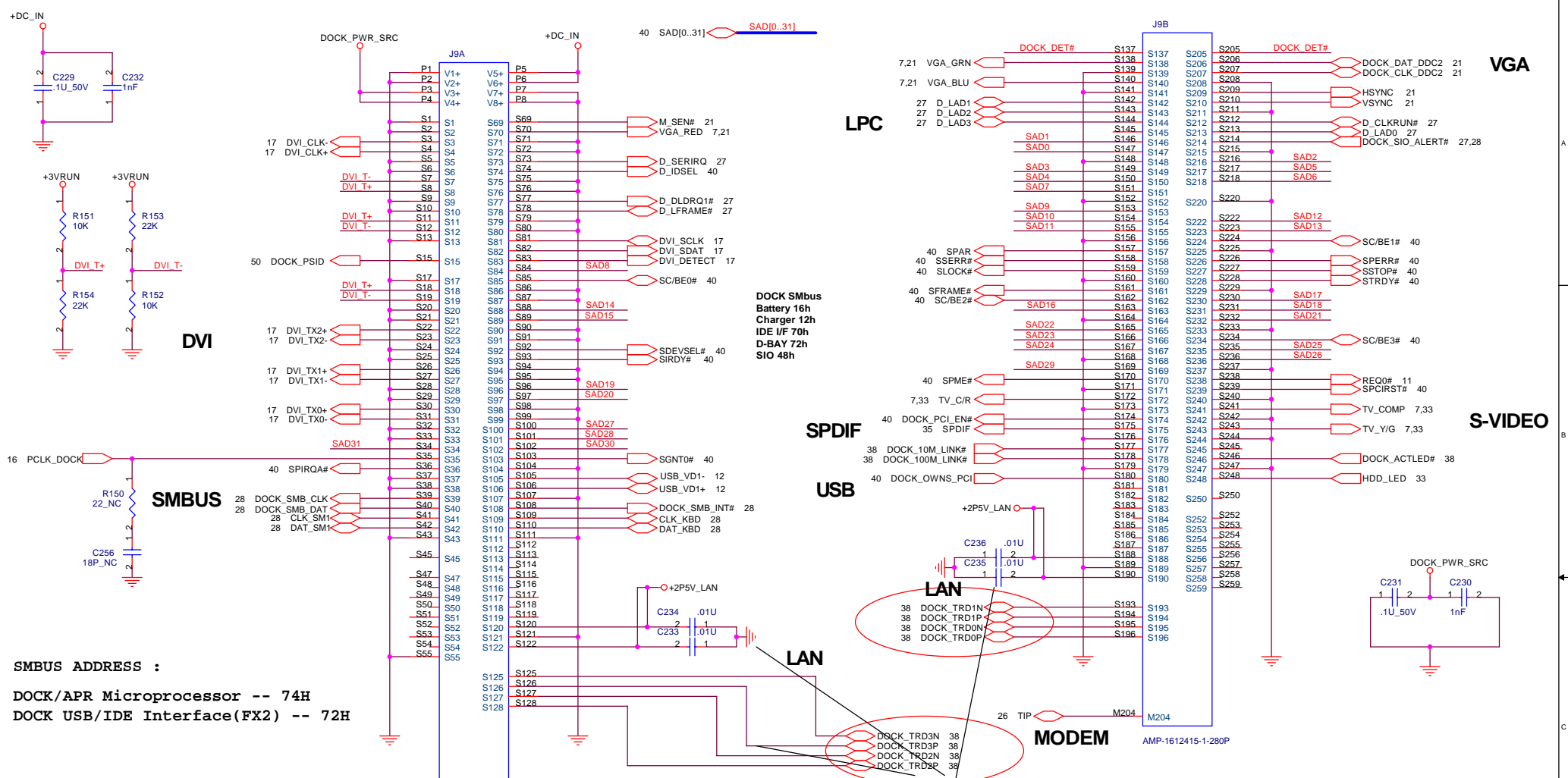

**SMBUS ADDRESS :**  
**DOCK/APR Microprocessor -- 74H**  
**DOCK USB/IDE Interface(FX2) -- 72H**

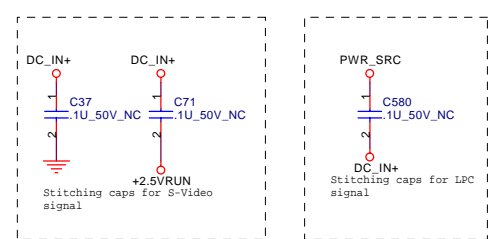
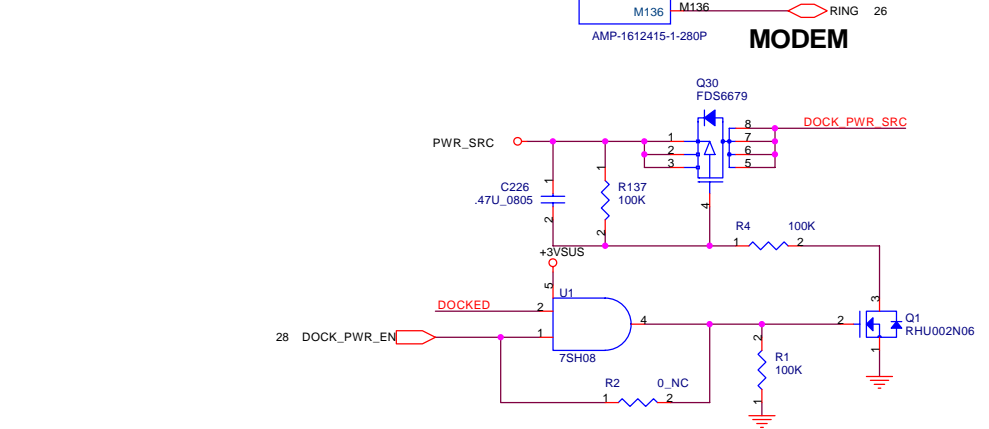

**QUANTA COMPUTER**

Title: Docking Station Conn.

Size	Document Number JMSB	Rev 2A
------	-------------------------	-----------

Date: 星期五, 十月 29, 2004 Sheet 41 of 50

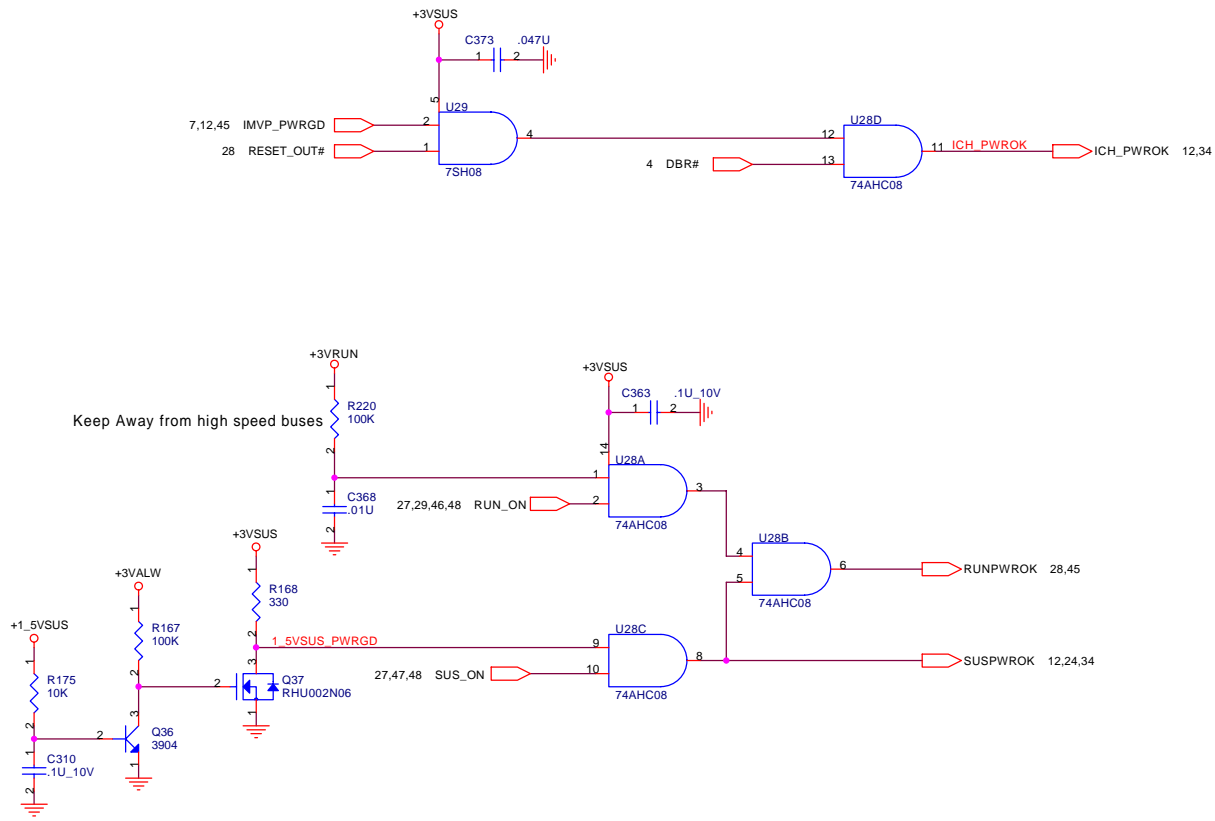



Connect GND side of PC134, PC135, PC131, PC129 and PC133 to GND through 1 via.

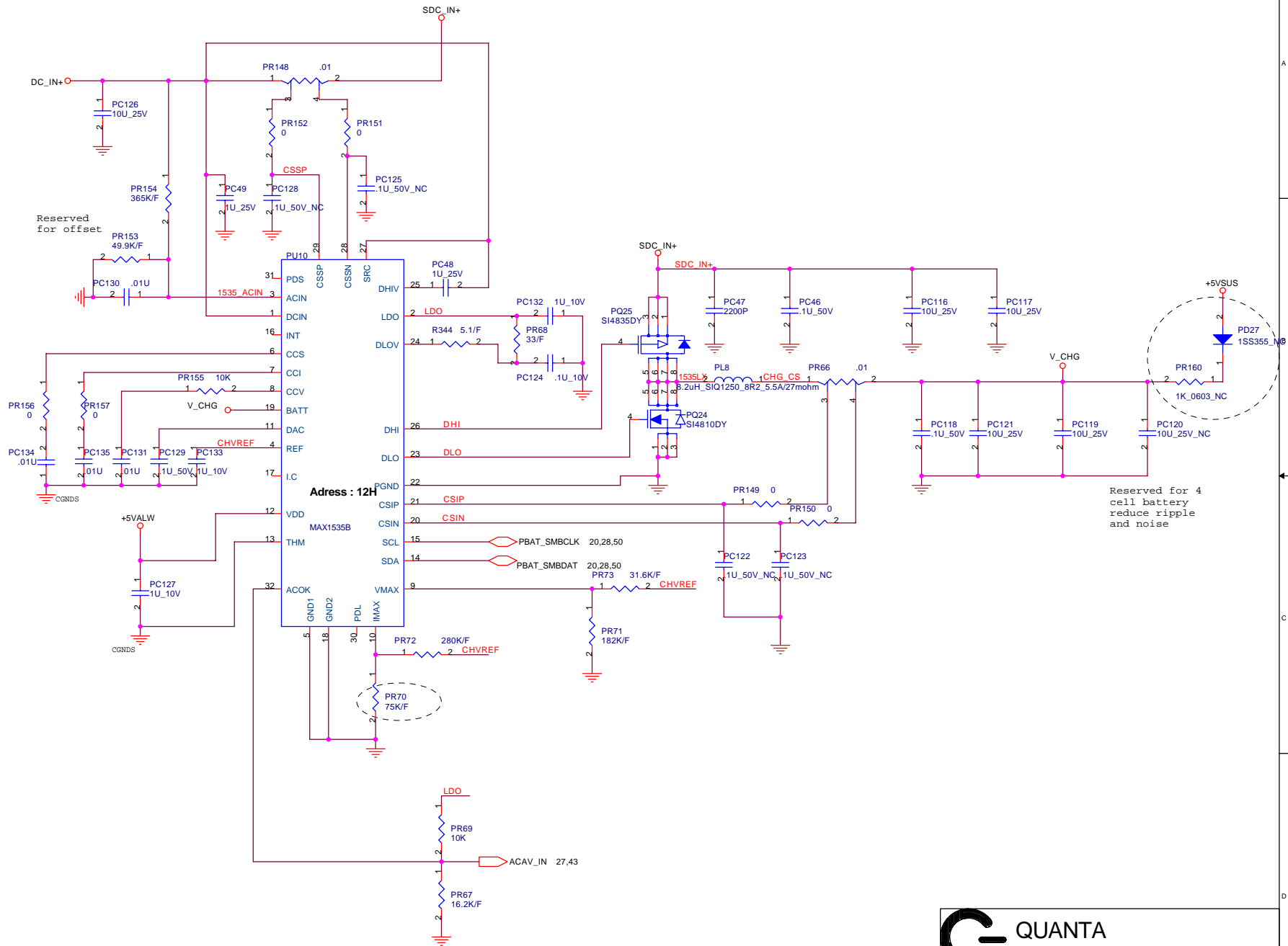

Reserved for 4 cell battery reduce ripple and noise

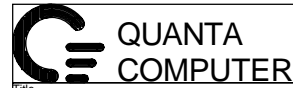

Title Battery Charger		
Size	Document Number JMSB	Rev 2A
Date:	星期五, 十月 29, 2004	Sheet 44 of 50

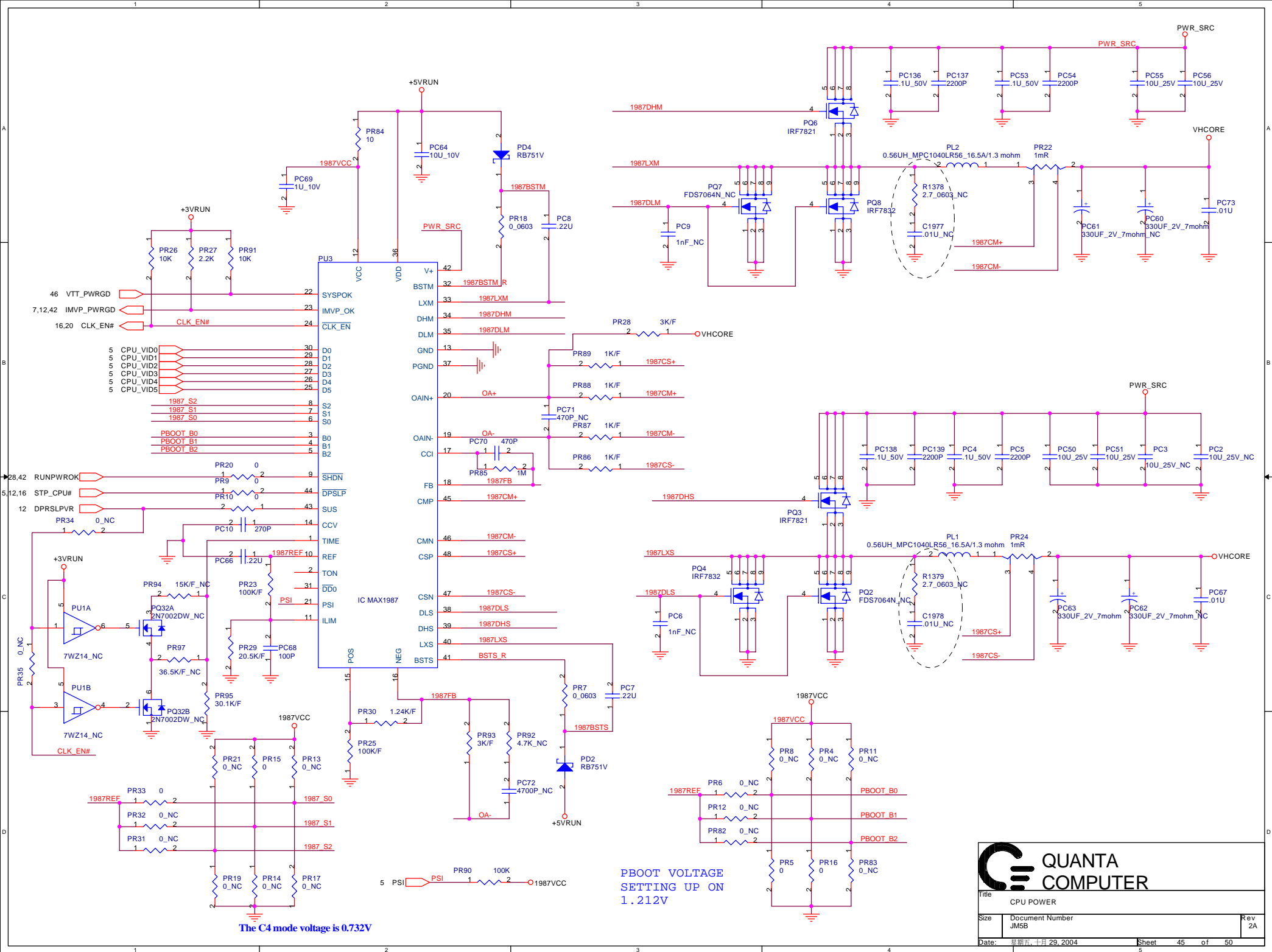

The C4 mode voltage is 0.732V

PBOOT VOLTAGE  
SETTING UP ON  
1.212V



Title CPU POWER		
Size	Document Number JMSB	Rev 2A
Date:	星期三, 十月 29, 2004	Sheet 45 of 50

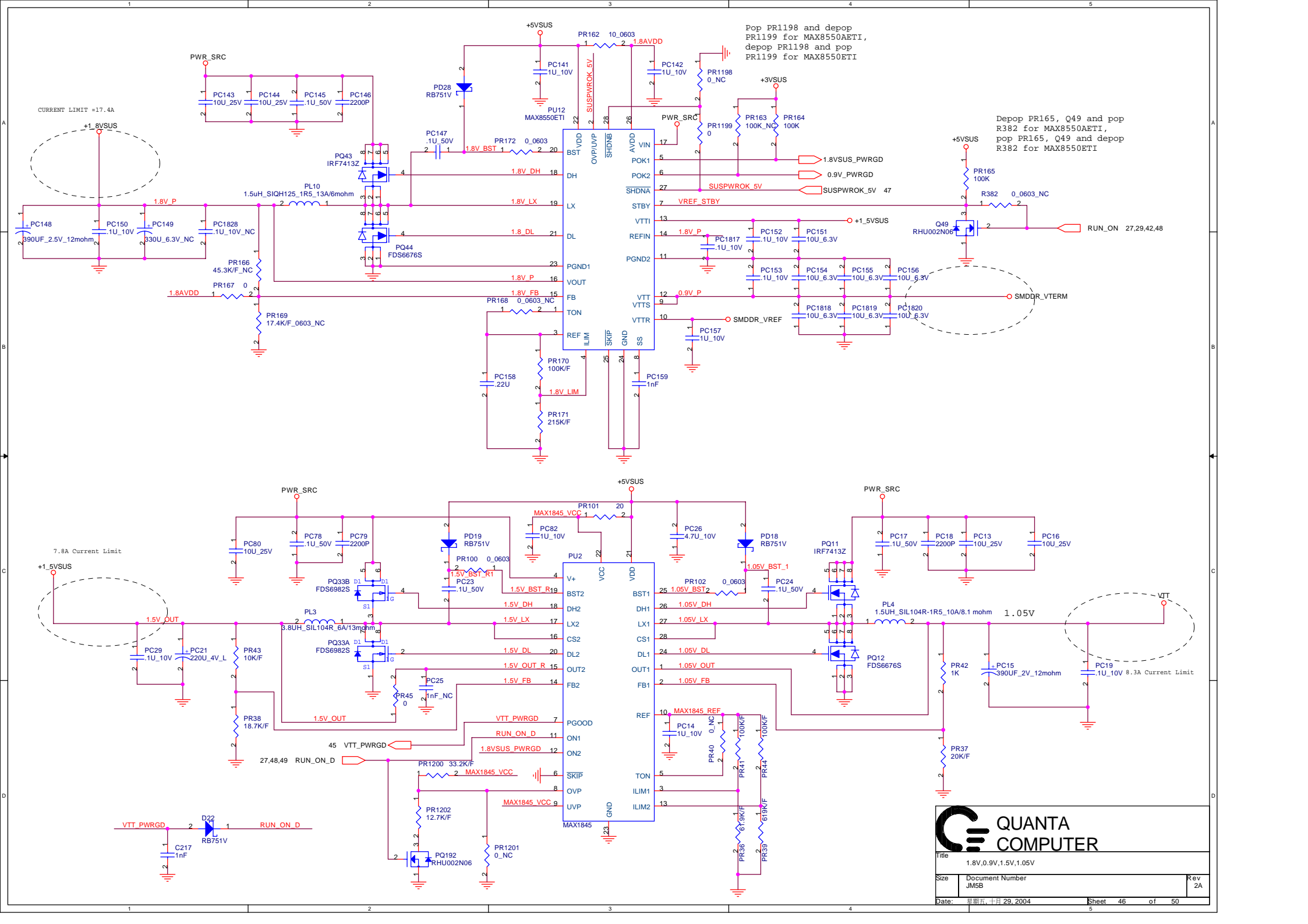

Pop PR1198 and depop PR1199 for MAX8550AETI, depop PR1198 and pop PR1199 for MAX8550ETI

Depop PR165, Q49 and pop R382 for MAX8550AETI, pop PR165, Q49 and depop R382 for MAX8550ETI



Title		
1.8V,0.9V,1.5V,1.05V		
Size	Document Number	Rev
JMSB		2A
Date:	星期三, 十月 29, 2004	Sheet 46 of 50

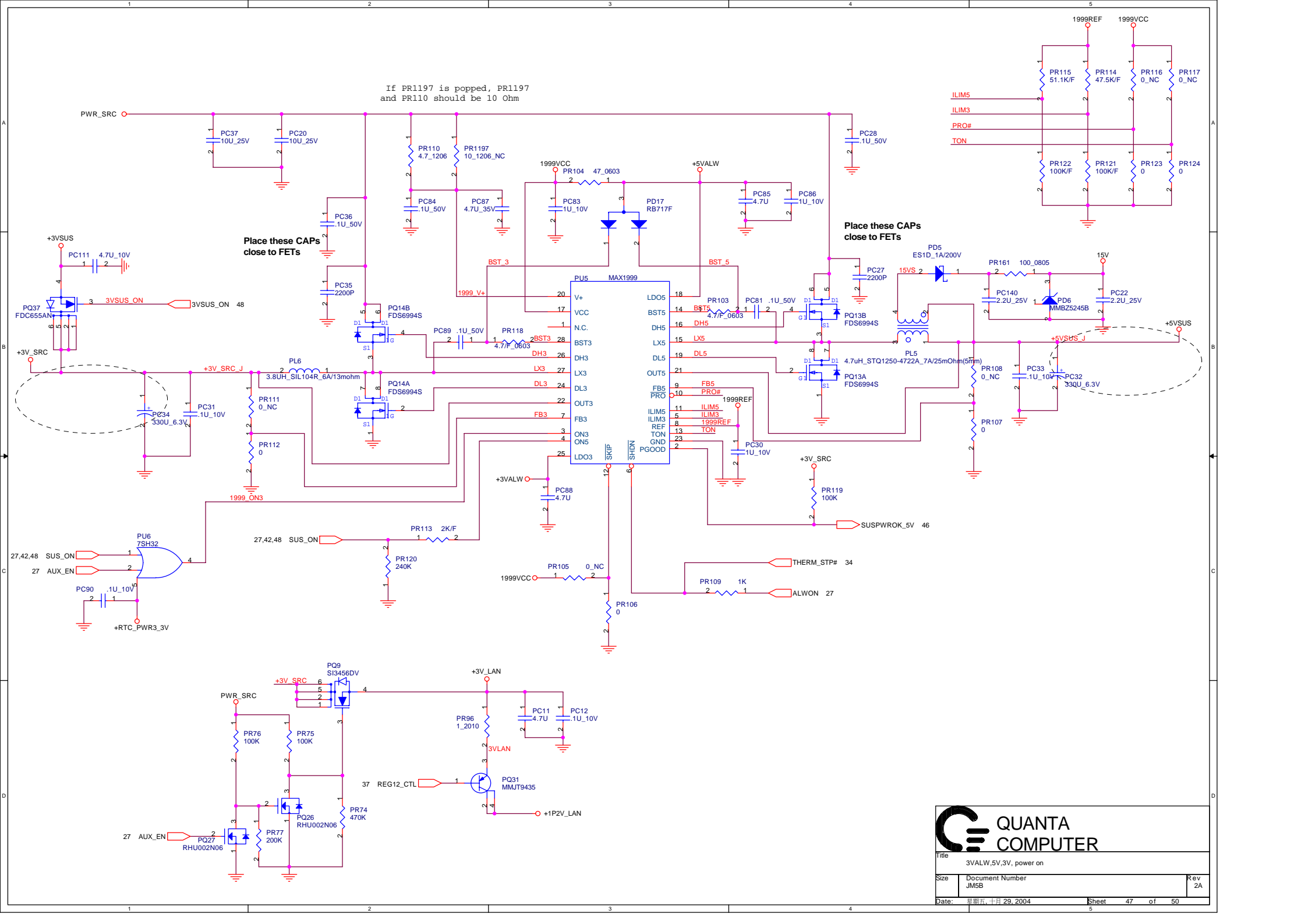

If PR1197 is popped, PR1197  
and PR110 should be 10 Ohm

Place these CAPs  
close to FETs

Place these CAPs  
close to FETs



Title 3VALW.5V.3V, power on		
Size	Document Number JMSB	Rev 2A
Date:	星期五, 十月 29, 2004	Sheet 47 of 50

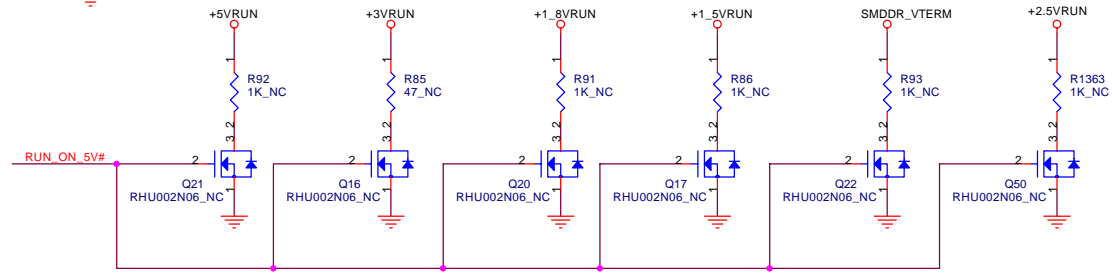
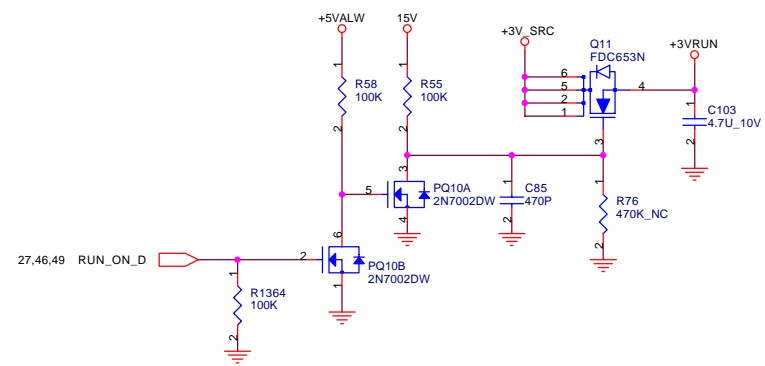
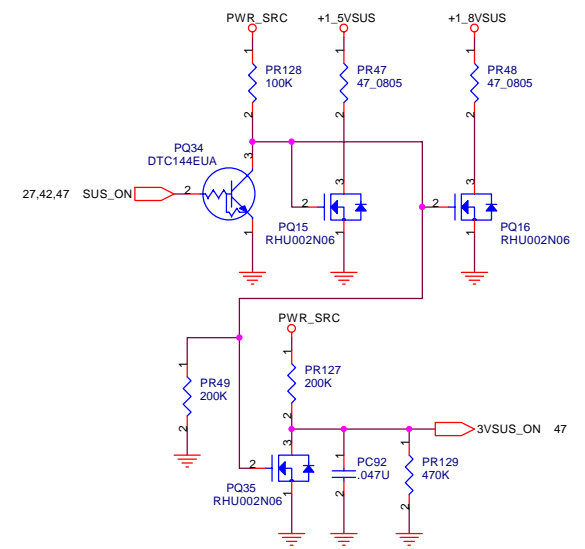
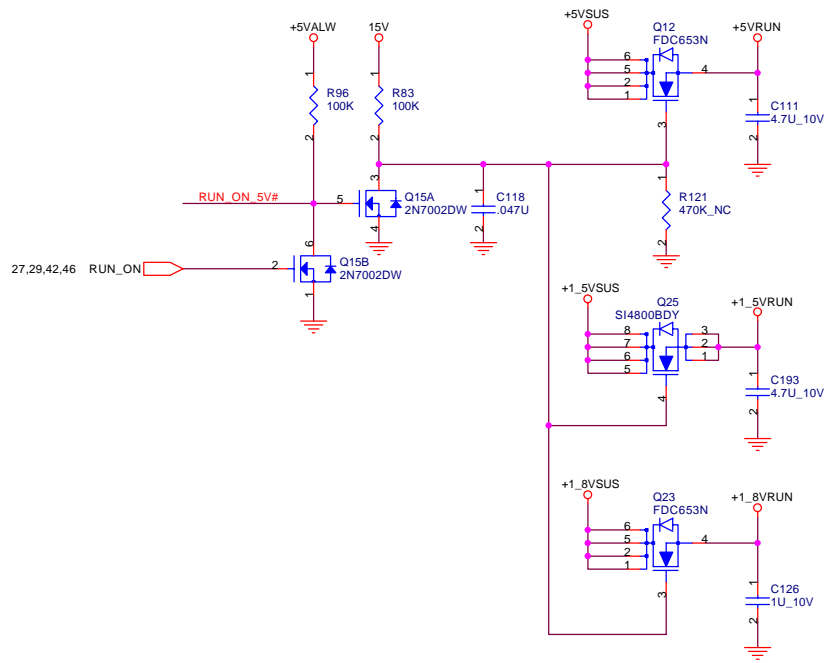

Reserve discharge path

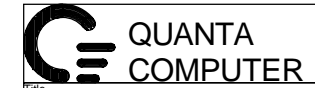

Title RUN POWER SW		
Size	Document Number JMSB	Rev 2A
Date:	星期五, 十月 29, 2004	Sheet 48 of 50

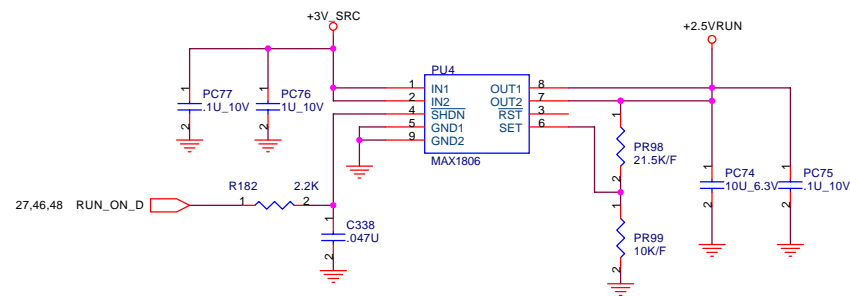

Title		
VGA DC/DC		
Size	Document Number	Rev
JMSB		2A
Date:	星期五, 十月 29, 2004	Sheet 49 of 50

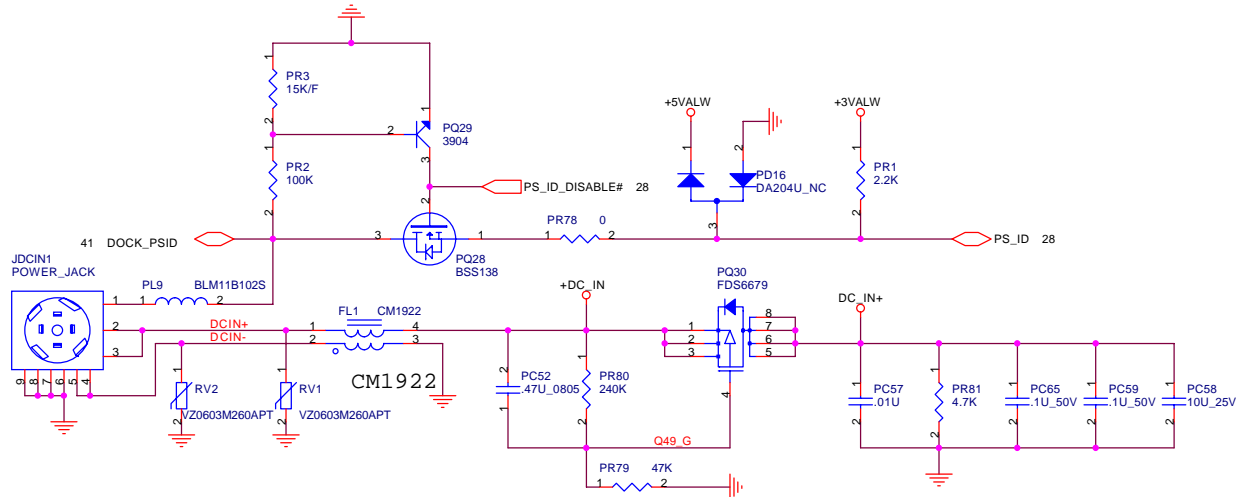
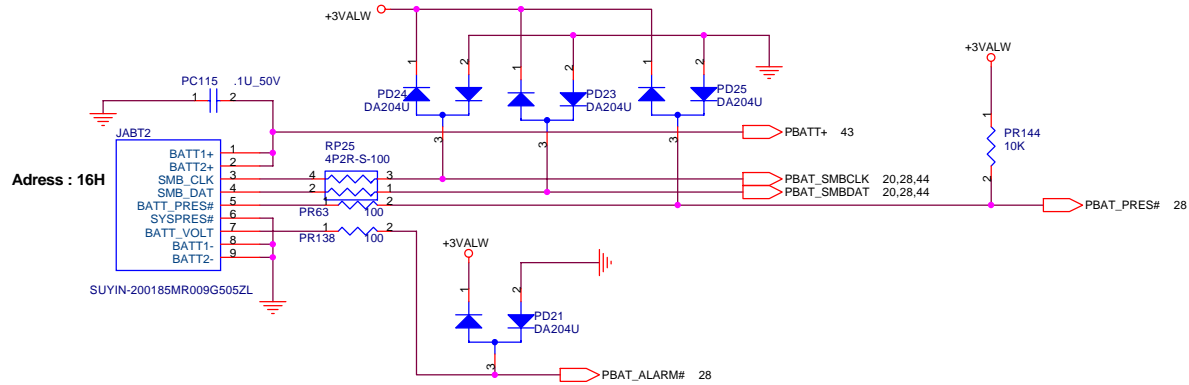
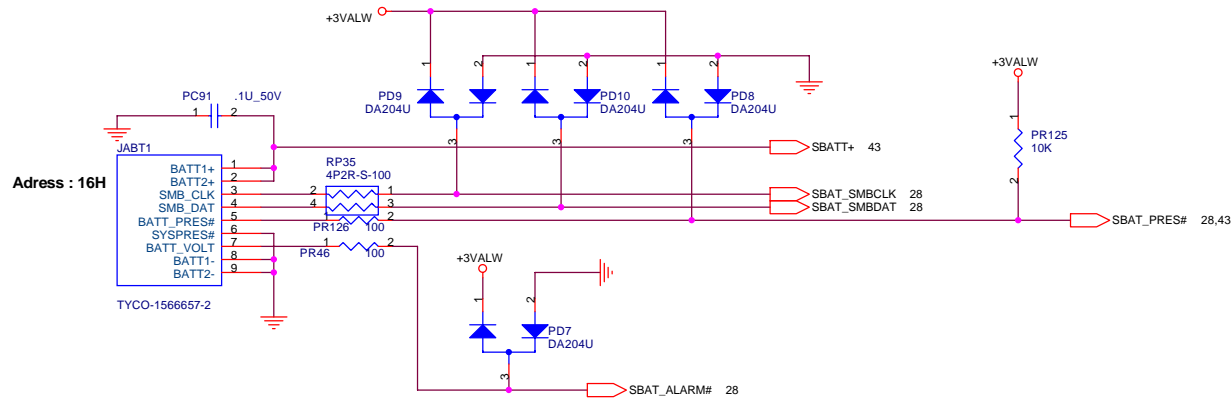

Title DCIN,BATT CONNECTOR		
Size	Document Number JMSB	Rev 2A
Date:	星期五, 十月 29, 2004	Sheet 50 of 50