

# Compal Confidential

## VAWGA/B Schematics Document

### AMD "Kabini" Platform

### AMD 25W APU With Jaguar Core and Integrated Yangtze FCH + ATI Sun

LA-9912P REV: 1.0

2013-04-01

Security Classification	Compal Secret Data			Compal Electronics, Inc.	
Issued Date	2012/04/22	Deciphered Date	2015/04/22	Title	COVER PAGE
THIS SHEET OF ENGINEERING DRAWING IS THE PROPRIETARY PROPERTY OF COMPAL ELECTRONICS, INC. AND CONTAINS CONFIDENTIAL AND TRADE SECRET INFORMATION. THIS SHEET MAY NOT BE TRANSFERRED FROM THE CUSTODY OF THE COMPETENT DIVISION OF PRODUCT DEVELOPMENT DEPARTMENT EXCEPT AS AUTHORIZED BY COMPAL ELECTRONICS, INC. NEITHER THIS SHEET NOR THE INFORMATION IT CONTAINS MAY BE USED BY OR DISCLOSED TO ANY THIRD PARTY WITHOUT PRIOR WRITTEN CONSENT OF COMPAL ELECTRONICS, INC.				Document Number	Rev
				VAWGA/GB	1.0
				Date: Monday, April 01, 2013	Sheet 1 of 37

# AMD Kabini

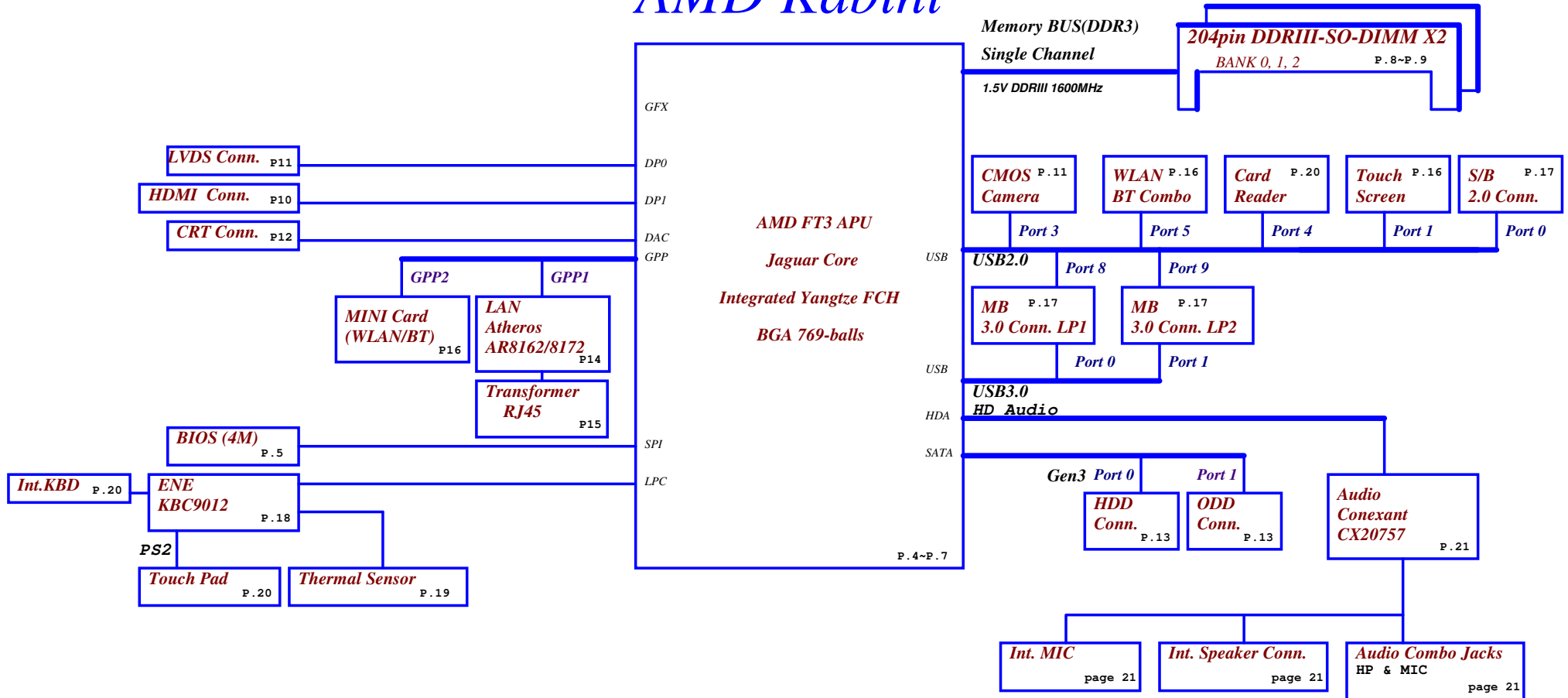

**Sub-board**

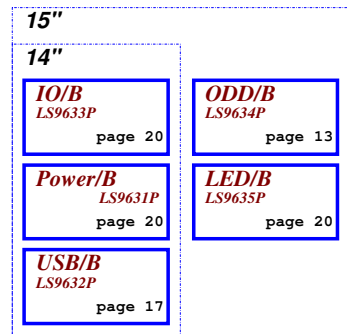

Security Classification	Compal Secret Data			Compal Electronics, Inc.		
Issued Date	2012/04/22	Deciphered Date	2015/04/22	Title	BLOCK DIAGRAMS	
THIS SHEET OF ENGINEERING DRAWING IS THE PROPRIETARY PROPERTY OF COMPAL ELECTRONICS, INC. AND CONTAINS CONFIDENTIAL AND TRADE SECRET INFORMATION. THIS SHEET MAY NOT BE TRANSFERRED FROM THE CUSTODY OF THE COMPETENT DIVISION OF PRODUCT DEVELOPMENT EXCEPT AS AUTHORIZED BY COMPAL ELECTRONICS, INC. NEITHER THIS SHEET NOR THE INFORMATION IT CONTAINS MAY BE USED BY OR DISCLOSED TO ANY THIRD PARTY WITHOUT PRIOR WRITTEN CONSENT OF COMPAL ELECTRONICS, INC.				Document Number	VAWGA/GB	
				Date	Thursday, March 28, 2013	Rev 1.0
				Page	2	of 37

### Voltage Rails

Power Plane	Description	S0	S3	S5
VIN	Adapter power supply (19V)	ON	ON	ON
B+	AC or battery power rail for power circuit.	ON	ON	ON
+APU_CORE	Core voltage for APU	ON	OFF	OFF
+APU_CORE_NB	Voltage for On-die VGA of APU	ON	OFF	OFF
+VGA_CORE	0.95-1.2V switched power rail	ON	OFF	OFF
+VDDCI	0.95-1.2V switched power rail	ON	OFF	OFF
+3VALW	3.3V always on power rail	ON	ON	OFF
+3VS	3.3V switched power rail	ON	OFF	OFF
+1.8VALW	1.8V always on power rail	ON	ON	ON*
+1.8VS	1.8V switched power rail	ON	OFF	OFF
+0.95VALW	0.95V always on power rail	ON	OFF	OFF
+0.95VS	0.95V switched power rail	ON	OFF	OFF
+1.5V	1.5V power rail for APU and DDR	ON	ON	OFF
+1.5VS	1.5V switched power rail	ON	OFF	OFF
+3VGS	3.3V switched power rail for VGA	ON	OFF	OFF
+1.8VGS	1.8V switched power rail for VGA	ON	OFF	OFF
+1.5VGS	1.5V switched power rail for VGA	ON	OFF	OFF
+0.95VGS	0.95V switched power rail for VGA	ON	OFF	OFF
+5VALW	5V always on power rail	ON	ON	ON
+5VS	5V switched power rail	ON	OFF	OFF
+VSB	VSB always on power rail	ON	ON	ON
+RTC_APU	RTC power	ON	ON	ON
+0.75VS	0.75V switched power rail for DDR terminator	ON	OFF	OFF

### BOARD ID Table

Board ID	PCB Revision
0	MP
1	PVT
2	DVT
3	EVT
4	
5	
6	
7	

STATE	SIGNAL	SLP_S3#	SLP_S5#	+VALW	+V	+VS	Clock
Full ON		HIGH	HIGH	ON	ON	ON	ON
S1 (Power On Suspend)		HIGH	HIGH	ON	ON	ON	LOW
S3 (Suspend to RAM)		HIGH	HIGH	ON	ON	OFF	OFF
S4 (Suspend to Disk)		LOW	HIGH	ON	OFF	OFF	OFF
S5 (Soft OFF)		LOW	LOW	ON	OFF	OFF	OFF

### Board ID / SKU ID Table for AD channel

Vcc	3.3V +/- 5%				
R1562	100K +/- 5%				
Board ID	R1564	VAD_BID min	VAD_BID typ	VAD_BID max	
0	0	0 V	0 V	0 V	
1	8.2K +/- 5%	0.216 V	0.250 V	0.289 V	
2	18K +/- 5%	0.436 V	0.503 V	0.538 V	
3	33K +/- 5%	0.712 V	0.819 V	0.875 V	
4	56K +/- 5%	1.036 V	1.185 V	1.264 V	
5	100K +/- 5%	1.453 V	1.650 V	1.759 V	
6	200K +/- 5%	1.935 V	2.200 V	2.341 V	
7	NC	2.500 V	3.300 V	3.300 V	

### USB OC MAPPING

OC#	USB Port	
0	USB20 port0	
1	USB20 port1,2,8,9	USB30 port0,1
2		
3		

### BOM Structure Table

BOM Structure	BTO Item
A6@	A6 R3 BGA APU
A4@	A4 R3 BGA APU
E2@	E2 R3 BGA APU
E1@	E1 R3 BGA APU
E1PC@	E1 PC BGA APU
X4@	X4 ES2 BGA APU
X5@	X5 ES2 BGA APU
X2@	X2 ES2 BGA APU
EMICU@	CardReader EMI Un pop
EMICP@	CardReader EMI pop
EMIUSB2RU@	Right USB2.0 port EMI un pop
EMIUSB2RP@	Right USB2.0 port EMI pop
USB2R@	Right USB2.0 port component
SUN@	SUN PRO GPU (R3 compal part)
MARS@	MARS XT GPU (R1 compal part)
14@	for 14" component
15@	for 15" component
PX@	Common VGA circuit
CMOS@	CMOS Camera part
HDMI@	HDMI part
EMIGASP@	Gastube
8162@	Ateros AR8162 LAN Chip
8172@	Ateros AR8172 LAN Chip
SWR@	LAN Switching mode
LDO@	LAN LDO mode
THERMAL@	Lenovo Thermal Sensor
ME@	ME part
UMA@	UMA part
@	Unpop
ZODD@	Zero Power ODD part
TS@	Touch Screen
EMIP@	EMI pop component
EMIU@	EMI Un pop component
ESDP@	ESD pop component
ESDU@	ESD Un pop component

### APU PCIE PORT LIST

Port	Device
0	
1	LAN
2	WLAN
3	

### USB Port Table

USB 2.0	USB 3.0	Port	3 External USB Port
		0	RIGHT USB
		1	Touch Screen
		2	
		3	Camera
		4	CardReader
		5	WLAN/BT Combo
		6	LEFT USB (for colay)
		7	LEFT USB (for colay)
		8	LEFT USB3.0
	XHCI	1	LEFT USB3.0

### SMBUS Control Table

	SOURCE	VGA	BATT	KB9012	SODIMM	WLAN WWAN	Thermal Sensor	FCH	APU	RTD2132
SMB_EC_CK1 SMB_EC_DA1	KB9012 +3VALW	X	V +3VALW	X	X	X	X	X	X	X
APU_SCLK0 APU_SDATA0	APU +3VS	X	X	X	V +3VS	V +3VS	X	X	X	X
SMB_EC_CK2 SMB_EC_DA2	KB9012 +3VS	V +3VS	X	X	X	X	V +3VS	X	V +3VS	X

EC SM Bus1 address			EC SM Bus2 address		
Device	Address	HEX	Device	Address	HEX
Smart Battery	0001 011X b	16H	Thermal Sensor	1001 101X b	9AH
			SB-TSI (APU)	1001 100X b	98H
			VGA Internal Thermal	1000 001X b	82H

### APU SM Bus address

Device	Address	HEX
DDR DIMM1	1010 000Xb	A0H
DDR DIMM2	1010 001Xb	A2H

Security Classification	Compal Secret Data		Title	
Issued Date	2012/04/22	Deciphered Date	2015/04/22	Compal Electronics, Inc.
<small>THIS SHEET OF ENGINEERING DRAWING IS THE PROPRIETARY PROPERTY OF COMPAL ELECTRONICS, INC. AND CONTAINS CONFIDENTIAL AND TRADE SECRET INFORMATION. THIS SHEET MAY NOT BE TRANSFERRED FROM THE CUSTODY OF THE COMPETENT DIVISION OF COMPAL ELECTRONICS, INC. NEITHER THIS SHEET NOR THE INFORMATION IT CONTAINS MAY BE USED BY OR DISCLOSED TO ANY THIRD PARTY WITHOUT PRIOR WRITTEN CONSENT OF COMPAL ELECTRONICS, INC.</small>				Document Number <b>VAWGA/GB</b> Date: Monday, April 01, 2013   Sheet 3 of 37





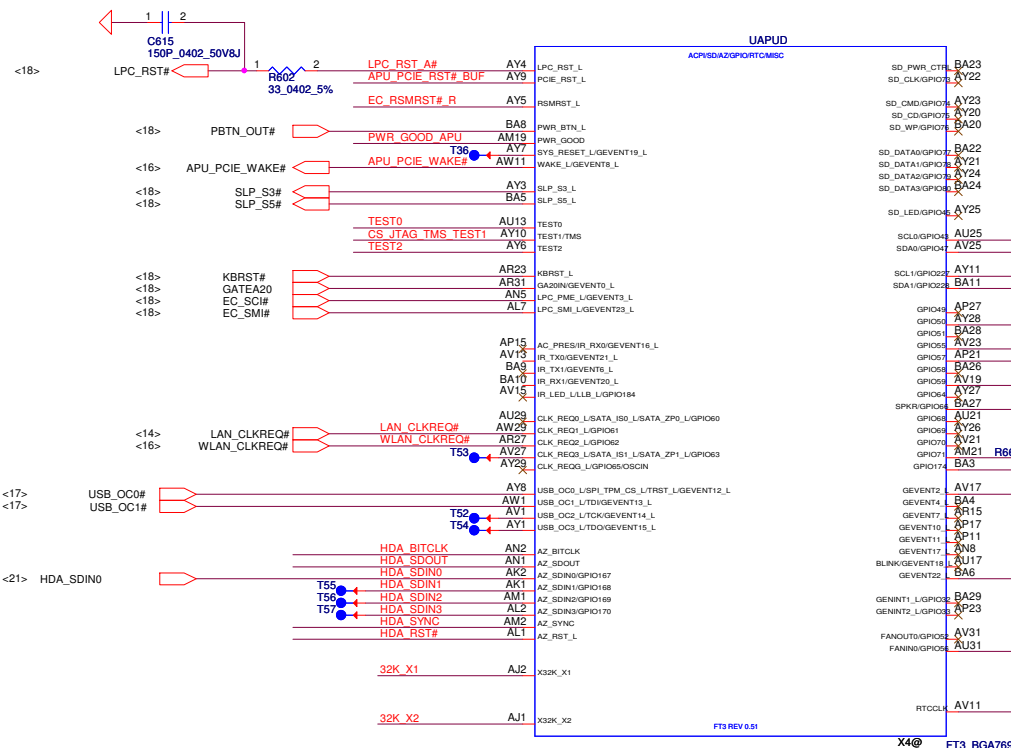

If use as SMBUS :  
 Pulled-up to VDD\_33(port0) , VDD\_33\_ALM(port1) with a resistor of:  
 Qty: 1; Value: 2.2 KΩ; Tol: 5%  
 If no use :  
 Pulled-up to VDD\_33(port0) , VDD\_33\_ALM(port1) with a resistor of:  
 Qty: 1; Value: 10 KΩ; Tol: 5%

Board ID1	Function
0	PX5.5
1	UMA

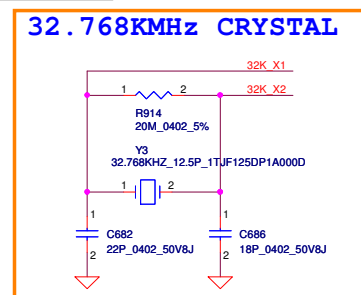

**PU +3VALW + PD**

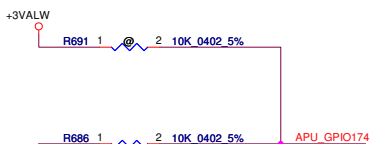

**PU +3VALW**

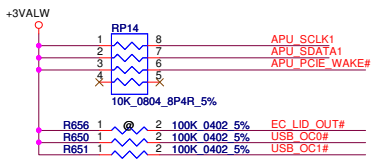

**PU +3VS**

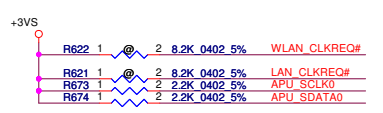

**PD**

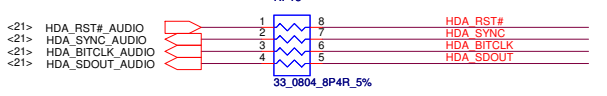
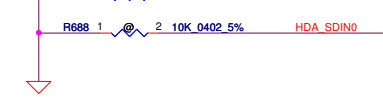

**EC\_RSMRST# , POWER\_GOOD follow CRB (APU side 1.8V power rail)**

Must connected to 10 ms RC delay circuit on +1.8-V 85 power rail.

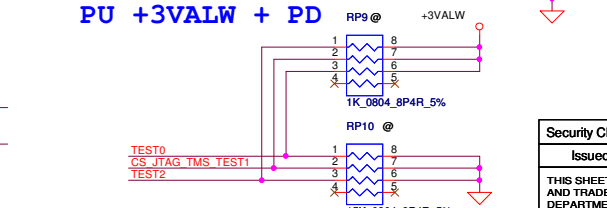
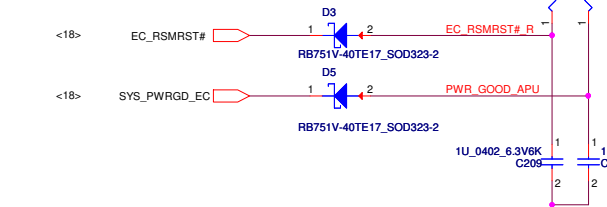

**STRAPS OF APU**

	LPC_FRAME#	LPC_CLK0_EC	LPC_CLK1	GEVENT2_L	RTC_CLK
H	SPI ROM (DEFAULT)	BOOT FAIL TIMER ENABLED	CLKGEN ENABLE (DEFAULT)	1.8V SPI ROM	NORMAL POWER UP/RESET TIMING (DEFAULT)
L	LPC ROM	BOOT FAIL TIMER DISABLED (DEFAULT)	CLKGEN DISABLED	3.3V SPI ROM (DEFAULT)	FAST POWER UP/RESET TIMING FOR SIMULATION

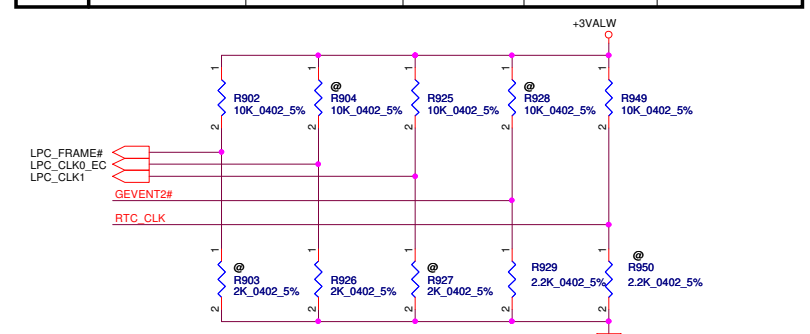





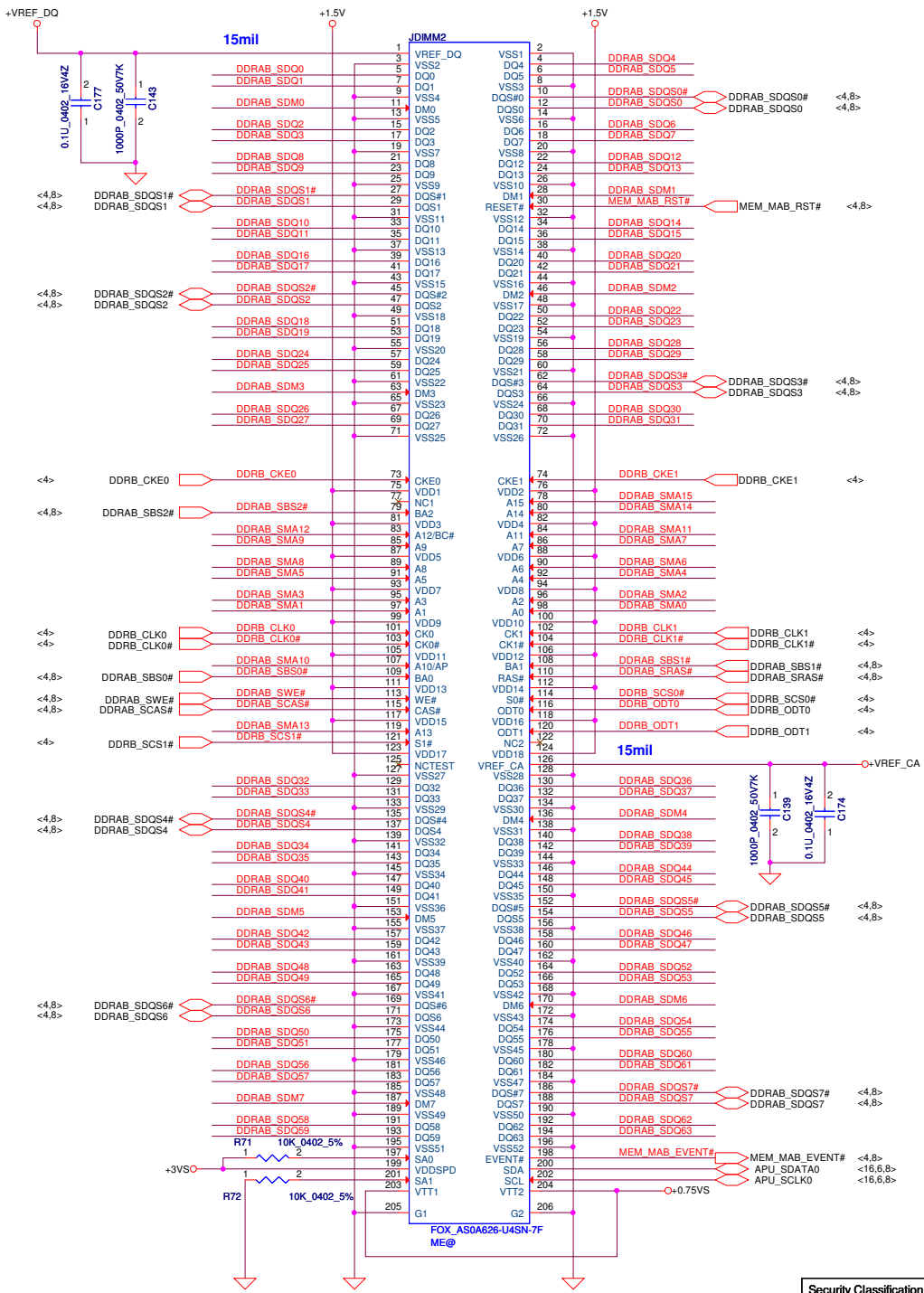

- DDRAB\_SDO[0..63]
- DDRAB\_SDM[0..7]
- DDRAB\_SMA[0..15]
- DDRAB\_SDO0#
- DDRAB\_SDO5#
- DDRAB\_SDO5#
- MEM\_MAB\_RST#

**+1.5V/+0.75VS OF DIMM2**

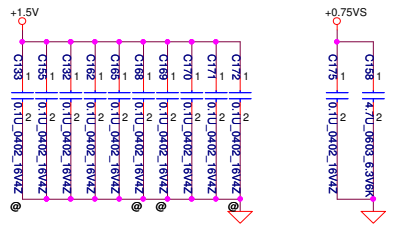

**DIMM\_B H:4mm**  
 <Address: 10>

Security Classification	Compal Secret Data		Compal Electronics, Inc.	
Issued Date	2012/04/22	Deciphered Date	2015/04/22	Title
THIS SHEET OF ENGINEERING DRAWING IS THE PROPRIETARY PROPERTY OF COMPAL ELECTRONICS, INC. AND CONTAINS CONFIDENTIAL AND TRADE SECRET INFORMATION. THIS SHEET MAY NOT BE TRANSFERRED FROM THE CUSTODY OF THE COMPETENT DIVISION OF PRODUCT DEVELOPMENT EXCEPT AS AUTHORIZED BY COMPAL ELECTRONICS, INC. NEITHER THIS SHEET NOR THE INFORMATION IT CONTAINS MAY BE USED BY OR DISCLOSED TO ANY THIRD PARTY WITHOUT PRIOR WRITTEN CONSENT OF COMPAL ELECTRONICS, INC.				Document Number <b>VAWGA/GB</b> Date: Thursday, March 28, 2013
				Rev 1.0
				Sheet 9 of 37

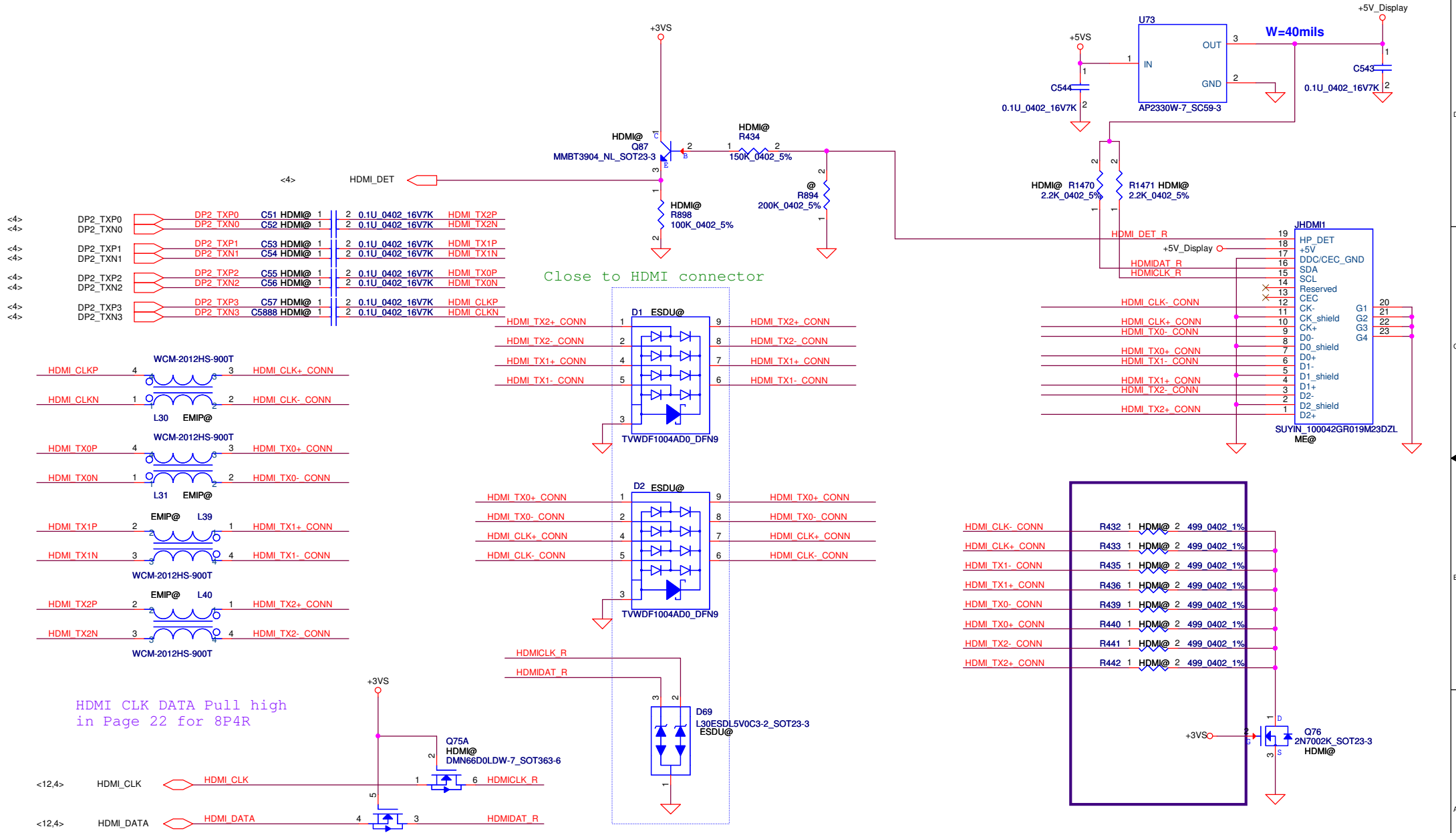

<4>	DP2_TXP0	DP2_TXN0	C51 HDMI@ 1	2	0.1U_0402_16V7K	HDMI_TX2P
<4>	DP2_TXP1	DP2_TXN1	C53 HDMI@ 1	2	0.1U_0402_16V7K	HDMI_TX1P
<4>	DP2_TXP2	DP2_TXN2	C55 HDMI@ 1	2	0.1U_0402_16V7K	HDMI_TX0P
<4>	DP2_TXP3	DP2_TXN3	C57 HDMI@ 1	2	0.1U_0402_16V7K	HDMI_CLKP

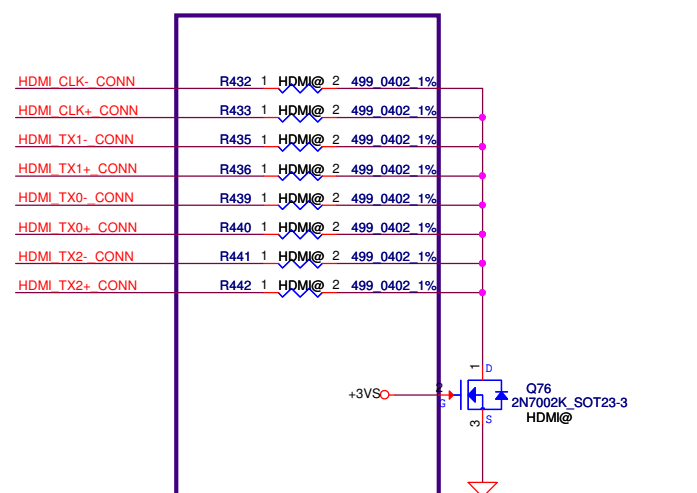
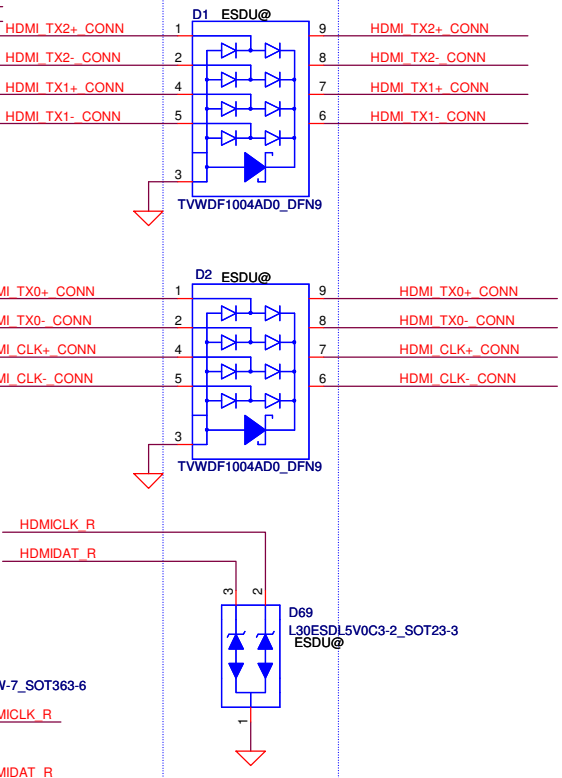
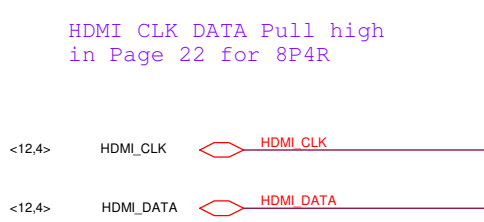
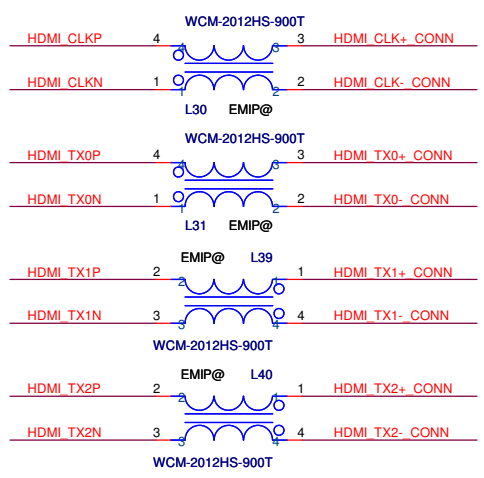

HDMI_CLK- CONN	R432	1	HDMI@	2	499_0402_1%
HDMI_CLK+ CONN	R433	1	HDMI@	2	499_0402_1%
HDMI_TX1- CONN	R435	1	HDMI@	2	499_0402_1%
HDMI_TX1+ CONN	R436	1	HDMI@	2	499_0402_1%
HDMI_TX0- CONN	R439	1	HDMI@	2	499_0402_1%
HDMI_TX0+ CONN	R440	1	HDMI@	2	499_0402_1%
HDMI_TX2- CONN	R441	1	HDMI@	2	499_0402_1%
HDMI_TX2+ CONN	R442	1	HDMI@	2	499_0402_1%

Security Classification	Compal Secret Data		Title		Compal Electronics, Inc.	
Issued Date	2012/04/22	Deciphered Date	2015/04/22	HDMI CONN		Rev
THIS SHEET OF ENGINEERING DRAWING IS THE PROPRIETARY PROPERTY OF COMPAL ELECTRONICS, INC. AND CONTAINS CONFIDENTIAL AND TRADE SECRET INFORMATION. THIS SHEET MAY NOT BE TRANSFERRED FROM THE CUSTODY OF THE COMPETENT DIVISION OF R&D DEPARTMENT EXCEPT AS AUTHORIZED BY COMPAL ELECTRONICS, INC. NEITHER THIS SHEET NOR THE INFORMATION IT CONTAINS MAY BE USED BY OR DISCLOSED TO ANY THIRD PARTY WITHOUT PRIOR WRITTEN CONSENT OF COMPAL ELECTRONICS, INC.				Document Number	VAWGA/GB	1.0
Date:	Monday, April 01, 2013	Sheet	10	of	37	

# LCD POWER CIRCUIT

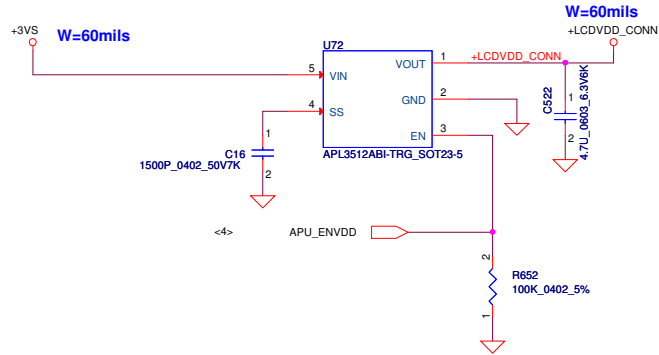

# CMOS Camera

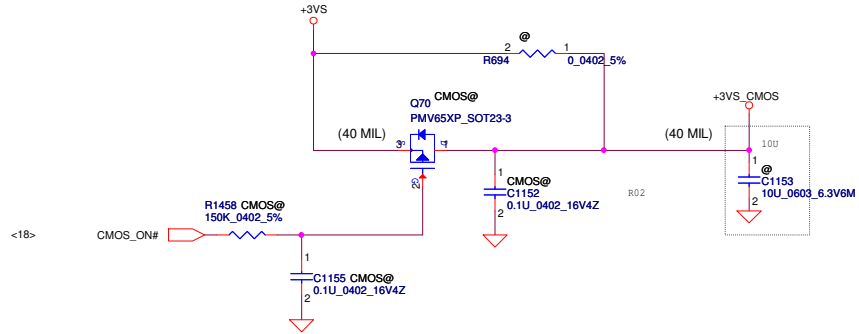

# VGA LCD/PANEL BD. Conn.

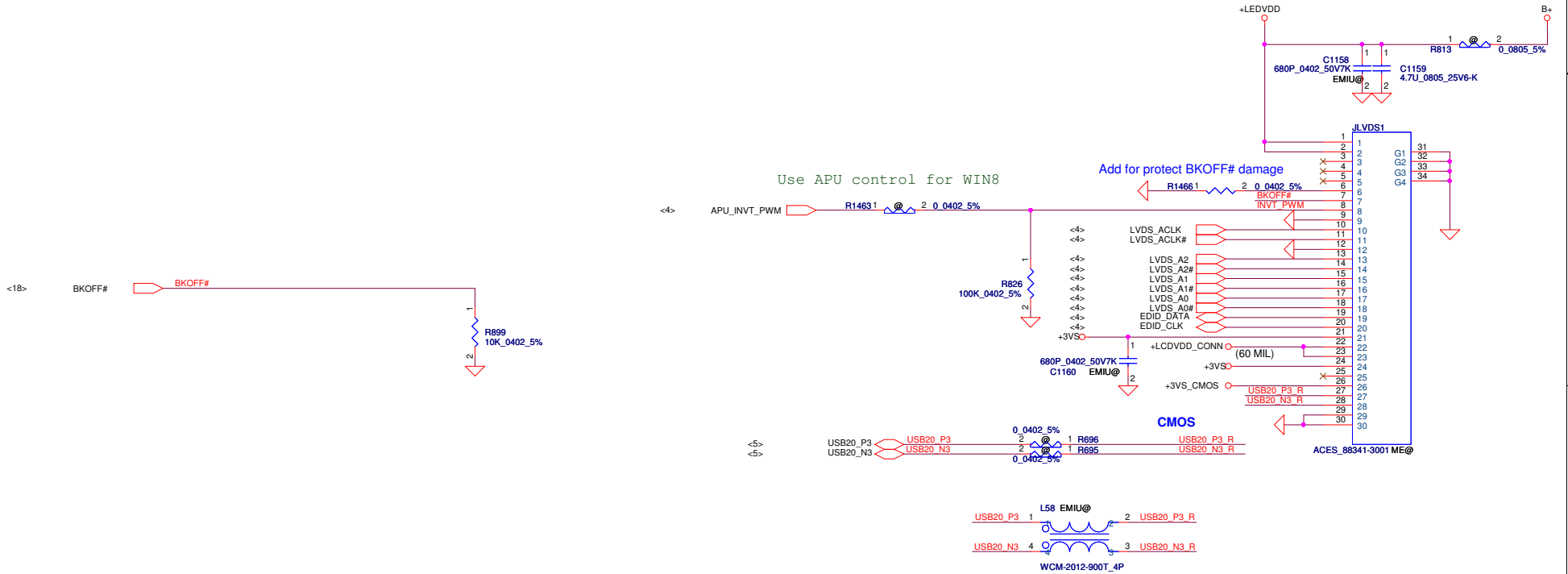

Security Classification	Compal Secret Data		Title	
Issued Date	2012/04/22	Deciphered Date	2015/04/22	Compal Electronics, Inc.
THIS SHEET OF ENGINEERING DRAWING IS THE PROPRIETARY PROPERTY OF COMPAL ELECTRONICS, INC. AND CONTAINS CONFIDENTIAL AND TRADE SECRET INFORMATION. THIS SHEET MAY NOT BE TRANSFERRED FROM THE CUSTODY OF THE COMPETENT DIVISION OF COMPAL ELECTRONICS, INC. DEPARTMENT EXCEPT AS AUTHORIZED BY COMPAL ELECTRONICS, INC. NEITHER THIS SHEET NOR THE INFORMATION IT CONTAINS MAY BE USED BY OR DISCLOSED TO ANY THIRD PARTY WITHOUT PRIOR WRITTEN CONSENT OF COMPAL ELECTRONICS, INC.				Document Number
				VAWGA/GB
				Rev 1.0
Date: Thursday, March 28, 2013				Sheet 11 of 37

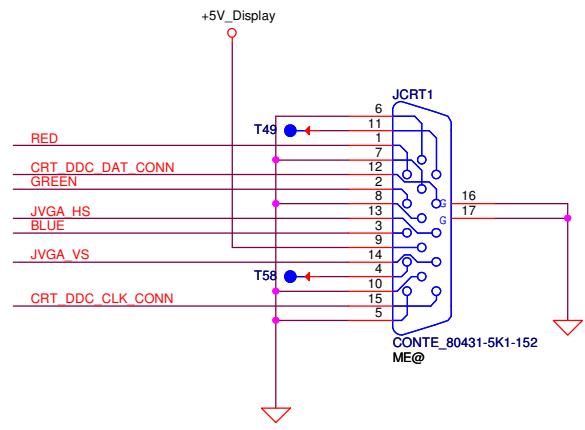
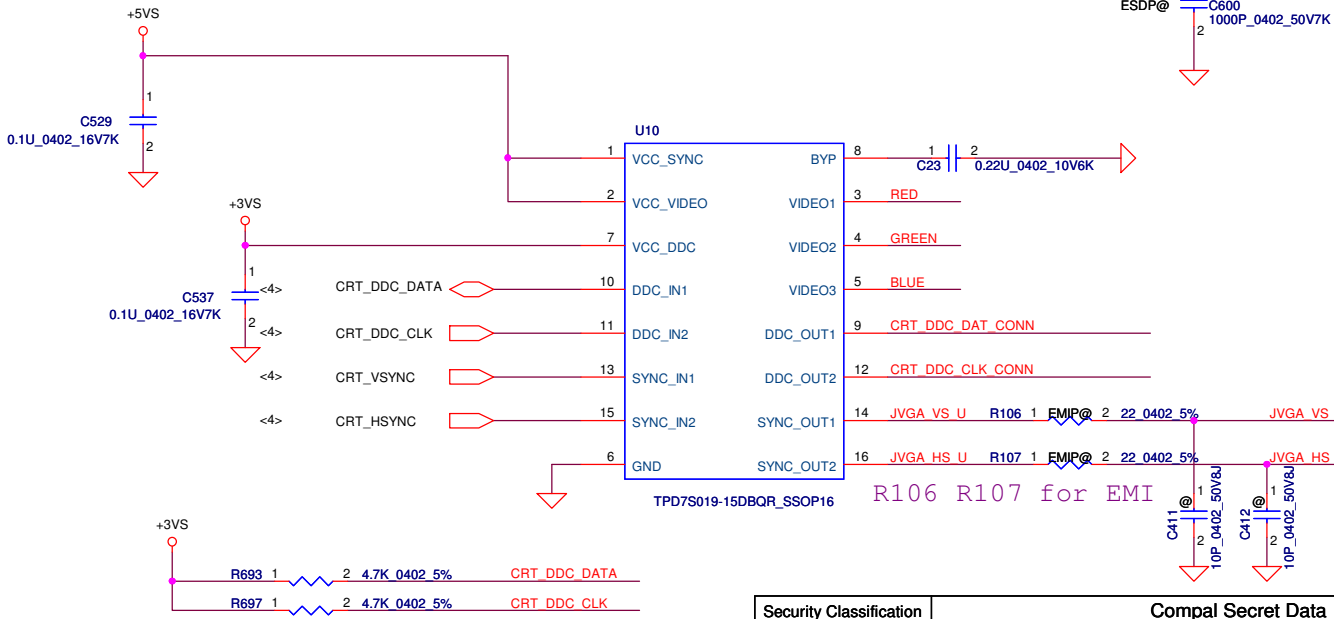
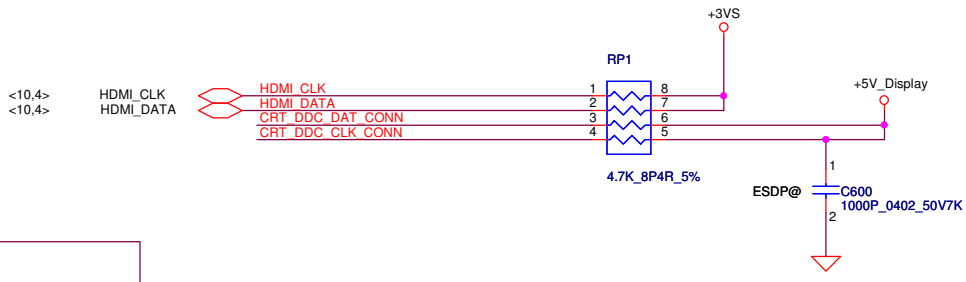
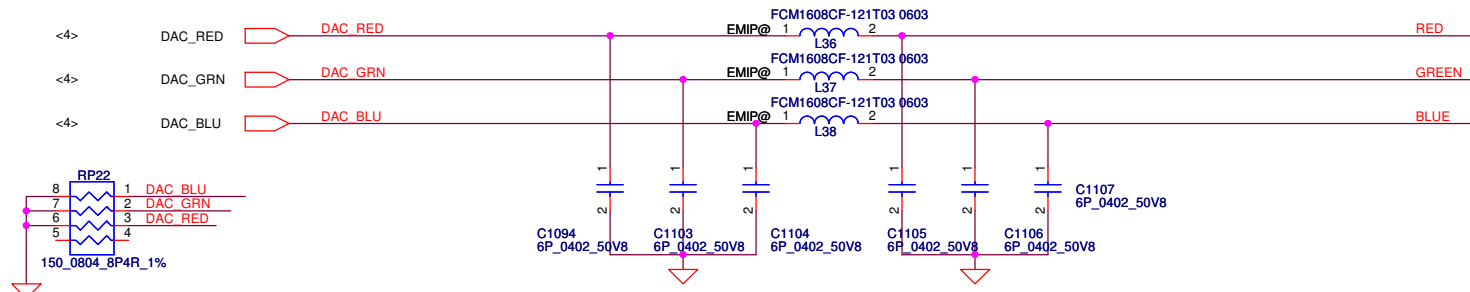

Security Classification	Compal Secret Data			Compal Electronics, Inc.		
Issued Date	2012/04/22	Deciphered Date	2015/04/22	Title CRT CONN		
THIS SHEET OF ENGINEERING DRAWING IS THE PROPRIETARY PROPERTY OF COMPAL ELECTRONICS, INC. AND CONTAINS CONFIDENTIAL AND TRADE SECRET INFORMATION. THIS SHEET MAY NOT BE TRANSFERRED FROM THE CUSTODY OF THE COMPETENT DIVISION OF R&D DEPARTMENT EXCEPT AS AUTHORIZED BY COMPAL ELECTRONICS, INC. NEITHER THIS SHEET NOR THE INFORMATION IT CONTAINS MAY BE USED BY OR DISCLOSED TO ANY THIRD PARTY WITHOUT PRIOR WRITTEN CONSENT OF COMPAL ELECTRONICS, INC.				Size B	Document Number VAWGA/GB	Rev 1.0
				Date:	Thursday, March 28, 2013	Sheet 12 of 37

### SATA HDD Conn.

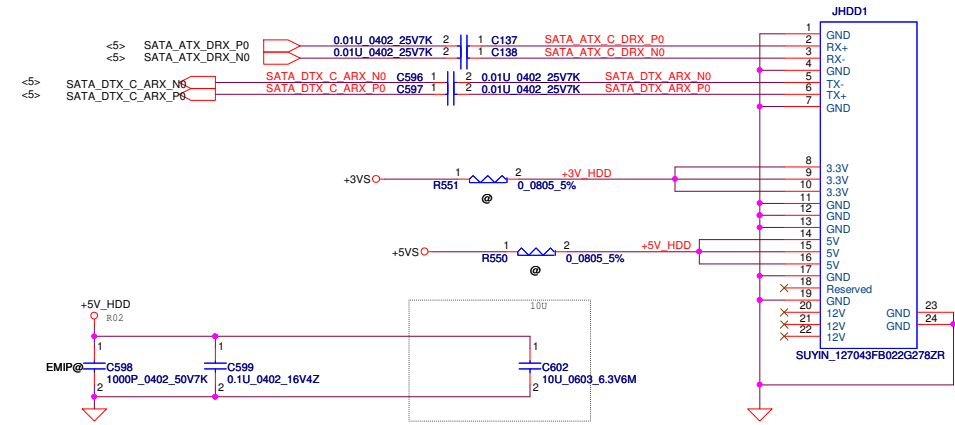

### FOR 15" SATA ODD FFC Conn.

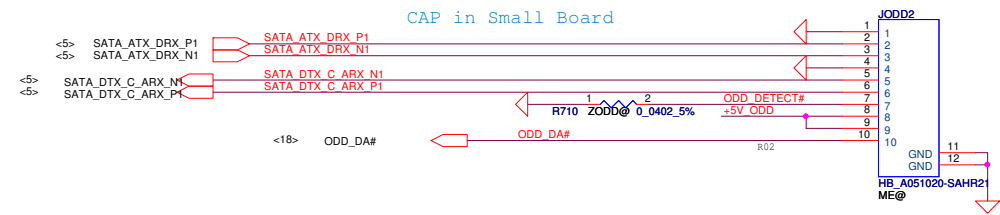

Co-layer

### ODD Power Control

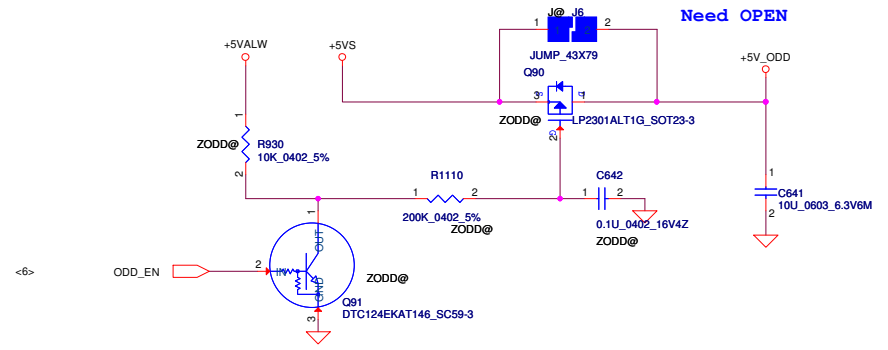

### FOR 14" SATA ODD Conn.

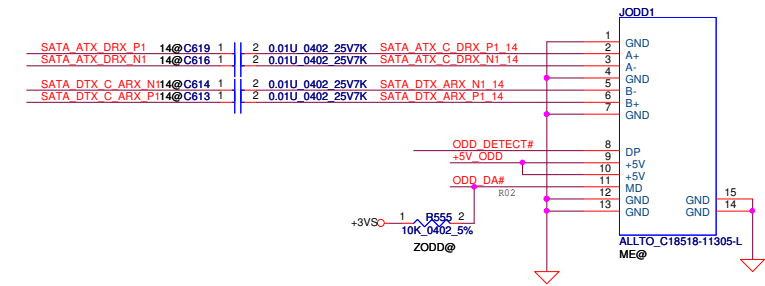

Security Classification	Compal Secret Data		Compal Electronics, Inc.	
Issued Date	2012/04/22	Deciphered Date	2015/04/22	Title
THIS SHEET OF ENGINEERING DRAWING IS THE PROPRIETARY PROPERTY OF COMPAL ELECTRONICS, INC. AND CONTAINS CONFIDENTIAL AND TRADE SECRET INFORMATION. THIS SHEET MAY NOT BE TRANSFERRED FROM THE CUSTODY OF THE COMPETENT DIVISION OF PRODUCT DEVELOPMENT EXCEPT AS AUTHORIZED BY COMPAL ELECTRONICS, INC. NEITHER THIS SHEET NOR THE INFORMATION IT CONTAINS MAY BE USED BY OR DISCLOSED TO ANY THIRD PARTY WITHOUT PRIOR WRITTEN CONSENT OF COMPAL ELECTRONICS, INC.				HDD/ODD/FAN/SCREW Document Number <b>VAWGA/GB</b> Date: Thursday, March 28, 2013   Sheet 13 of 37

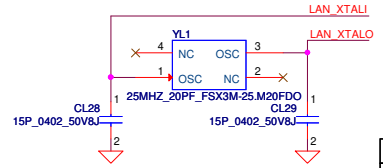
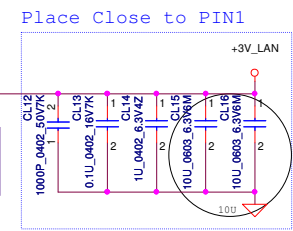
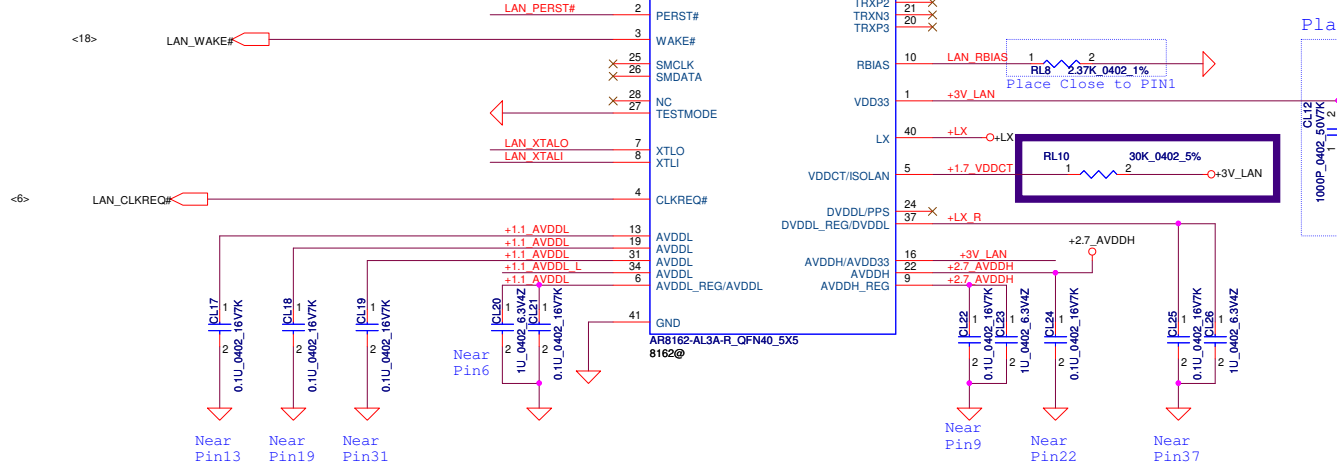
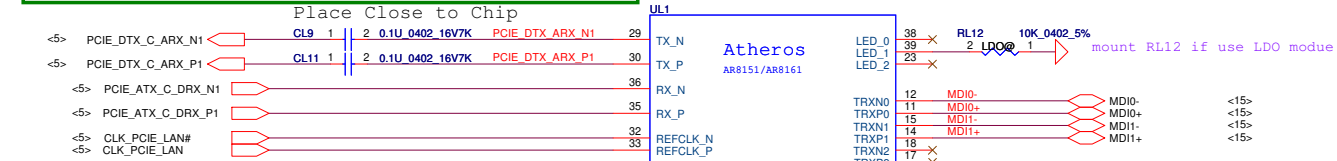
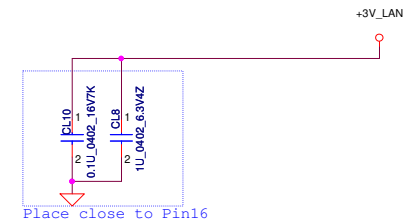
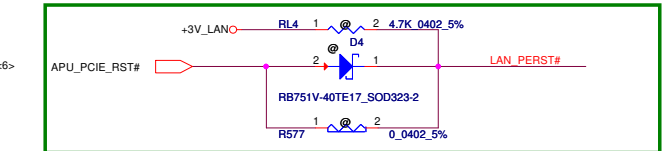
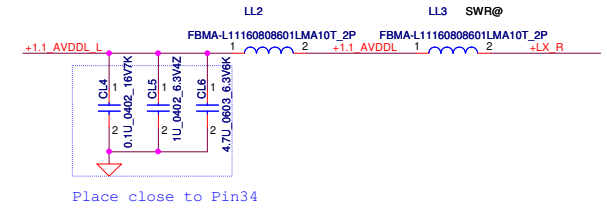
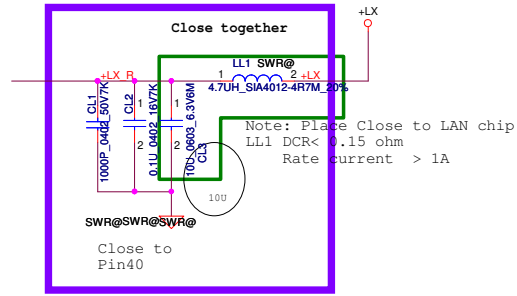
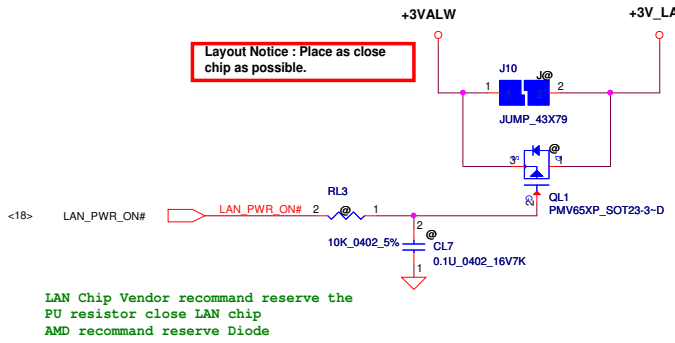

Security Classification	Compal Secret Data		Title	
Issued Date	2012/04/22	Deciphered Date	2015/04/22	LAN-AR8151
THIS SHEET OF ENGINEERING DRAWING IS THE PROPRIETARY PROPERTY OF COMPAL ELECTRONICS, INC. AND CONTAINS CONFIDENTIAL AND TRADE SECRET INFORMATION. THIS SHEET MAY NOT BE TRANSFERRED FROM THE CUSTODY OF THE COMPETENT DIVISION OF R&D DEPARTMENT EXCEPT AS AUTHORIZED BY COMPAL ELECTRONICS, INC. NEITHER THIS SHEET NOR THE INFORMATION IT CONTAINS MAY BE USED BY OR DISCLOSED TO ANY THIRD PARTY WITHOUT PRIOR WRITTEN CONSENT OF COMPAL ELECTRONICS, INC.				Rev 1.0
Date:	Thursday, March 28, 2013	Sheet	14	of 37

**DL1**  
 1'S PN:SC300001G00  
 2'S PN:SC300002E00

Place Close to TL1

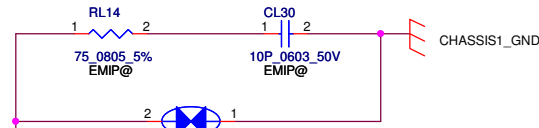
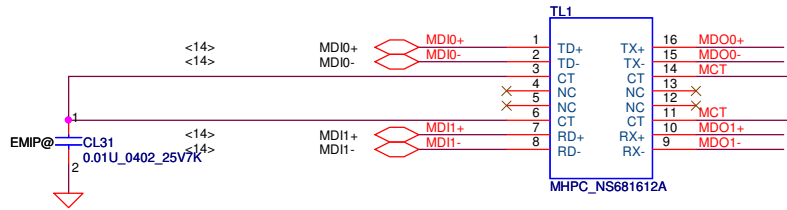
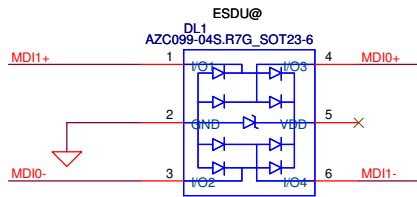

Place Close to TL1

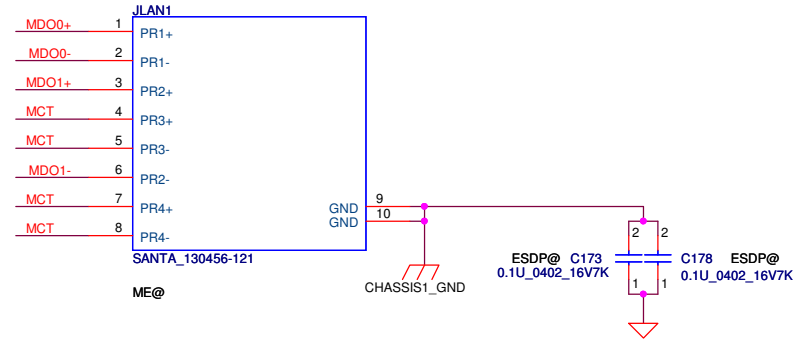
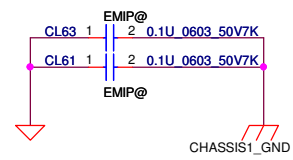

Security Classification	Compal Secret Data			Compal Electronics, Inc.	
Issued Date	2012/04/22	Deciphered Date	2015/04/22	Title	LAN_Transformer
THIS SHEET OF ENGINEERING DRAWING IS THE PROPRIETARY PROPERTY OF COMPAL ELECTRONICS, INC. AND CONTAINS CONFIDENTIAL AND TRADE SECRET INFORMATION. THIS SHEET MAY NOT BE TRANSFERRED FROM THE CUSTODY OF THE COMPETENT DIVISION OF R&D DEPARTMENT EXCEPT AS AUTHORIZED BY COMPAL ELECTRONICS, INC. NEITHER THIS SHEET NOR THE INFORMATION IT CONTAINS MAY BE USED BY OR DISCLOSED TO ANY THIRD PARTY WITHOUT PRIOR WRITTEN CONSENT OF COMPAL ELECTRONICS, INC.				Size	Document Number
				Rev	1.0
Date:	Thursday, March 28, 2013	Sheet	15	of	37

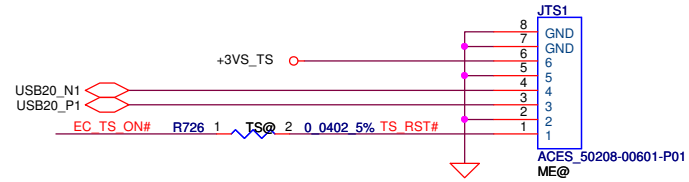
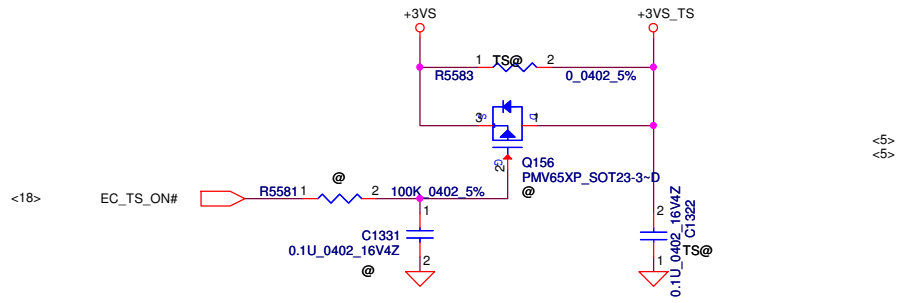

### Mini-Express Card(WLAN/WiMAX)

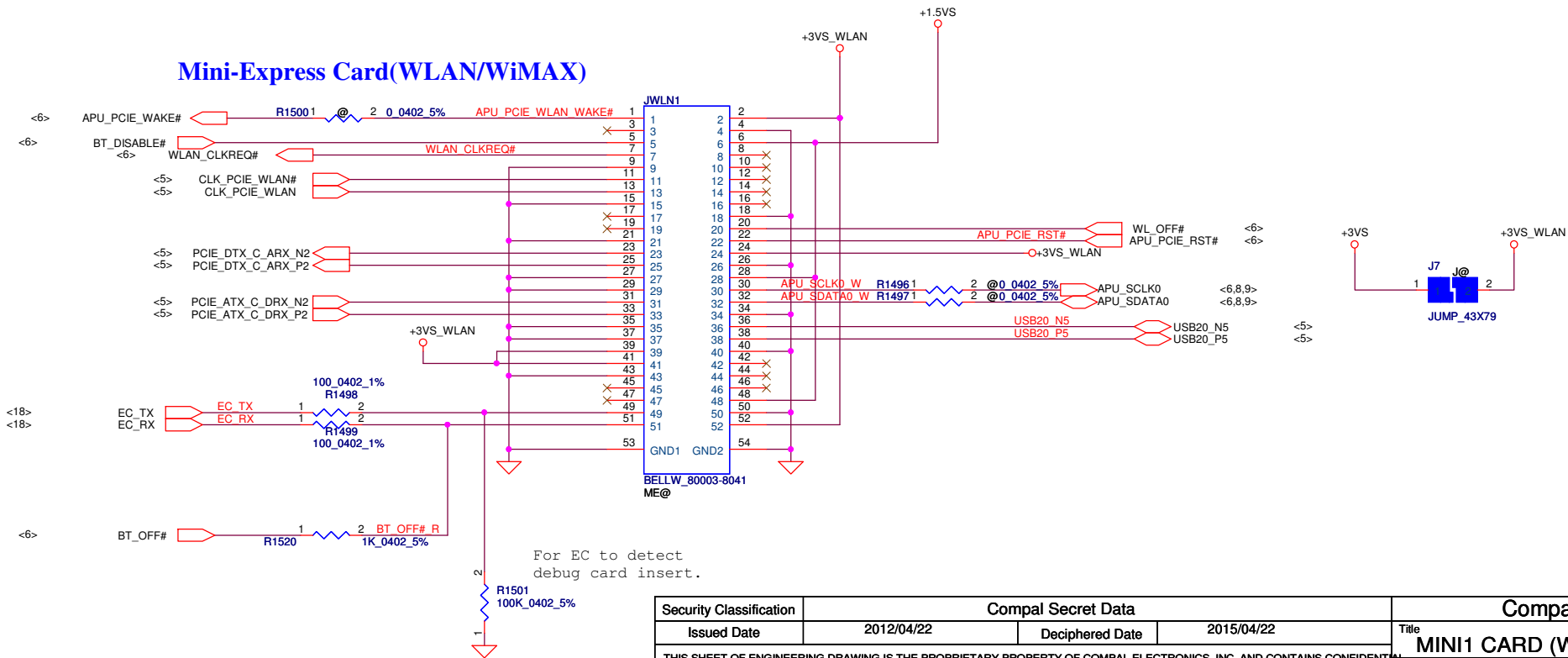

For EC to detect debug card insert.

Security Classification	Compal Secret Data		Compal Electronics, Inc.	
Issued Date	2012/04/22	Deciphered Date	2015/04/22	Title
THIS SHEET OF ENGINEERING DRAWING IS THE PROPRIETARY PROPERTY OF COMPAL ELECTRONICS, INC. AND CONTAINS CONFIDENTIAL AND TRADE SECRET INFORMATION. THIS SHEET MAY NOT BE TRANSFERRED FROM THE CUSTODY OF THE COMPETENT DIVISION OF R&D DEPARTMENT EXCEPT AS AUTHORIZED BY COMPAL ELECTRONICS, INC. NEITHER THIS SHEET NOR THE INFORMATION IT CONTAINS MAY BE USED BY OR DISCLOSED TO ANY THIRD PARTY WITHOUT PRIOR WRITTEN CONSENT OF COMPAL ELECTRONICS, INC.				MINI1 CARD (WLAN) / MINI2 CARD (Option)
Date: Thursday, March 28, 2013			Sheet 16 of 37	Rev 1.0



Vcc	3.3V +/- 5%				
R1562	100K +/- 5%				
Board ID	R1564	VAD_BID min	VAD_BID tYP	VAD_BID max	
0	0	0 V	0 V	0 V	MP
1	8.2K +/- 5%	0.216 V	0.250 V	0.289 V	PVT
2	18K +/- 5%	0.436 V	0.503 V	0.538 V	DVT
3	33K +/- 5%	0.712 V	0.819 V	0.875 V	EVT

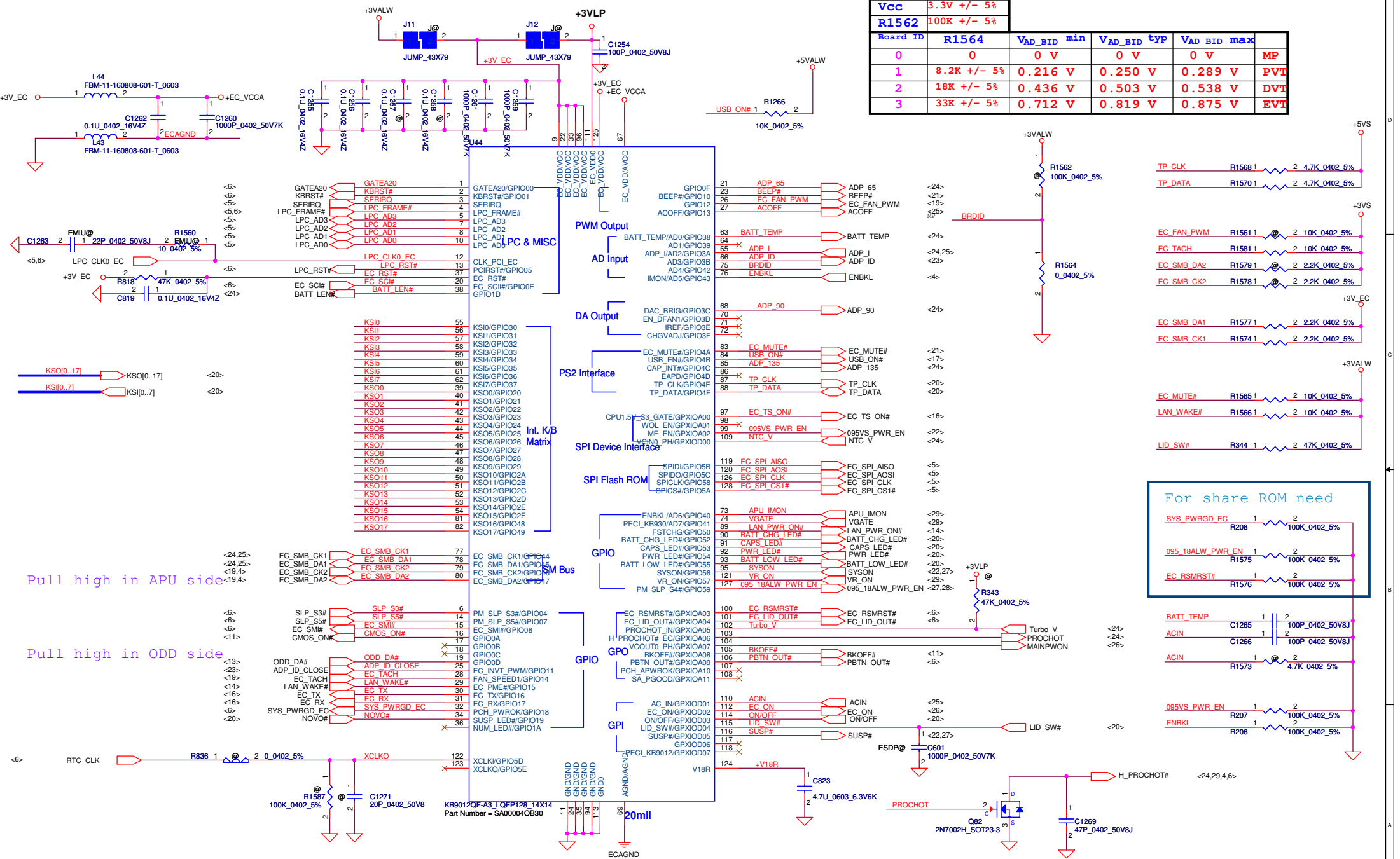

Security Classification		Compal Secret Data		Compal Electronics, Inc.	
Issued Date	2012/04/22	Deciphered Date	2015/04/22	Title	
THIS SHEET OF ENGINEERING DRAWING IS THE PROPRIETARY PROPERTY OF COMPAL ELECTRONICS, INC. AND CONTAINS CONFIDENTIAL AND TRADE SECRET INFORMATION. THIS SHEET MAY NOT BE TRANSFERRED FROM THE CUSTODY OF THE COMPETENT DIVISION OF THE DEPARTMENT EXCEPT AS AUTHORIZED BY COMPAL ELECTRONICS, INC. NEITHER THIS SHEET NOR THE INFORMATION IT CONTAINS MAY BE USED BY OR DISCLOSED TO ANY THIRD PARTY WITHOUT PRIOR WRITTEN CONSENT OF COMPAL ELECTRONICS, INC.				Document Number	Rev
				VAWGA/GB	1.0
Date: Thursday, March 28, 2013				Sheet	18 of 37

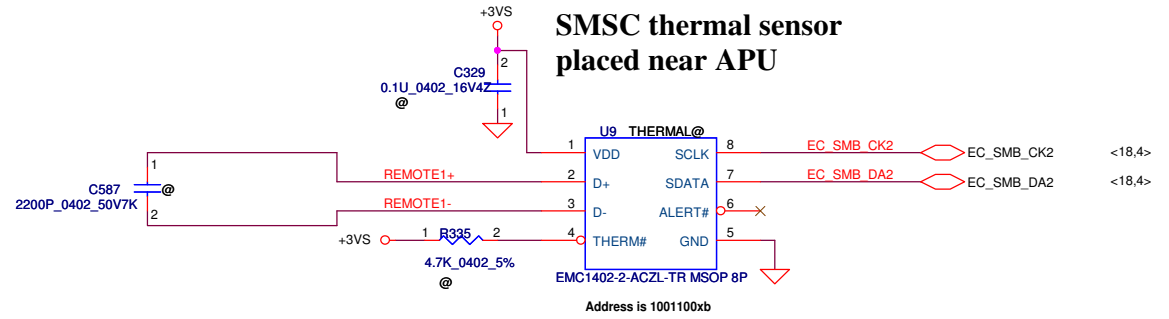

REMOTE1,2+/-:  
Trace width/space:10/10 mil  
Trace length:<8"

### FAN1 Conn

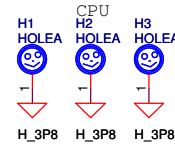
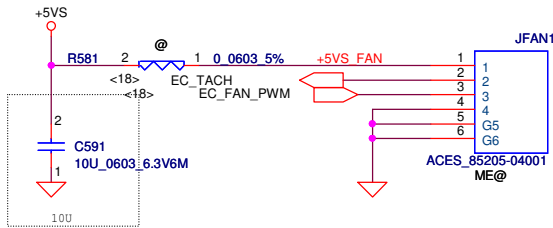

A



C

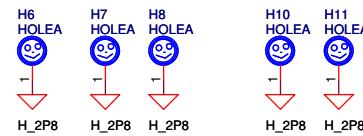
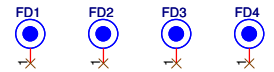

D

2P8 \* 9 pcd



E

M/B 橢圓孔



F

M/B 圓孔

Security Classification	Compal Secret Data			<b>Compal Electronics, Ltd.</b>	
Issued Date	2011/06/15	Deciphered Date	2012/07/11	Title	<b>Fintek-Thermal IC/FAN/screw</b>
THIS SHEET OF ENGINEERING DRAWING IS THE PROPRIETARY PROPERTY OF COMPAL ELECTRONICS, INC. AND CONTAINS CONFIDENTIAL AND TRADE SECRET INFORMATION. THIS SHEET MAY NOT BE TRANSFERRED FROM THE CUSTODY OF THE COMPETENT DIVISION OF R&D DEPARTMENT EXCEPT AS AUTHORIZED BY COMPAL ELECTRONICS, INC. NEITHER THIS SHEET NOR THE INFORMATION IT CONTAINS MAY BE USED BY OR DISCLOSED TO ANY THIRD PARTY WITHOUT PRIOR WRITTEN CONSENT OF COMPAL ELECTRONICS, INC.				Document Number	<b>VAWGA/GB</b>
				Date: Thursday, March 28, 2013	Sheet 19 of 37
				Rev	1.0

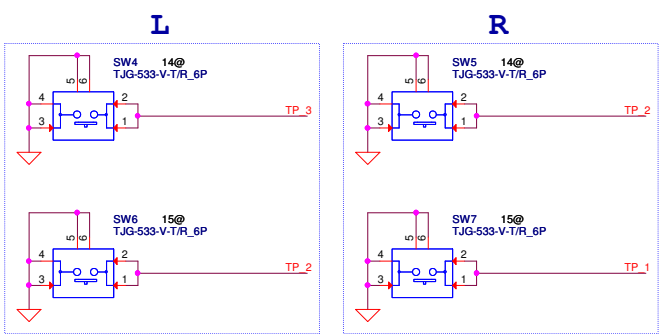
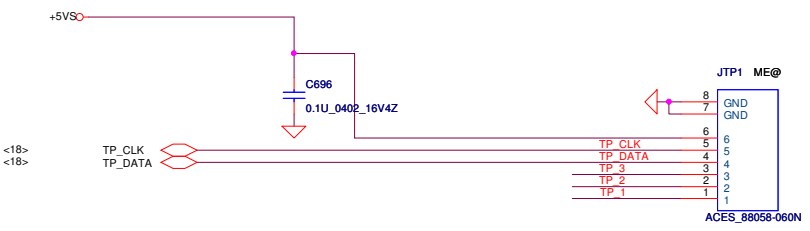
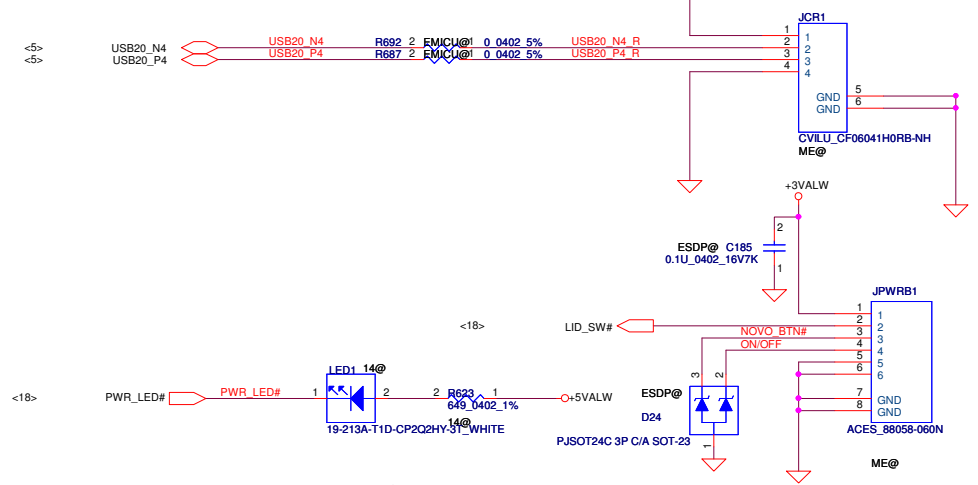
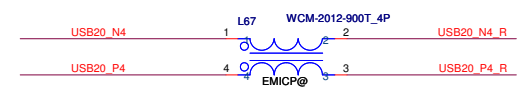
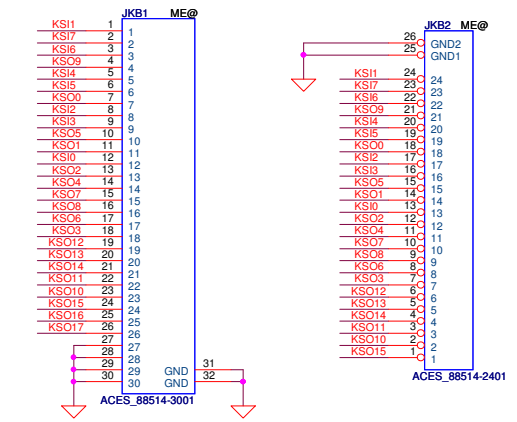
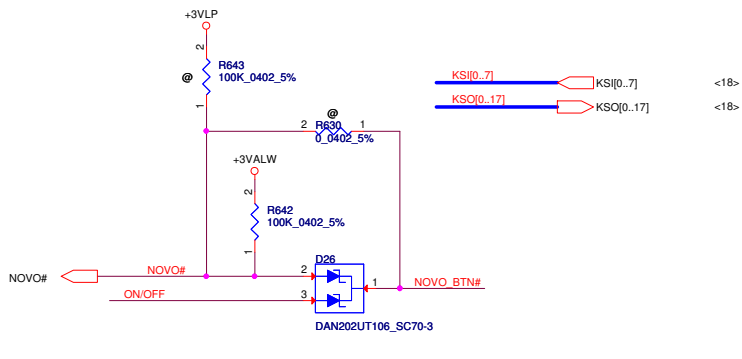
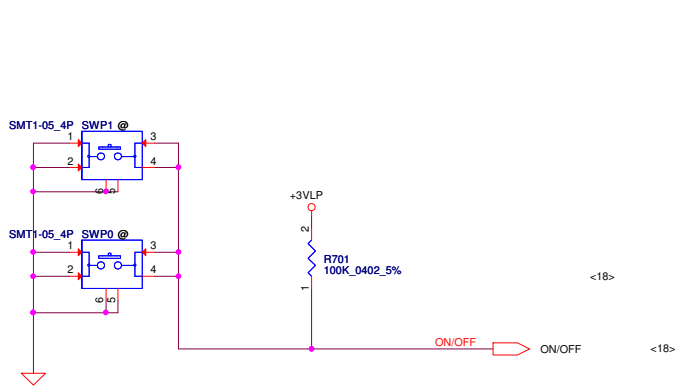

15/17"		14"	
1	VCC	1	VCC
2	CLK	2	CLK
3	DAT	3	DAT
4	GND	4	L
5	L	5	R
6	R	6	GND

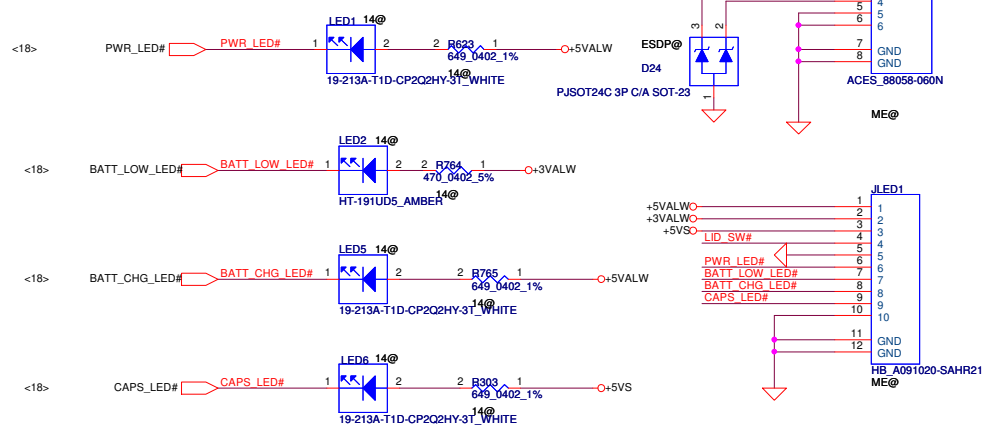

Security Classification	Compal Secret Data		Compal Electronics, Inc.	
Issued Date	2012/04/22	Deciphered Date	2015/04/22	Title
THIS SHEET OF ENGINEERING DRAWING IS THE PROPRIETARY PROPERTY OF COMPAL ELECTRONICS, INC. AND CONTAINS CONFIDENTIAL AND TRADE SECRET INFORMATION. THIS SHEET MAY NOT BE TRANSFERRED FROM THE CUSTODY OF THE COMPETENT DIVISION OF RESEARCH AND DEVELOPMENT DEPARTMENT EXCEPT AS AUTHORIZED BY COMPAL ELECTRONICS, INC. NEITHER THIS SHEET NOR THE INFORMATION IT CONTAINS MAY BE USED BY OR DISCLOSED TO ANY THIRD PARTY WITHOUT PRIOR WRITTEN CONSENT OF COMPAL ELECTRONICS, INC.				BIOS, I/O Port & K/B CONN/TP CONN/PBTN Document Number <b>VAWGA/GB</b> Date: Thursday, March 28, 2013
				Rev 1.0
				Sheet 20 of 37



**+5VALW TO +5VS**  
**+3VALW TO +3VS**  
**Load switch**

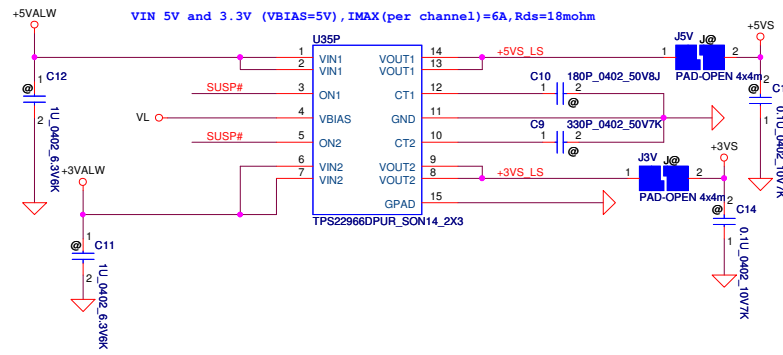

**+1.8VALW TO +1.8VS**  
**+0.95VALW TO +0.95VS**  
**Load switch**

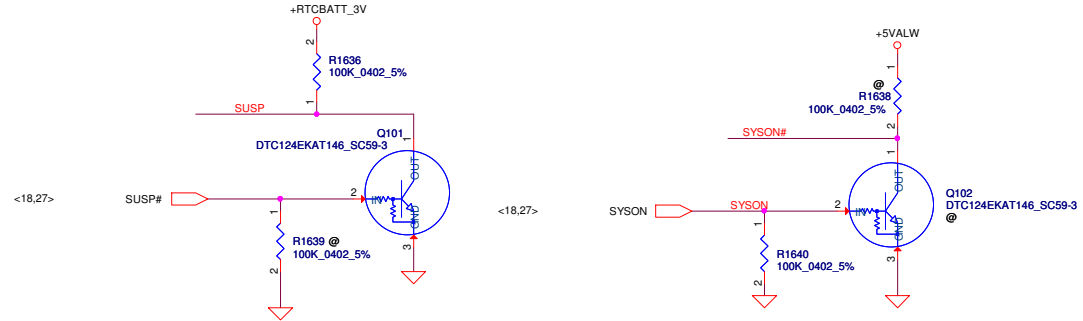
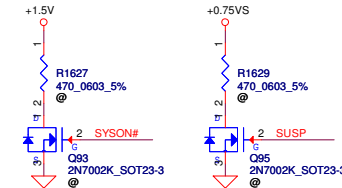
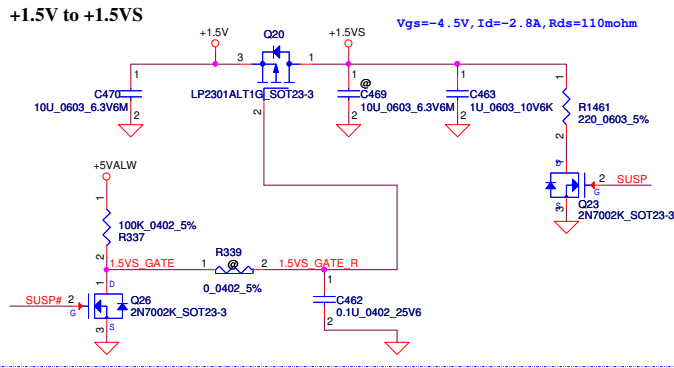
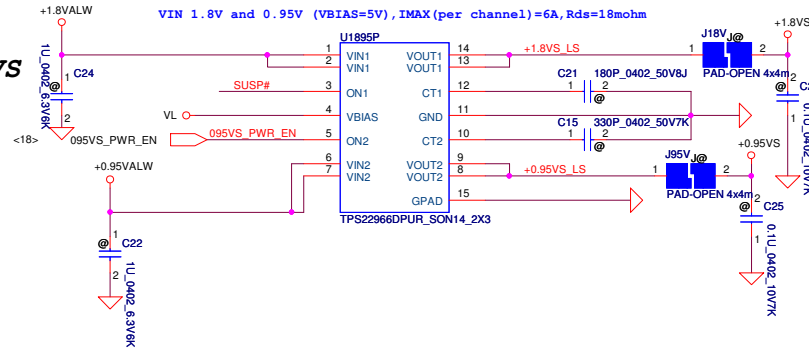

Security Classification	Compal Secret Data		Title	
Issued Date	2012/04/22	Deciphered Date	2015/04/22	DC Interface
THIS SHEET OF ENGINEERING DRAWING IS THE PROPRIETARY PROPERTY OF COMPAL ELECTRONICS, INC. AND CONTAINS CONFIDENTIAL AND TRADE SECRET INFORMATION. THIS SHEET MAY NOT BE TRANSFERRED FROM THE CUSTODY OF THE COMPETENT DIVISION OF R&D DEPARTMENT EXCEPT AS AUTHORIZED BY COMPAL ELECTRONICS, INC. NEITHER THIS SHEET NOR THE INFORMATION IT CONTAINS MAY BE USED BY OR DISCLOSED TO ANY THIRD PARTY WITHOUT PRIOR WRITTEN CONSENT OF COMPAL ELECTRONICS, INC.				Document Number <b>VAWGA/GB</b> Date: Thursday, March 28, 2013
				Rev 1.0 Sheet 22 of 37

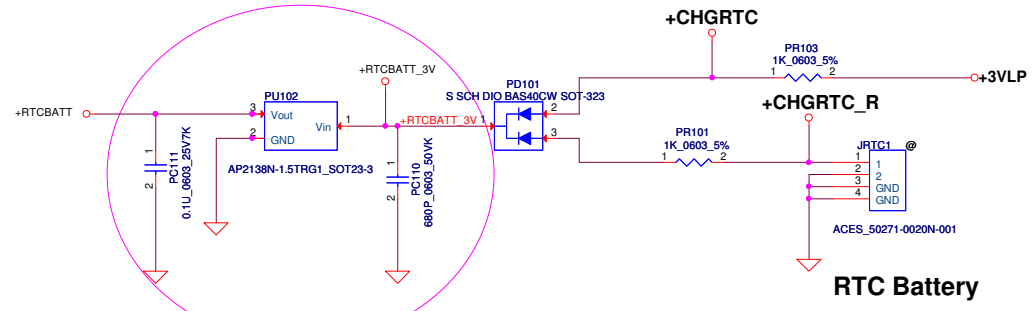
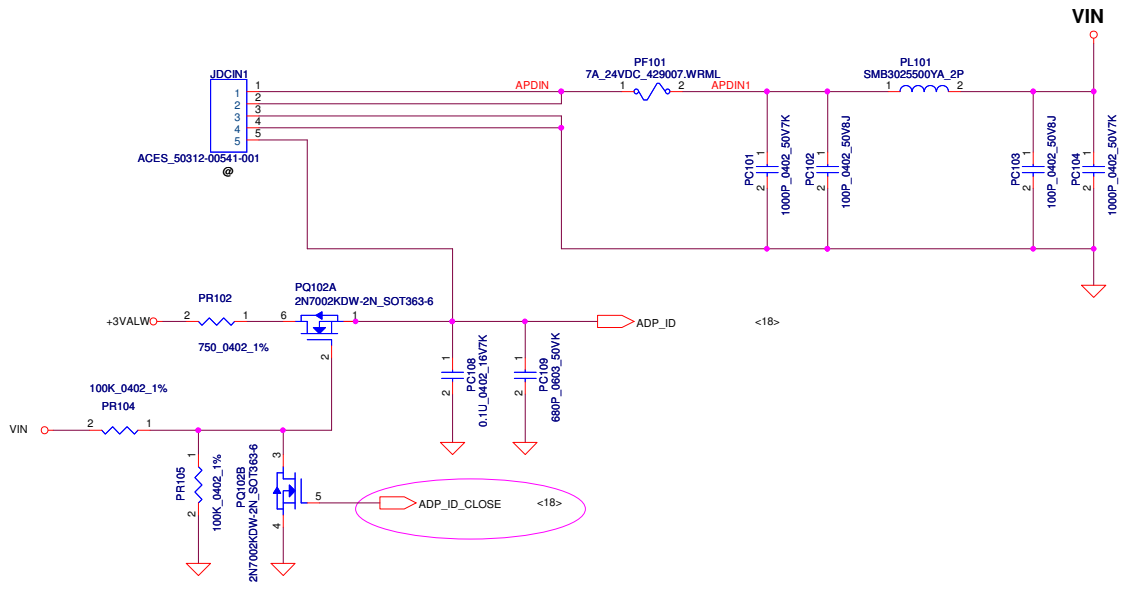

Need use +3.3V transfer to +1.5V LDO to APU side for Kaibini

Security Classification	Compal Secret Data		Title	
Issued Date	2011/06/15	Deciphered Date	2012/07/11	Compal Electronics, Inc.
THIS SHEET OF ENGINEERING DRAWING IS THE PROPRIETARY PROPERTY OF COMPAL ELECTRONICS, INC. AND CONTAINS CONFIDENTIAL AND TRADE SECRET INFORMATION. THIS SHEET MAY NOT BE TRANSFERRED FROM THE CUSTODY OF THE COMPETENT DIVISION OF FIELD CUSTOMER DEPARTMENT EXCEPT AS AUTHORIZED BY COMPAL ELECTRONICS, INC. NEITHER THIS SHEET NOR THE INFORMATION IT CONTAINS MAY BE USED BY OR DISCLOSED TO ANY THIRD PARTY WITHOUT PRIOR WRITTEN CONSENT OF COMPAL ELECTRONICS, INC.				Document Number
				VAWG/B
				Rev 1.0
Date: Thursday, March 28, 2013				Sheet 23 of 37





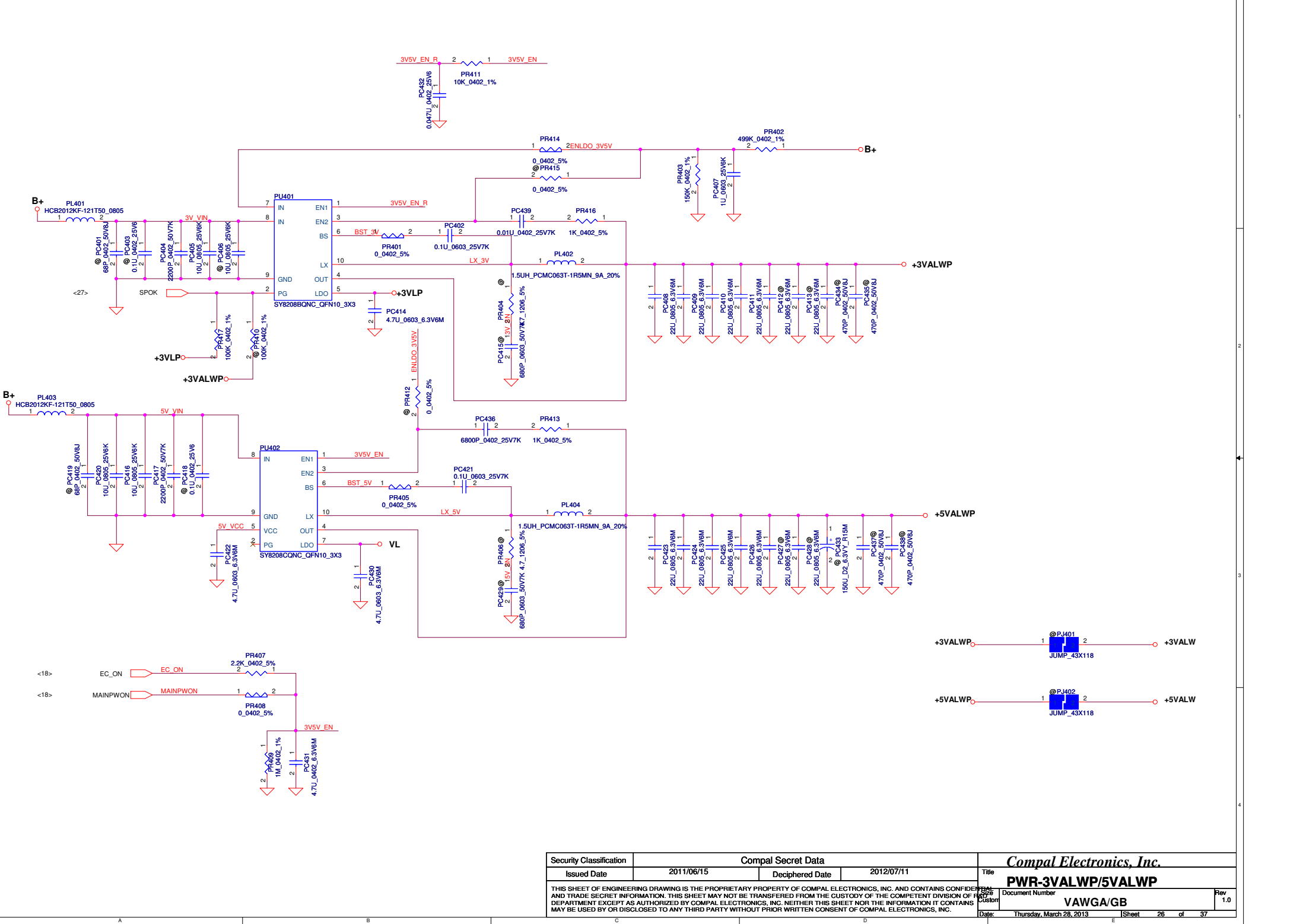

Security Classification	Compal Secret Data	
Issued Date	2011/06/15	Deciphered Date
		2012/07/11
THIS SHEET OF ENGINEERING DRAWING IS THE PROPRIETARY PROPERTY OF COMPAL ELECTRONICS, INC. AND CONTAINS CONFIDENTIAL AND TRADE SECRET INFORMATION. THIS SHEET MAY NOT BE TRANSFERRED FROM THE CUSTODY OF THE COMPETENT DIVISION OF PRODUCT DEVELOPMENT EXCEPT AS AUTHORIZED BY COMPAL ELECTRONICS, INC. NEITHER THIS SHEET NOR THE INFORMATION IT CONTAINS MAY BE USED BY OR DISCLOSED TO ANY THIRD PARTY WITHOUT PRIOR WRITTEN CONSENT OF COMPAL ELECTRONICS, INC.		

<b>Compal Electronics, Inc.</b>	
Title	<b>PWR-3VALWP/5VALWP</b>
Document Number	<b>VAWGA/GB</b>
Date: Thursday, March 28, 2013	Rev 1.0
Sheet 26	of 37



095\_18ALW\_PWR\_EN

<18>

<27>

SPOK

PR605 reserve

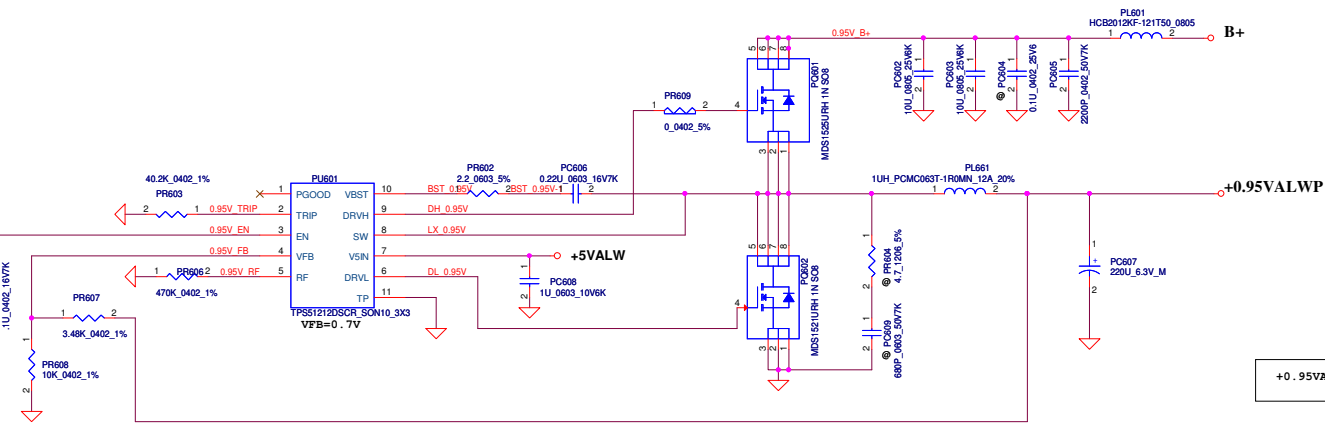
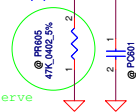

+0.95VALWP OCP (min)=15.6A

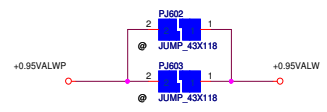

Security Classification	Compal Secret Data		Compal Electronics, Inc.	
Issued Date	2011/06/15	Deciphered Date	2012/07/11	Title
THIS SHEET OF ENGINEERING DRAWING IS THE PROPRIETARY PROPERTY OF COMPAL ELECTRONICS, INC. AND CONTAINS CONFIDENTIAL AND TRADE SECRET INFORMATION. THIS SHEET MAY NOT BE TRANSFERRED FROM THE CUSTODY OF THE COMPETENT DIVISION OF R&D DEPARTMENT EXCEPT AS AUTHORIZED BY COMPAL ELECTRONICS, INC. NEITHER THIS SHEET NOR THE INFORMATION IT CONTAINS MAY BE USED BY OR DISCLOSED TO ANY THIRD PARTY WITHOUT PRIOR WRITTEN CONSENT OF COMPAL ELECTRONICS, INC.				<b>PWR-+0.95VALWP</b> Document Number <b>VAWGA/B</b> Date: Thursday, March 28, 2013   Sheet 28 of 37
Rev	1.0			



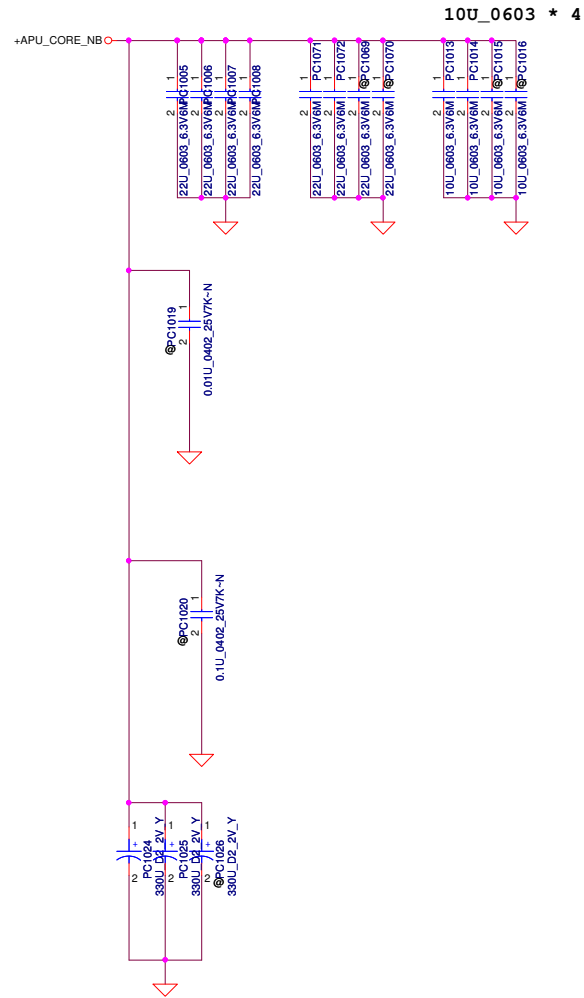
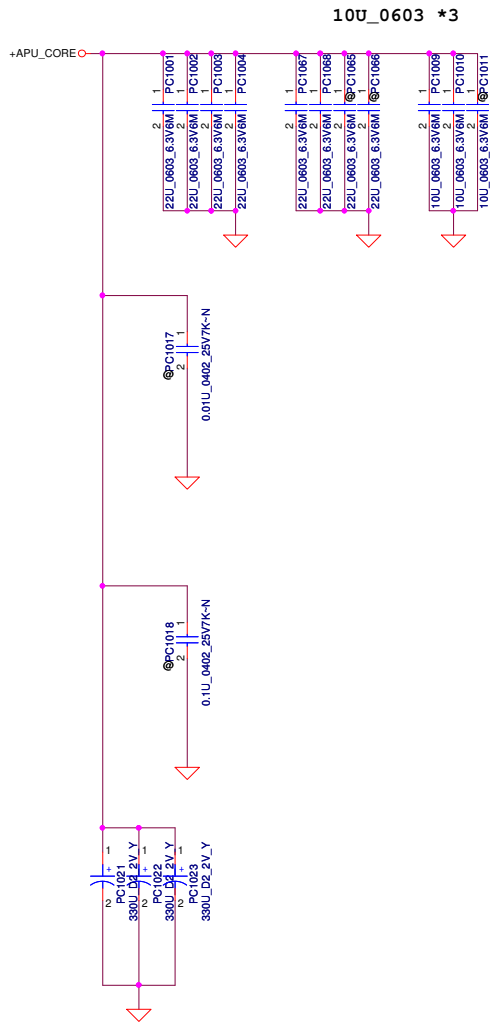

Security Classification	Compal Secret Data		
Issued Date	2011/07/08	Deciphered Date	2015/07/08
THIS SHEET OF ENGINEERING DRAWING IS THE PROPRIETARY PROPERTY OF COMPAL ELECTRONICS, INC. AND CONTAINS CONFIDENTIAL AND TRADE SECRET INFORMATION. THIS SHEET MAY NOT BE TRANSFERRED FROM THE CUSTODY OF THE COMPETENT DIVISION OF PRODUCT DEVELOPMENT EXCEPT AS AUTHORIZED BY COMPAL ELECTRONICS, INC. NEITHER THIS SHEET NOR THE INFORMATION IT CONTAINS MAY BE USED BY OR DISCLOSED TO ANY THIRD PARTY WITHOUT PRIOR WRITTEN CONSENT OF COMPAL ELECTRONICS, INC.			

Compal Electronics, Inc.		
Title	PWR-PROCESSOR DECOUPLING	
Document Number	VAWGA/B	
Date	Thursday, March 28, 2013	Rev 1.0
Sheet	30	of 37

Item	Reason for change	PG#	Modify List	Date	Phase
1					
2					
3					
4					
5					
6					
7					
8					
9					
10					
11					
12					
13					
14					
15					
16					
17					

Security Classification		Compal Secret Data		Compal Electronics, Inc.	
Issued Date	2011/06/15	Deciphered Date	2012/07/11	Title	
THIS SHEET OF ENGINEERING DRAWING IS THE PROPRIETARY PROPERTY OF COMPAL ELECTRONICS, INC. AND CONTAINS CONFIDENTIAL AND TRADE SECRET INFORMATION. THIS SHEET MAY NOT BE TRANSFERRED FROM THE CUSTODY OF THE COMPETENT DIVISION OF R&D DEPARTMENT EXCEPT AS AUTHORIZED BY COMPAL ELECTRONICS, INC. NEITHER THIS SHEET NOR THE INFORMATION IT CONTAINS MAY BE USED BY OR DISCLOSED TO ANY THIRD PARTY WITHOUT PRIOR WRITTEN CONSENT OF COMPAL ELECTRONICS, INC.				PIR (PWR)	
Size		Document Number		Rev	
Custom		C38-G series Chief River Schematic		1.0	
Date: Thursday, March 28, 2013				Sheet 31 of 37	

Item	Reason for change	PG#	Modify List	Date	Phase
1					
2					
3					
4					
5					
6					
7					
8					
9					
10					
11					
12					
13					
14					
15					
16					
17					

Security Classification		Compal Secret Data		Compal Electronics, Inc.	
Issued Date	2011/06/15	Deciphered Date	2012/07/11	Title	
THIS SHEET OF ENGINEERING DRAWING IS THE PROPRIETARY PROPERTY OF COMPAL ELECTRONICS, INC. AND CONTAINS CONFIDENTIAL AND TRADE SECRET INFORMATION. THIS SHEET MAY NOT BE TRANSFERRED FROM THE CUSTODY OF THE COMPETENT DIVISION OF R&D DEPARTMENT EXCEPT AS AUTHORIZED BY COMPAL ELECTRONICS, INC. NEITHER THIS SHEET NOR THE INFORMATION IT CONTAINS MAY BE USED BY OR DISCLOSED TO ANY THIRD PARTY WITHOUT PRIOR WRITTEN CONSENT OF COMPAL ELECTRONICS, INC.				Size	Document Number
				Custom	C38-G series Chief River Schematic <sup>1.0</sup>
				Date:	Thursday, March 28, 2013
				Sheet	32 of 37

Version change list (P.I.R. List)

Item	Reason for change	PG#	Modify List	Date	Phase
1	For share rom	18	Change SYS_PWRGD_EC from pin 86 to pin 32	12/17	DVT
2	For 095VS_PWR_EN pull down	18	Add R207	12/17	DVT
3	For VBIAS first raise up	22	Change U1895V, U35P, U1895P VBIAS from +5VALW to VL	12/17	DVT
4	For follow VIWGP design	17	Change JUSB3 pin define	12/18	DVT
5	For Audio Precision	21	Change CA36, CA46 from 1U to 2.2U	12/21	DVT
6	For SYS_PWRGD_EC pull down	18	Add R208	12/24	DVT
7	For share rom	18	Change R1575, R1576 to 100K	12/24	DVT
8	For reserve EC +3VL	18 05	Add J11, J12 and modify +3VALW to +3V_EC	12/24	DVT
9	For share ROM	05	modify ROM net-name & resistor value	12/24	DVT
10	For common VIWGP design	12	modify R106, R107 to 22ohm	12/24	DVT
11	For power S3 reduction	18	Change EC_INVT_PWM to ADP_ID_CLOSE	12/25	DVT
12	For common VIWGP design	13	Change JODD1 symbol	12/27	DVT
13	For reserve wake on wlan function	16	Add R1500	12/27	DVT
14	For 1.5VS discharge	22	Change R339 to 0ohm, mount Q23 & R1461	12/29	DVT
15	For AMD suggest	4	Change R576 to 0ohm	12/29	DVT
16	For +3VALW APU Power Consumption	7	Add R582	01/03	DVT
17	For ESD request	12 18 29	Add C600, C601, PC6601, PC6602	01/03	DVT
18	For no support DC wake & LID function	18	Pull high only SMB & RST use +3V_EC, other use +3VALW	01/04	DVT
19	For reserve cost down experiment	20	Add R630, R643	01/04	DVT
20	For Common VIWGP	20	Change SW4, SW5, SW6, SW7 footprint	01/04	DVT
21	For instant plug/unplug AC has beep sound	21	@RA22	01/04	DVT
22	For Crystal Capactance fine tune	5 6	Modify C794, C795, C682, C686 value	01/09	DVT

Security Classification		Compal Secret Data		Compal Electronics, Inc.	
Issued Date	2011/06/15	Deciphered Date	2012/07/11	Title	
THIS SHEET OF ENGINEERING DRAWING IS THE PROPRIETARY PROPERTY OF COMPAL ELECTRONICS, INC. AND CONTAINS CONFIDENTIAL AND TRADE SECRET INFORMATION. THIS SHEET MAY NOT BE TRANSFERRED FROM THE CUSTODY OF THE COMPETENT DIVISION OF R&D DEPARTMENT EXCEPT AS AUTHORIZED BY COMPAL ELECTRONICS, INC. NEITHER THIS SHEET NOR THE INFORMATION IT CONTAINS MAY BE USED BY OR DISCLOSED TO ANY THIRD PARTY WITHOUT PRIOR WRITTEN CONSENT OF COMPAL ELECTRONICS, INC.				Size	Rev
				Custom	0
				C38-G series Chief River Schematic	
				Date:	Thursday, March 28, 2013
				Sheet	33 of 37

Version change list (P.I.R. List)

Item	Reason for change	PG#	Modify List	Date	Phase
1	For EMI request	20	Change L67 to EMICP@, Change R692,R687 to EMICU@	02/02	PVT
2	For Share ROM recoverable solution as original method	05	Add RP12	02/02	PVT
3	For ZiZi noise	21	Change AVDD_HP from +3VS to +3VLP	02/02	PVT
4	For follow KABINI latest CRB	04	@ R576,C164,C342	02/02	PVT
5	For APU control PWM only	11	Delete R1465	02/02	PVT
6	For Corret Net-name to prevet confuse	04 11	Change TL_INV_T_PWM, TL_ENVDD to APU_INV_T_PWM, APU_ENVDD	02/02	PVT
7	For Reserve DDC CLK DATA pull high	12	Add R693, R697	02/02	PVT
8	For Common Intel project	20	Change R623,R765,R303 to 620ohm	02/02	PVT
9	For Common Intel project	13	Reserve R551	02/02	PVT
10	For reduce BOM	21	Delete RA3, and Change RA4 to short-pad	02/05	PVT
11	For reduce BOM	16	Change R1498,R1499 from 0 ohm to 100 ohm	02/05	PVT
12	For reduce BOM	11	Change R1463 from 0 ohm to short-pad	02/06	PVT
13	For better audio precision performance	21	Change CA27,CA28 from 1U to 2.2U	02/08	PVT
14	For reduce BOM & layout concern	07	Delete C195	02/16	PVT
15	For test point request	12	Add T49, T58 on JCRT1	02/18	PVT
16	For ESD request	15	Add C173, C178	02/18	PVT
17	For reduce BOM	05	Change R116, R119, R125, R126 to short-pad	02/18	PVT
18	For Crystal timing	06	Change C682 from 18P to 22P	02/20	PVT
19	For ESD request	20	Change D24 from ESDU@ to ESDP@, Part number from SCA00000E00 to SCA00001G00	02/23	PVT
20	For EMI request	11 17 20	Change L58,L51,L55,L66,L67 from SM070000K00 to SM070000Z00	02/23	PVT
21					
22					
23					

Security Classification		Compal Secret Data		Compal Electronics, Inc.	
Issued Date	2011/06/15	Deciphered Date	2012/07/11	Title	
THIS SHEET OF ENGINEERING DRAWING IS THE PROPRIETARY PROPERTY OF COMPAL ELECTRONICS, INC. AND CONTAINS CONFIDENTIAL AND TRADE SECRET INFORMATION. THIS SHEET MAY NOT BE TRANSFERRED FROM THE CUSTODY OF THE COMPETENT DIVISION OF R&D DEPARTMENT EXCEPT AS AUTHORIZED BY COMPAL ELECTRONICS, INC. NEITHER THIS SHEET NOR THE INFORMATION IT CONTAINS MAY BE USED BY OR DISCLOSED TO ANY THIRD PARTY WITHOUT PRIOR WRITTEN CONSENT OF COMPAL ELECTRONICS, INC.				Size	Document Number
				Custom	C38-G series Chief River Schematic <sup>1.0</sup>
				Date:	Thursday, March 28, 2013
				Sheet	34 of 37

**Version change list (P.I.R. List)**

Item	Reason for change	PG#	Modify List	Date	Phase
1	For Common Intel project	20	Change R623,R765,R303 to 649ohm	03/05	PreMP
2	For Reduce BOM	05	Change R103, R104 to short-pad	03/11	PreMP
3	For Reduce BOM	11	Change R696, R695, R813 to short-pad	03/11	PreMP
4	For Reduce BOM	13	Change R550 to short-pad	03/11	PreMP
5	For Reduce BOM	18	Change R1564 to short-pad	03/11	PreMP
6	For Reduce BOM	19	Change R581 to short-pad	03/11	PreMP
7	For Reduce BOM	21	Change RA11 to short-pad	03/11	PreMP
8	For Reduce BOM	22	Change R339 to short-pad	03/11	PreMP
9	For Reduce BOM	07	Change R582 to short-pad	03/11	PreMP
10	For ESD require	20	Add C185	03/25	PreMP
11	For Module Design	12	Change R693, R697 from 10k to 4.7k	03/25	PreMP
12	For ESD require	04	Add C195	03/26	PreMP
13	For Reduce BOM	04	@ RP11	03/26	PreMP
14	For Board ID	18	@ R1562 and change R1564 to 0ohm	03/28	PreMP
15					
16					
17					

Security Classification		Compal Secret Data		Compal Electronics, Inc.	
Issued Date	2011/06/15	Deciphered Date	2012/07/11	Title	
THIS SHEET OF ENGINEERING DRAWING IS THE PROPRIETARY PROPERTY OF COMPAL ELECTRONICS, INC. AND CONTAINS CONFIDENTIAL AND TRADE SECRET INFORMATION. THIS SHEET MAY NOT BE TRANSFERRED FROM THE CUSTODY OF THE COMPETENT DIVISION OF R&D DEPARTMENT EXCEPT AS AUTHORIZED BY COMPAL ELECTRONICS, INC. NEITHER THIS SHEET NOR THE INFORMATION IT CONTAINS MAY BE USED BY OR DISCLOSED TO ANY THIRD PARTY WITHOUT PRIOR WRITTEN CONSENT OF COMPAL ELECTRONICS, INC.				PIR (PWR)	
Size	Custom	Document Number	C38-G series Chief River Schematic		Rev 1.0
Date:	Thursday, March 28, 2013	Sheet	35	of	37

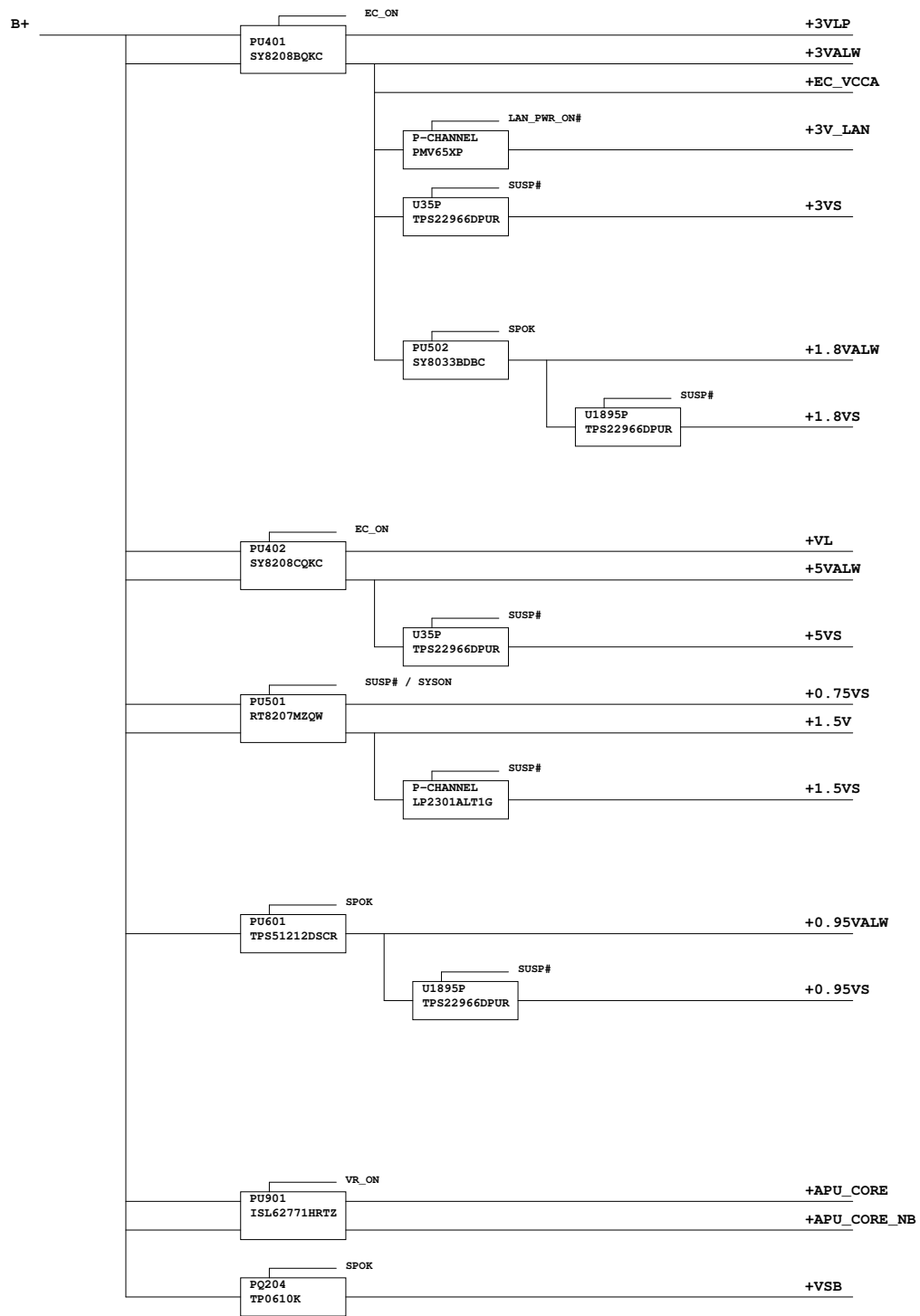

Security Classification	Compal Secret Data		Title	
Issued Date	Deciphered Date	Date		Rev
THIS SHEET OF ENGINEERING DRAWING IS THE PROPRIETARY PROPERTY OF COMPAL ELECTRONICS, INC. AND CONTAINS CONFIDENTIAL AND TRADE SECRET INFORMATION. THIS SHEET MAY NOT BE TRANSFERRED FROM THE CUSTODY OF THE COMPETENT DIVISION OF RESEARCH AND DEVELOPMENT EXCEPT AS AUTHORIZED BY COMPAL ELECTRONICS, INC. NEITHER THIS SHEET NOR THE INFORMATION IT CONTAINS MAY BE USED BY OR DISCLOSED TO ANY THIRD PARTY WITHOUT PRIOR WRITTEN CONSENT OF COMPAL ELECTRONICS, INC.			Document Number	1.0
			YAWGA/GB	
			Thursday, March 28, 2013	Sheet 36 of 37

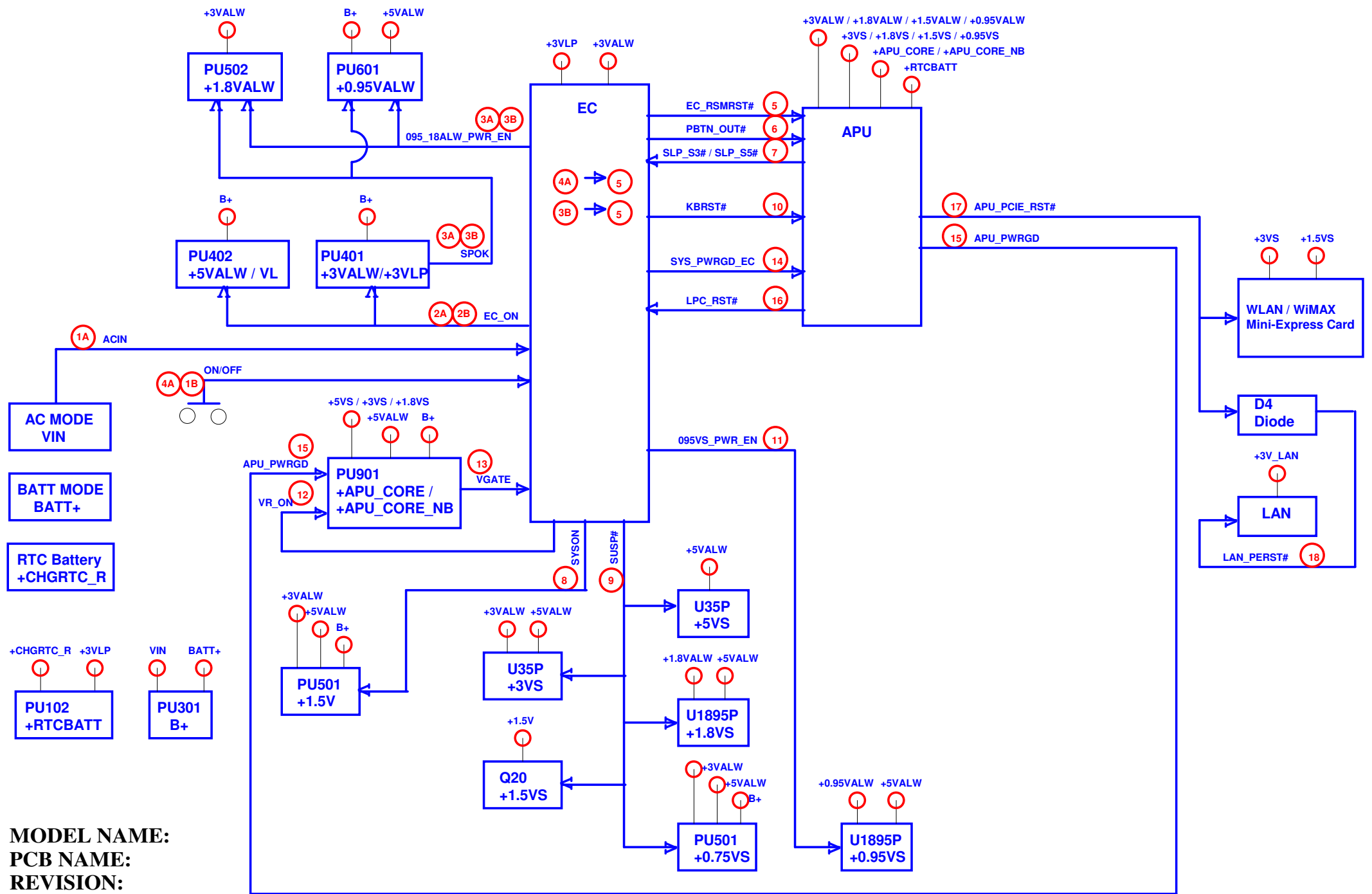

MODEL NAME:  
 PCB NAME:  
 REVISION:  
 DATE: 2011/11/23

**COMPAL CONFIDENTIAL**

Security Classification	Compal Secret Data		Title	
Issued Date		Deciphered Date		Compal Electronics, Inc.
THIS SHEET OF ENGINEERING DRAWING IS THE PROPRIETARY PROPERTY OF COMPAL ELECTRONICS, INC. AND CONTAINS CONFIDENTIAL AND TRADE SECRET INFORMATION. THIS SHEET MAY NOT BE TRANSFERRED FROM THE CUSTODY OF THE COMPETENT DIVISION OF FIELD CUSTOMER DEPARTMENT EXCEPT AS AUTHORIZED BY COMPAL ELECTRONICS, INC. NEITHER THIS SHEET NOR THE INFORMATION IT CONTAINS MAY BE USED BY OR DISCLOSED TO ANY THIRD PARTY WITHOUT PRIOR WRITTEN CONSENT OF COMPAL ELECTRONICS, INC.				Power sequence
Doc No	Doc Number	Rev	1.0	Sheet of