

1 2 3 4 5 6 7 8

A

A

B

B

C

C

D

D

E

E

F

F

Manaus10AB\ABG

X01 Build

2010.08.02

INVENTEC			
TITLE <i>Berlin 10AD</i>			
SIZE A3	CODE CS	DOC. NUMBER <i>1310A2333201</i>	REV X01
CHANGE by <i>Devin Hsieh</i>		2-Aug-2010	
SHEET		1	OF 48

1 2 3 4 5 6 7 8

TABLE OF CONTENTS

PAGE

- 1. COVER PAGE
- 2. INDEX
- 3. BLOCK DIAGRAM
- 4. POWER SEQUENCE BLOCK
- 5. PCB
- 6. SYSTEM POWER
- 7. SYSTEM POWER
- 8. SYSTEM POWER
- 9. SYSTEM POWER
- 10. SYSTEM POWER
- 11. SYSTEM POWER
- 12. SYSTEM POWER
- 13. SUPER I/O(KBC)
- 14. K/B & TP/B CONN
- 15. FAN & THERMAL
- 16. LAN
- 17. RJ45 & TRANSFORMER
- 18. AUDIO CODEC
- 19. SPDIF & MIC & HP
- 20. CARDREADER
- 21. LCM
- 22. RGB CONN
- 23. SATA HDD & ODD
- 24. USB
- 25. WLAN
- 26. LID SW
- 27. LED

PAGE

- 28. DDR2 DIMM0
- 29. DDR2 DIMM1
- 30. APU-1
- 31. APU-2
- 32. APU-3
- 33. APU-4
- 34. FCH-1
- 35. FCH-2
- 36. FCH-3
- 37. FCH-4
- 38. EMI
- 39. Power Board
- 40. VGA POWER
- 41. VGA
- 42. VGA
- 43. VGA
- 44. VGA
- 45. VGA
- 46. VGA
- 47. VRAM
- 48. VRAM

INVENTEC			
TITLE Berlin 10AD			
Index			
SIZE	CODE	DOC. NUMBER	REV
A3	CS	1310A2333201	X01
CHANGE by		DATE	SHEET
Devin Hsieh		28-Jul-2010	2 OF 48

AMD BRAZOS PLATFORM

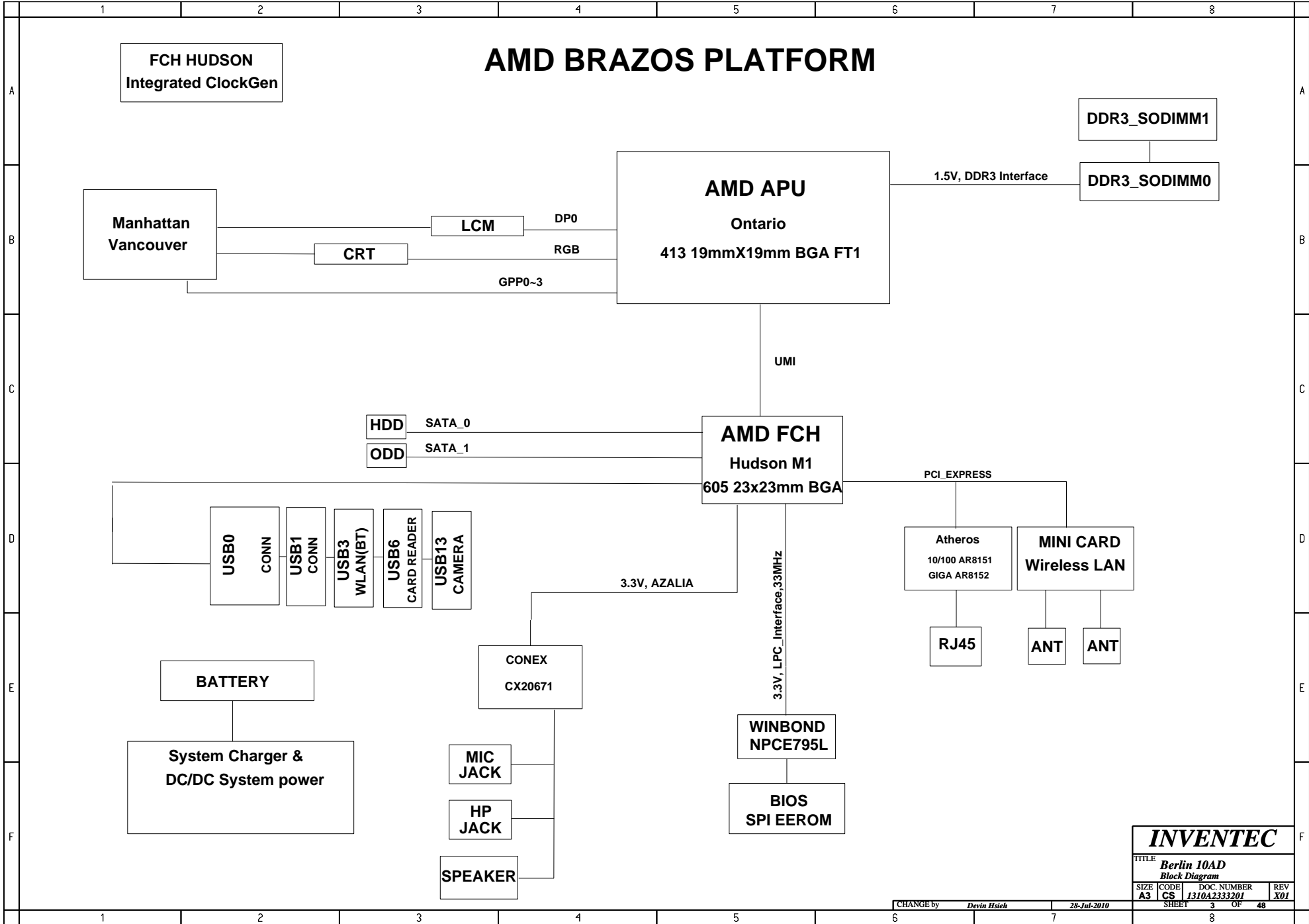

INVENTEC			
TITLE Berlin 10AD			
Block Diagram			
SIZE	CODE	DOC. NUMBER	REV
A3	CS	1310A2333201	X01
CHANGE by <i>Devin Hsieh</i> 28-Jul-2010			SHEET 3 OF 48

Update by power budget

INVENTEC

TITLE			
Berlin 10AD			
<i>Power Sequence Block</i>			
SIZE	CODE	DOC. NUMBER	REV
A3	CS	1310A2333201	X01
SHEET		4	OF 48

CHANGE by *Devin Hsieh* 2-Nov-2009

8

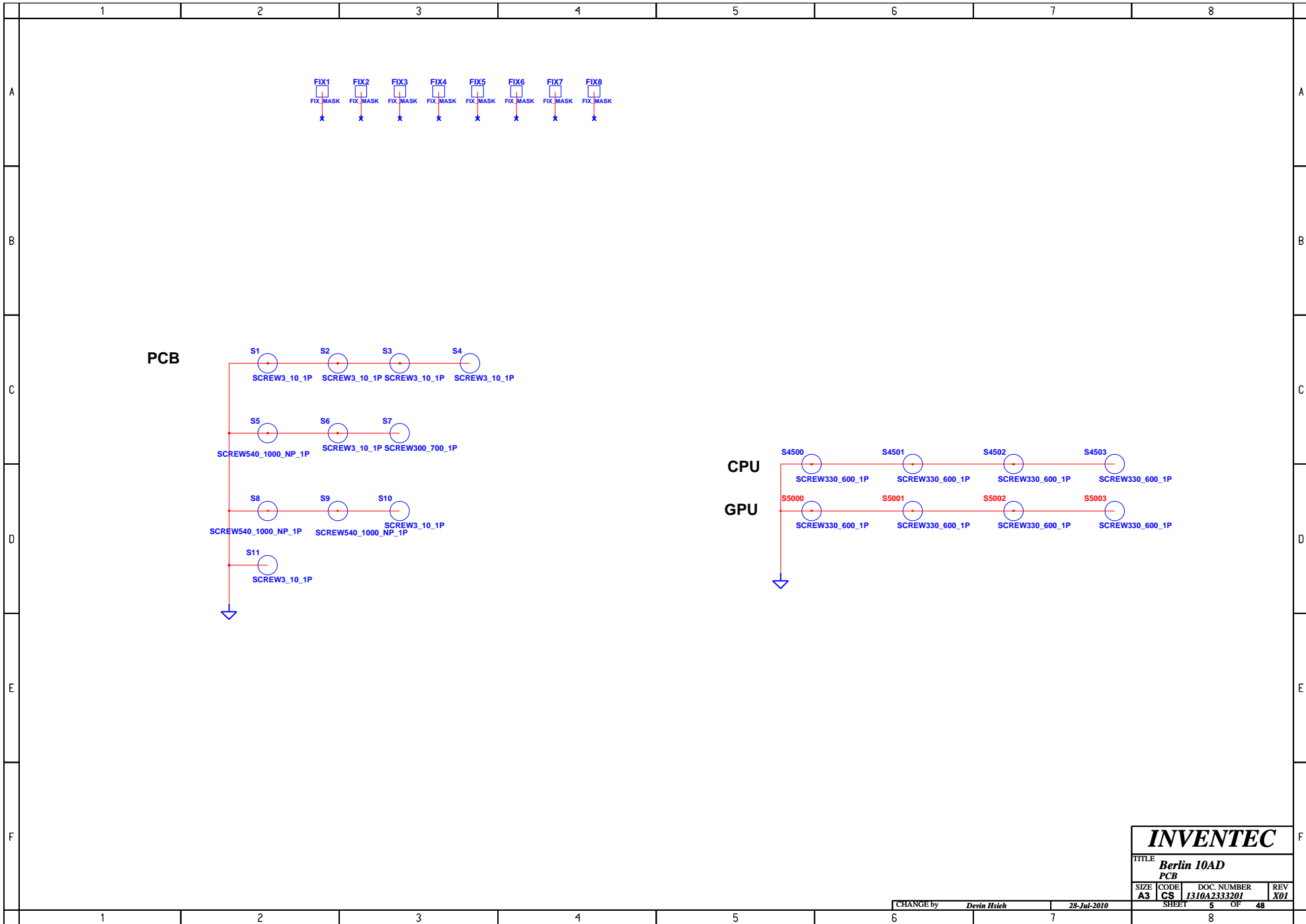

INVENTEC			
TITLE Berlin 10AD			
PCB			
SIZE	CODE	DOC. NUMBER	REV
A3	CS	1310A2333201	X01

CHANGE by	Devin Hsieh	28-Jul-2010	SHEET	5	OF	48
-----------	-------------	-------------	-------	---	----	----

FUSE6000
65W-75W 8A(6036A0003401)
90W 10A(6036A0002901)
120W 12A(6036A0006001)

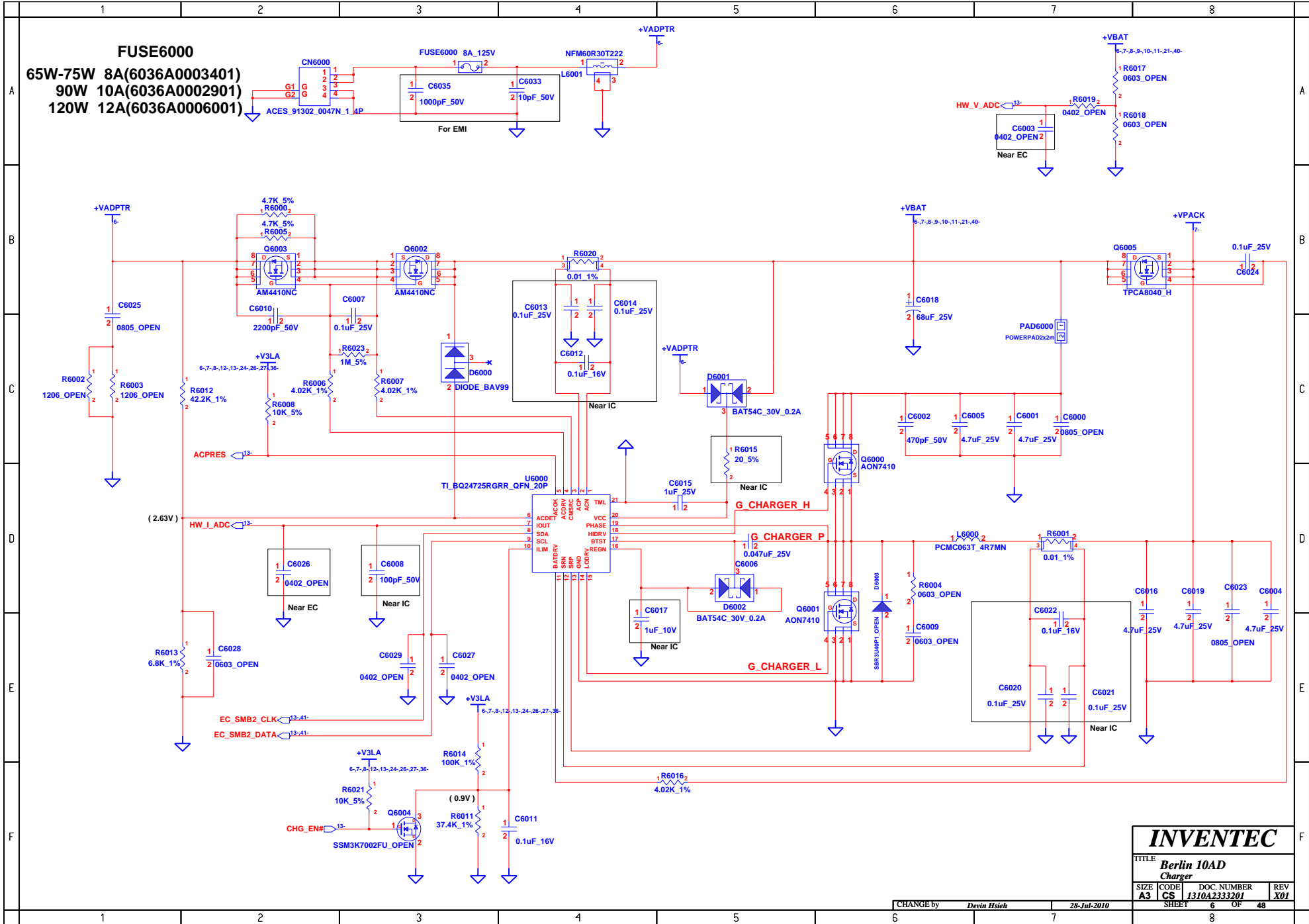

INVENTEC			
TITLE Berlin 10AD			
Charger			
SIZE A3	CODE CS	DOC. NUMBER 1310A2333201	REV X01
CHANGE by <i>Devlin Hsieh</i>		28-Jul-2010	
SHEET 6		OF 48	

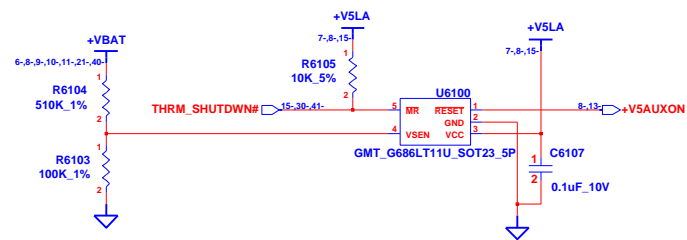
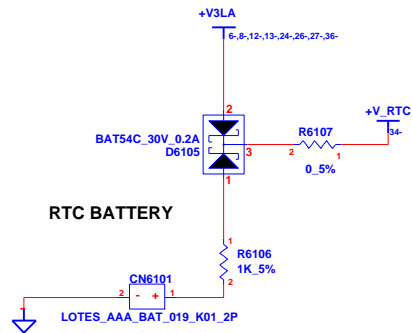
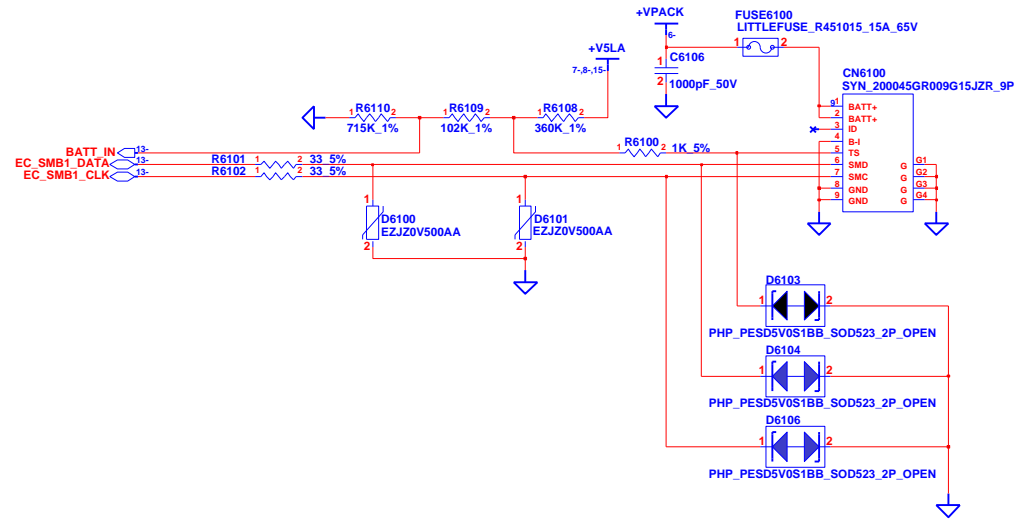

INVENTEC

TITLE			
Berlin 10AD			
Battery, Reset IC			
SIZE	CODE	DOC NUMBER	REV
A3	CS	1310A2333201	X01
CHANGE by		SHEET	
Devlin Hsieh		7 OF 48	

2-Nov-2009

+V3LA +V3A +V5A

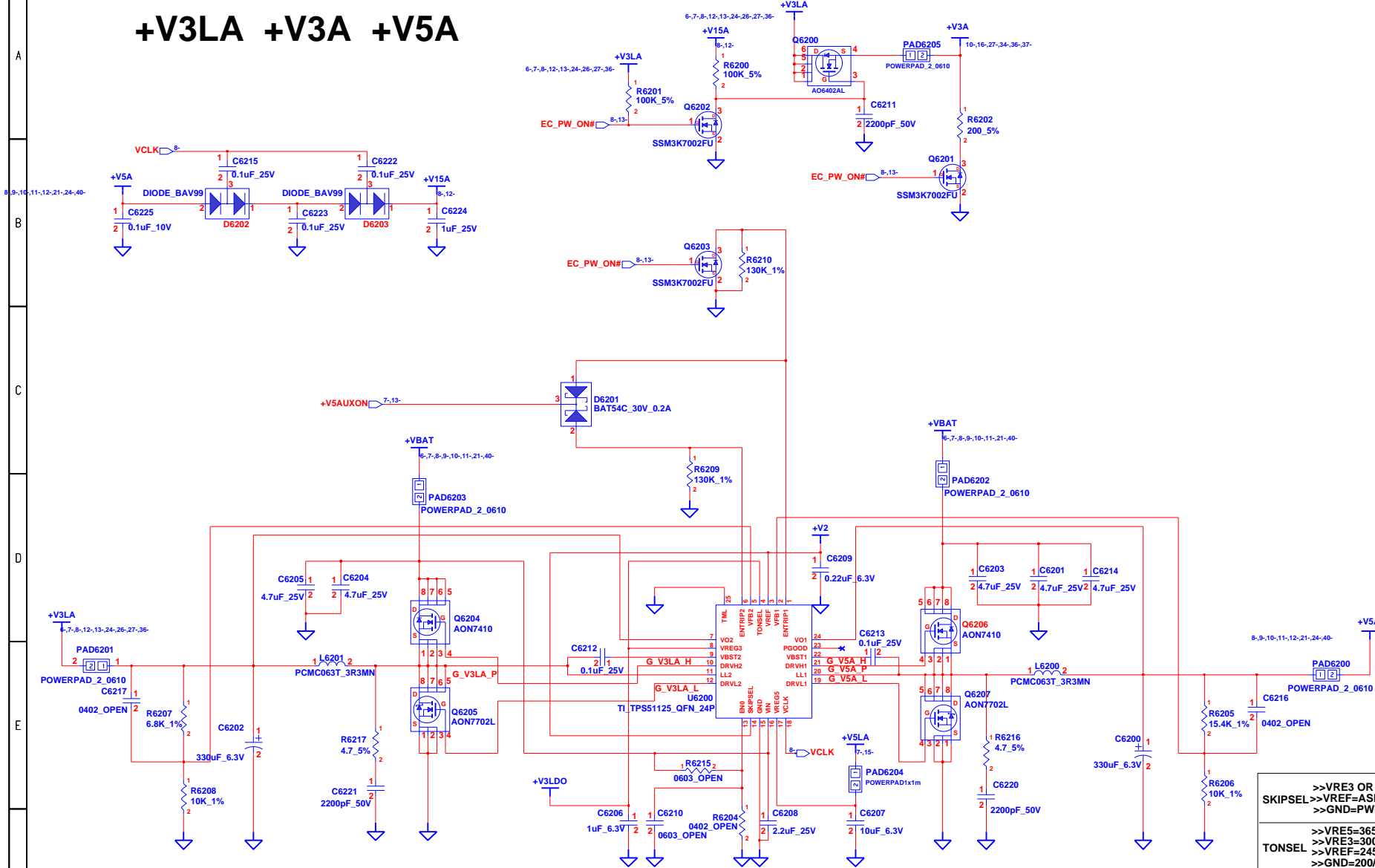

>>VRE3 OR VRE5=OOA
 SKIPSEL>>VREF=ASKIP
 >>GND=PWM

 >>VRE5=365/460
 >>VRE3=300/375
 >>VREF=245/305
 >>GND=200/250

INVENTEC

TITLE			
Berlin 10AD			
+V3LA, +V3A, +V5A, +V2.5S			
SIZE	CODE	DOC. NUMBER	REV
A3	CS	1310A2333201	X01

+V1.8S +V0.75S +V1.5

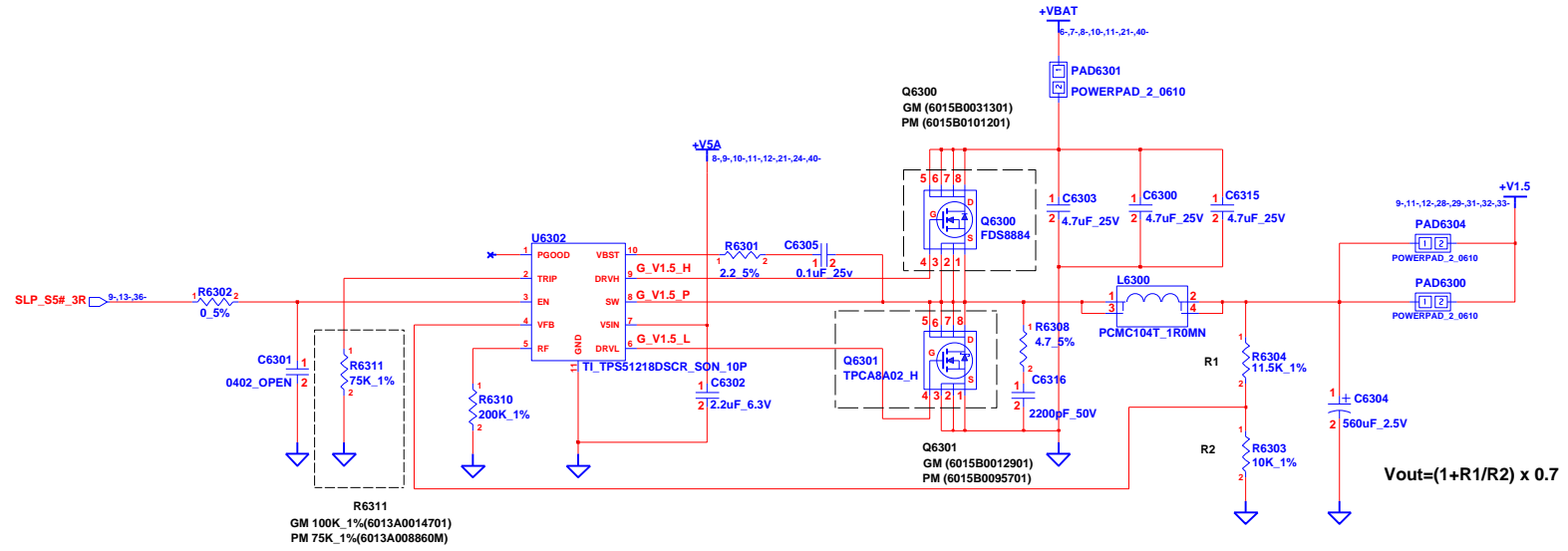

$$V_{out} = (1 + R1/R2) \times 0.7$$

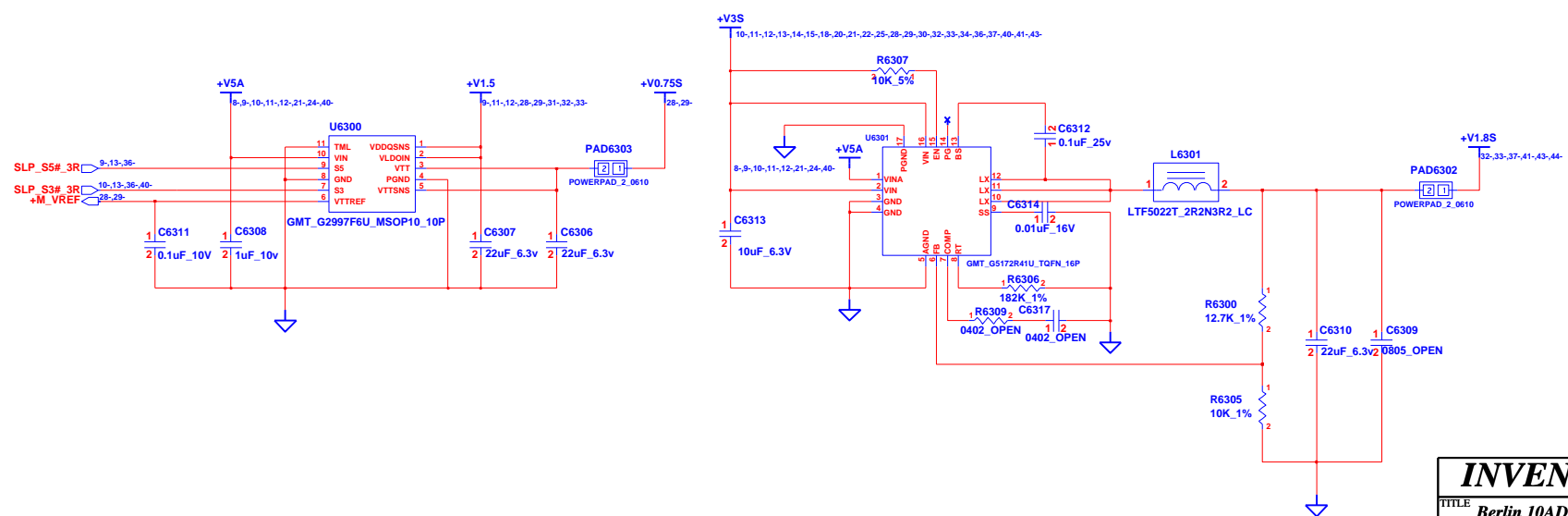

INVENTEC			
TITLE Berlin 10AD			
+CPU_VDDR, +V0.75, +V1.5			
SIZE	CODE	DOC NUMBER	REV
A3	CS	1310A2333201	X01
CHANGE by		2-Nov-2009	
SHEET		9 OF 48	

+V1.1A +V1S +V1.1S

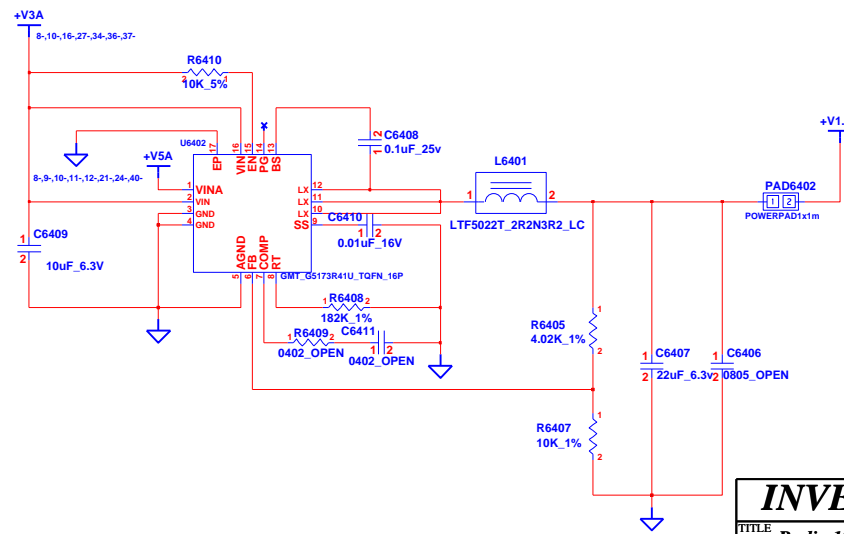
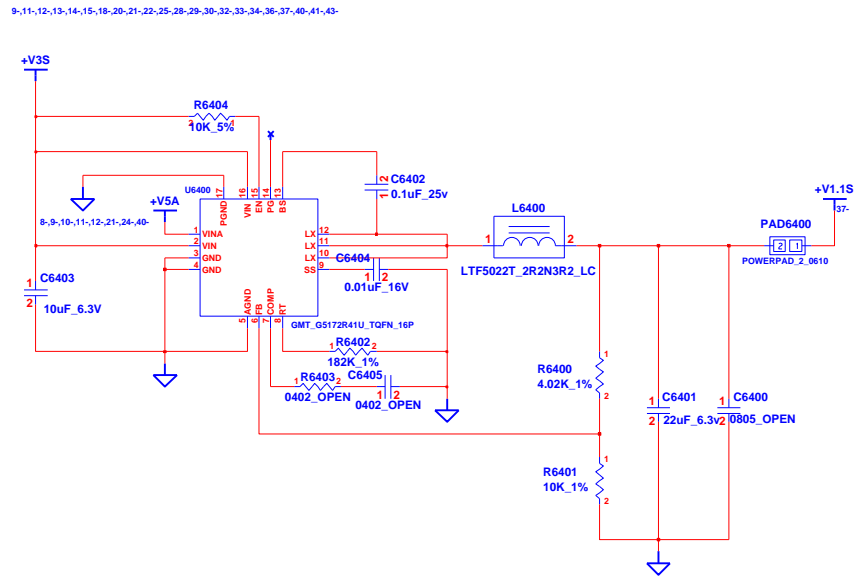
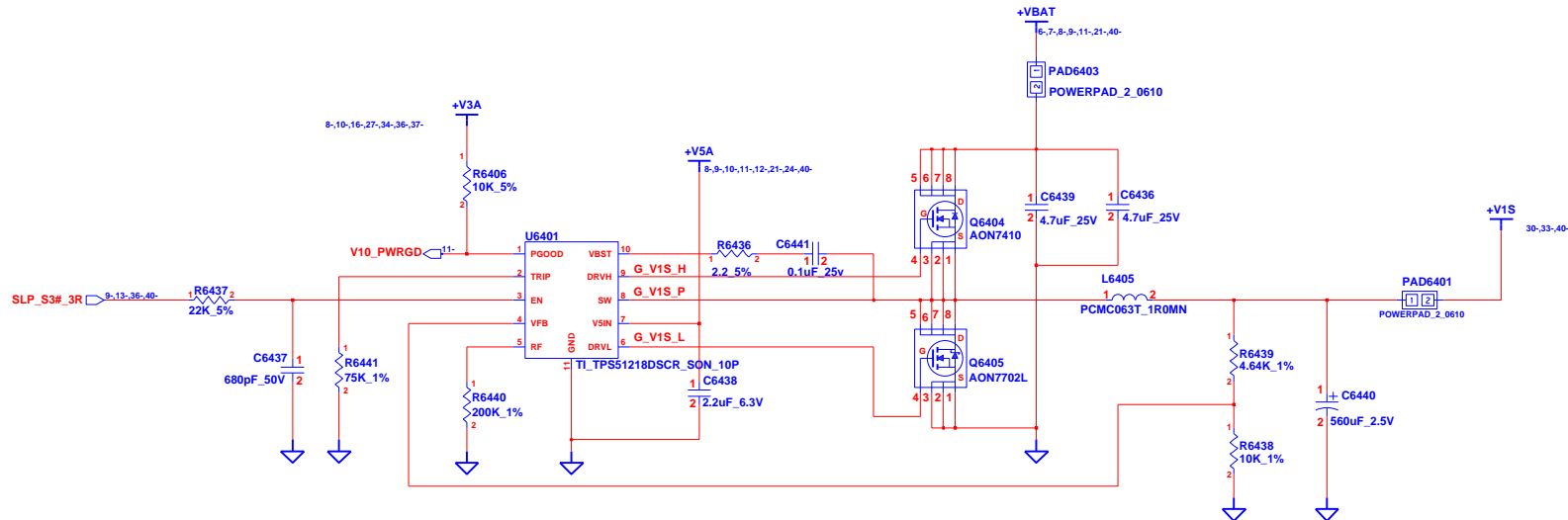

INVENTEC			
TITLE Berlin 10AD			
+V1.1A, +V1.1S, +V1.8S			
SIZE	CODE	DOC NUMBER	REV
A3	CS	1310A2333201	X01
CHANGE by		2-Nov-2009	
SHEET		10 OF 48	

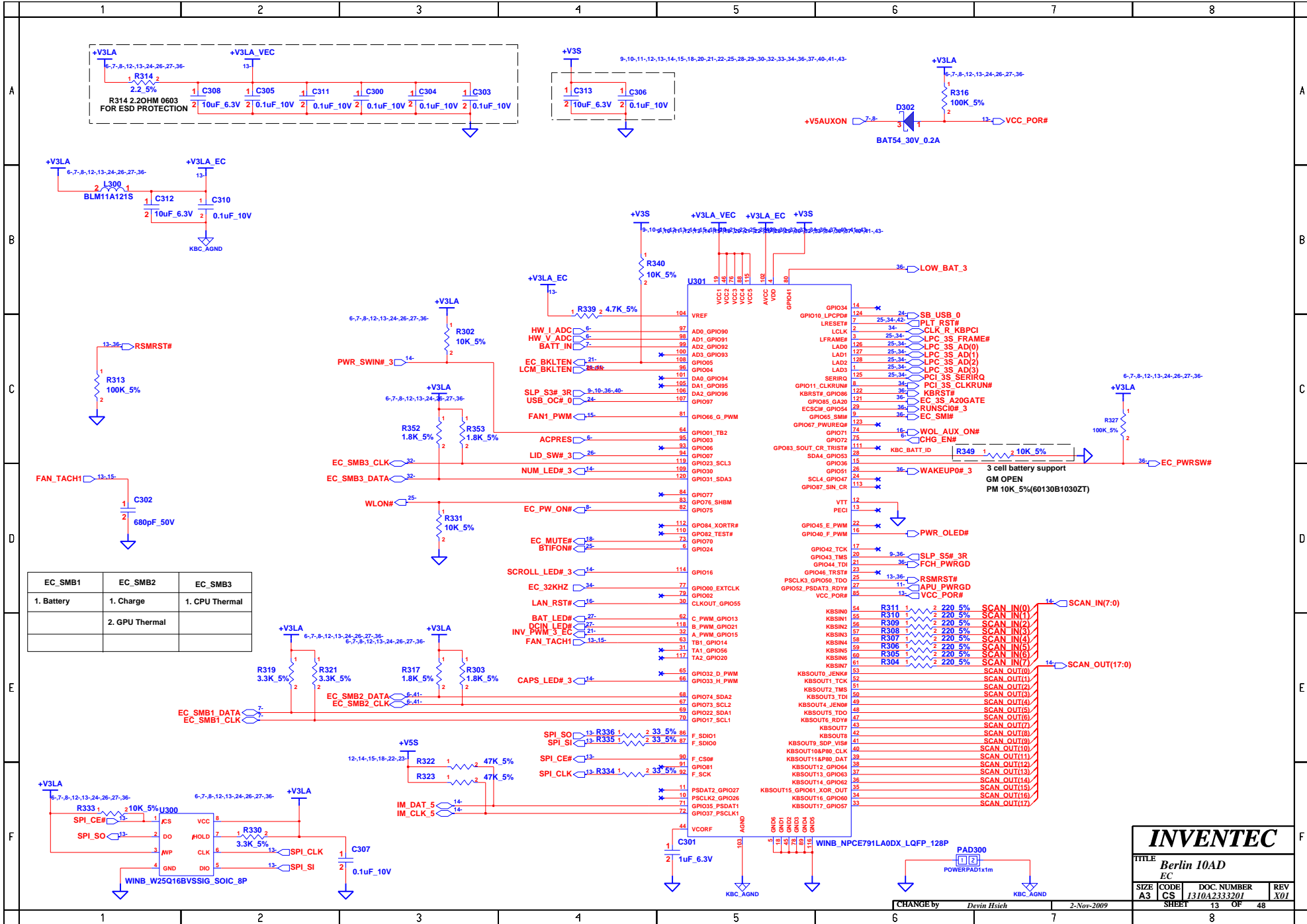

INVENTEC

TITLE
Berlin 10AD
EC

SIZE A3	CODE CS	DOC. NUMBER 1310A2333201	REV X01
------------	------------	-----------------------------	------------

CHANGE by Devin Hsieh 2-Nov-2009

SHEET 13 OF 48

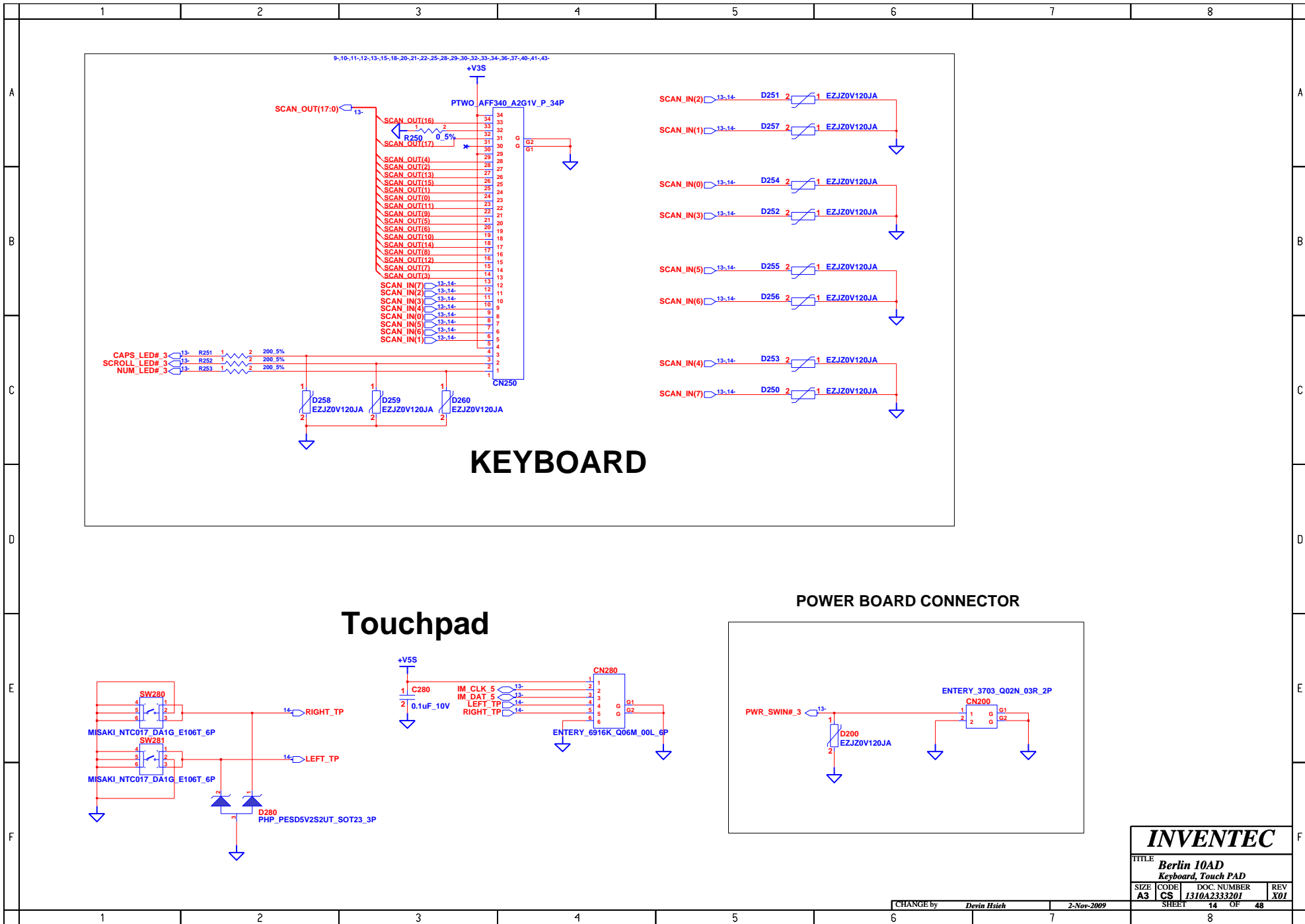

KEYBOARD

Touchpad

POWER BOARD CONNECTOR

INVENTEC

TITLE
Berlin 10AD
 Keyboard, Touch PAD

SIZE A3	CODE CS	DOC. NUMBER 1310A2333201	REV X01
-------------------	-------------------	------------------------------------	-------------------

CHANGE by *Devin Hsieh* 2-Nov-2009

SHEET 14 OF 48

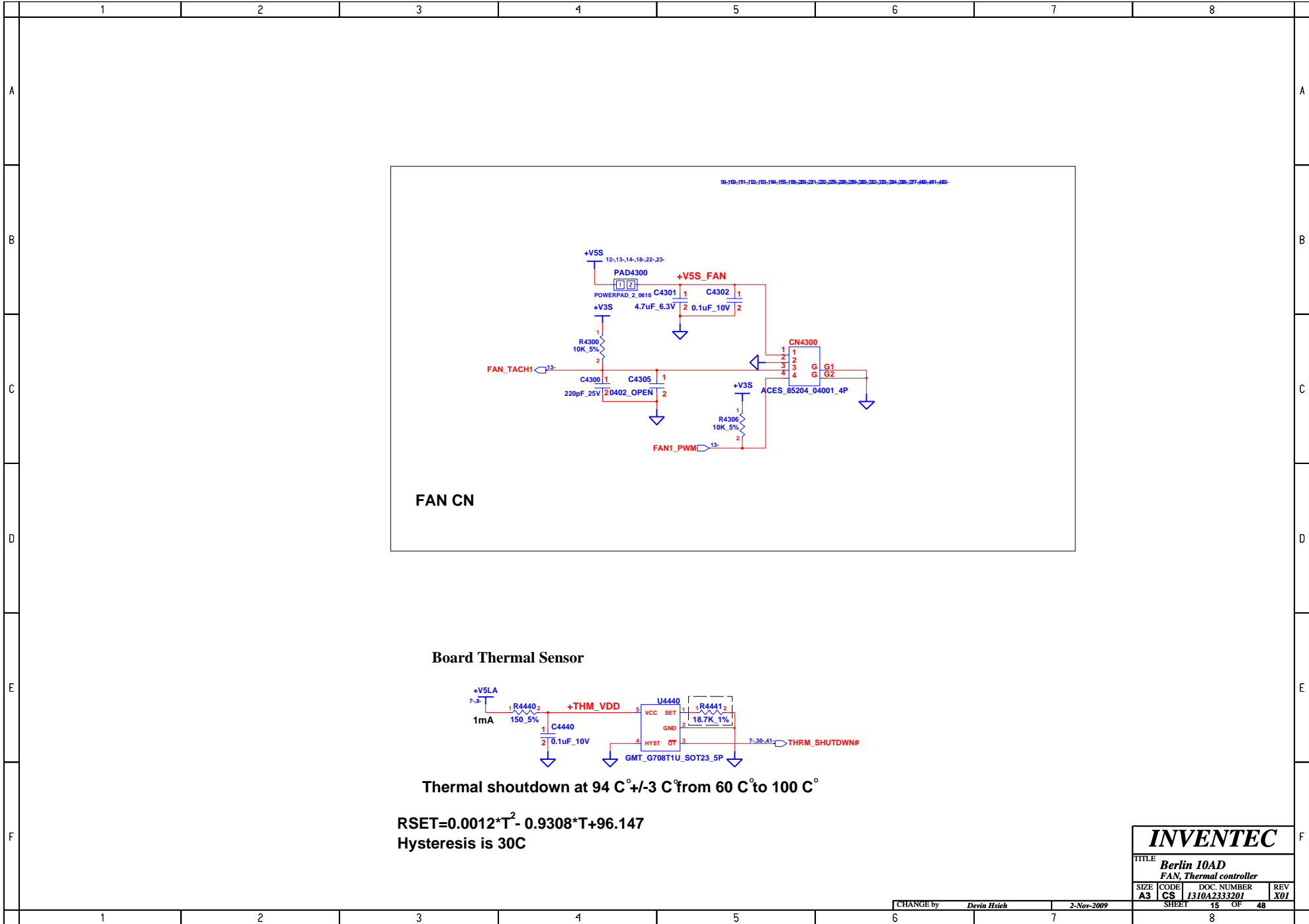

FAN CN

Board Thermal Sensor

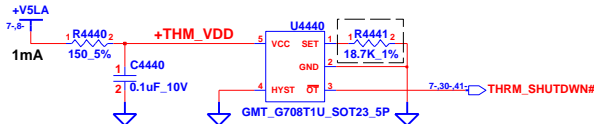

Thermal shutdown at 94 C° +/-3 C° from 60 C° to 100 C°

$RSET=0.0012*T^2 - 0.9308*T+96.147$
Hysteresis is 30C

INVENTEC			
TITLE Berlin 10AD FAN, Thermal controller			
SIZE A3	CODE CS	DOC. NUMBER 1310A2333201	REV X01
CHANGE by <i>Devin Hsieh</i>		2-Nov-2009	
SHEET 15		OF 48	

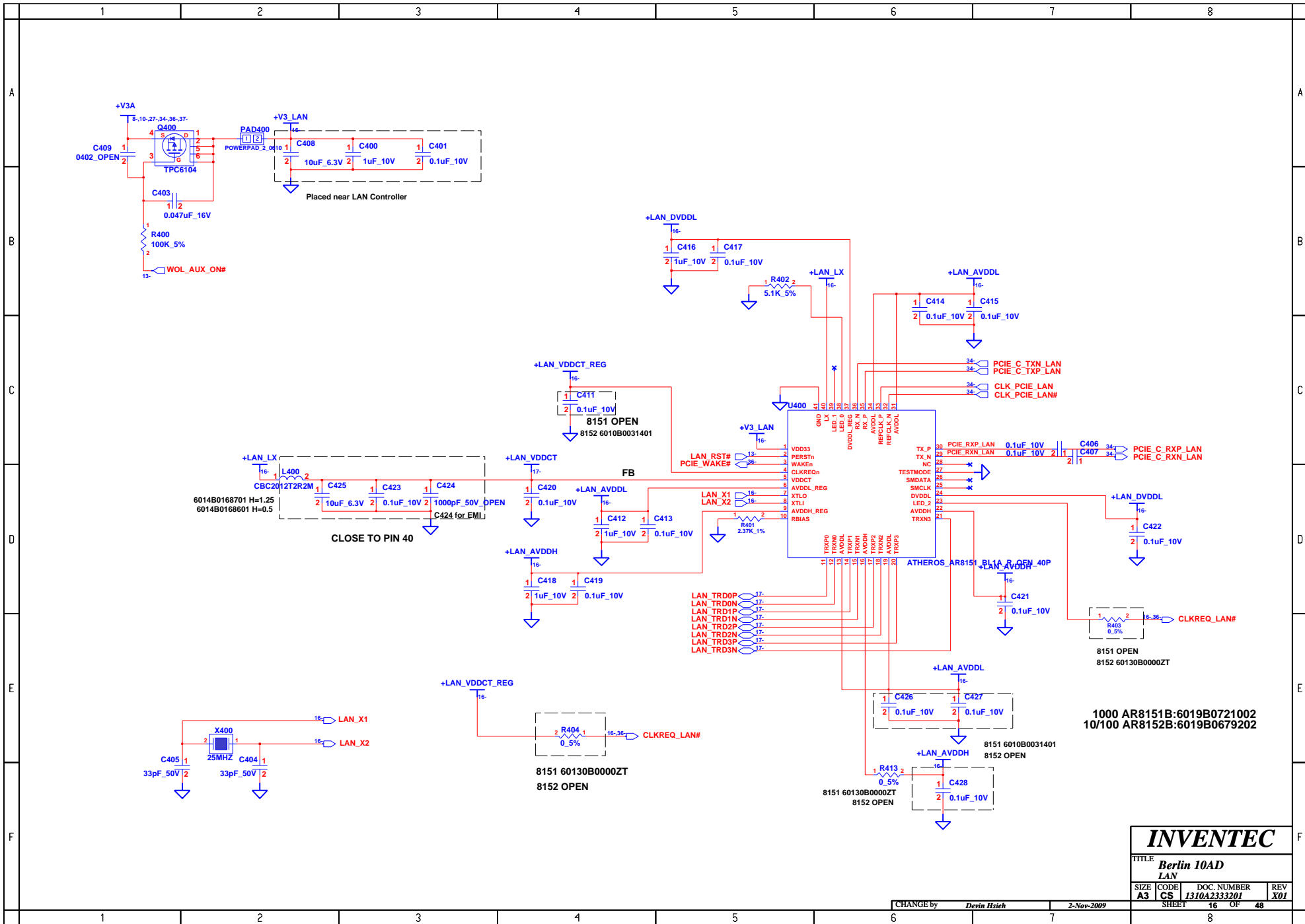

INVENTEC			
TITLE Berlin 10AD LAN			
SIZE A3	CODE CS	DOC. NUMBER 1310A2333201	REV X01
CHANGE by <i>Devin Hsieh</i>		2-Nov-2009	
SHEET 16		OF 48	

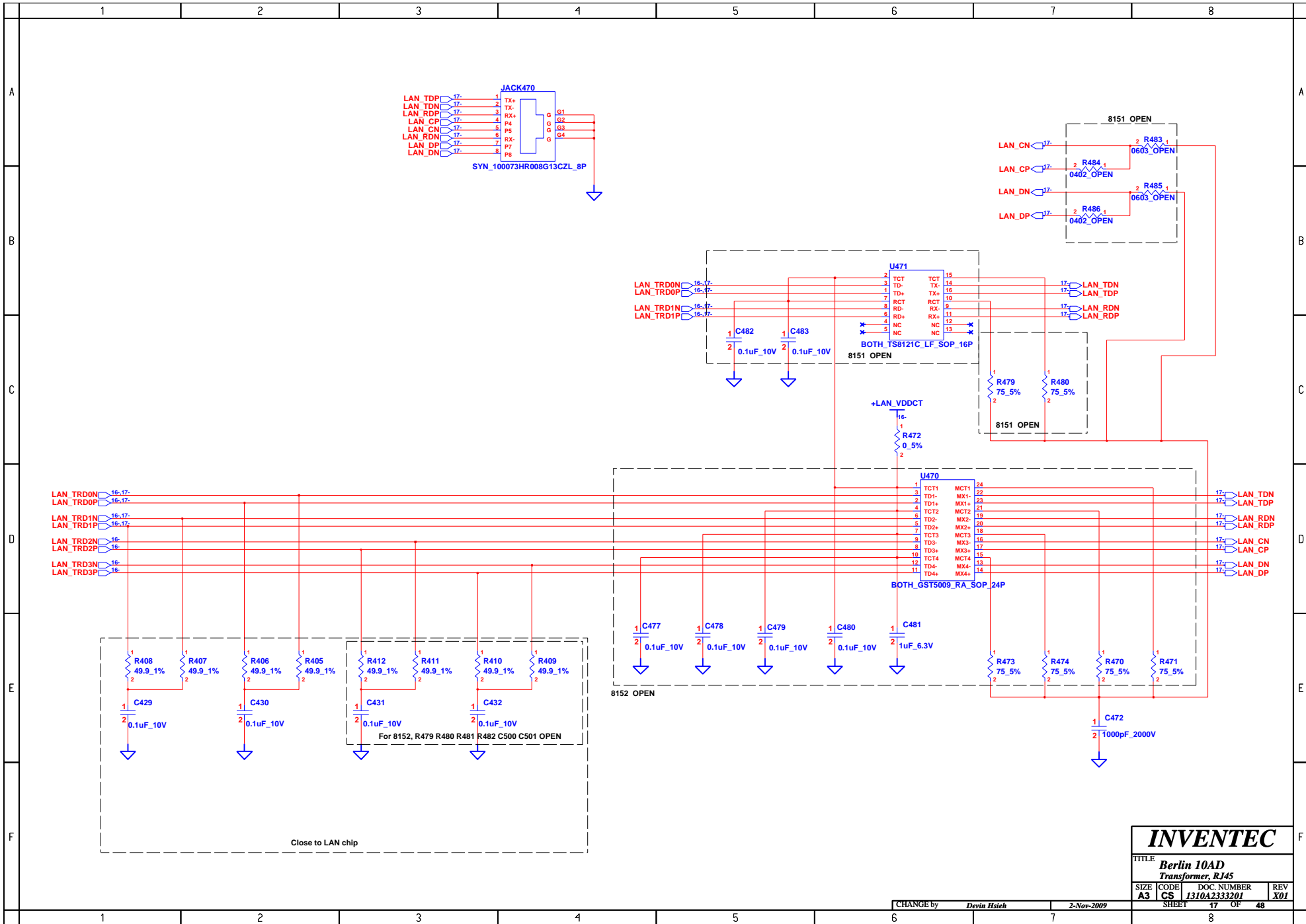

INVENTEC			
TITLE Berlin 10AD Transformer, RJ45			
SIZE A3	CODE CS	DOC. NUMBER 1310A2333201	REV X01
CHANGE by <i>Devin Hsieh</i>		2-Nov-2009	
SHEET 17		OF 48	

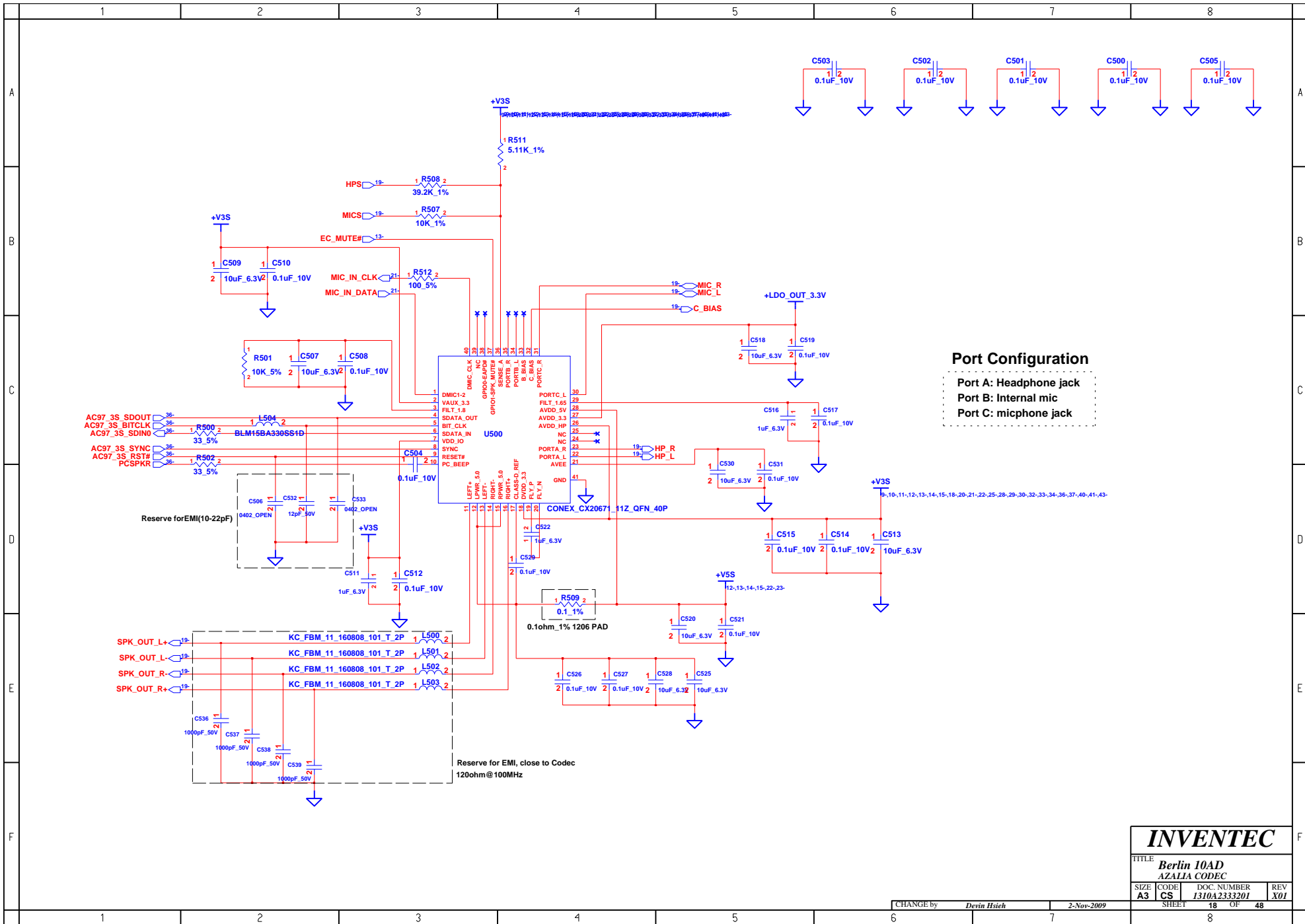

Port Configuration

- Port A: Headphone jack
- Port B: Internal mic
- Port C: microphone jack

INVENTEC

TITLE
Berlin 10AD
AZALIA CODEC

SIZE A3	CODE CS	DOC. NUMBER 1310A2333201	REV X01
-------------------	-------------------	------------------------------------	-------------------

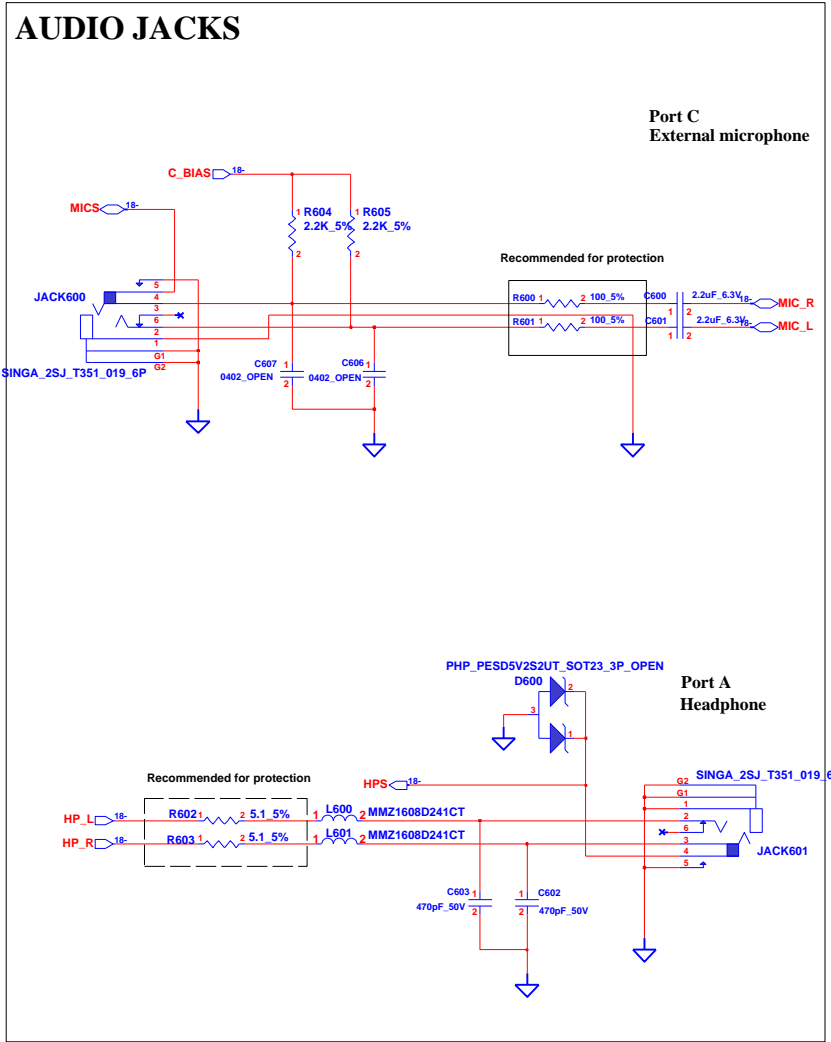
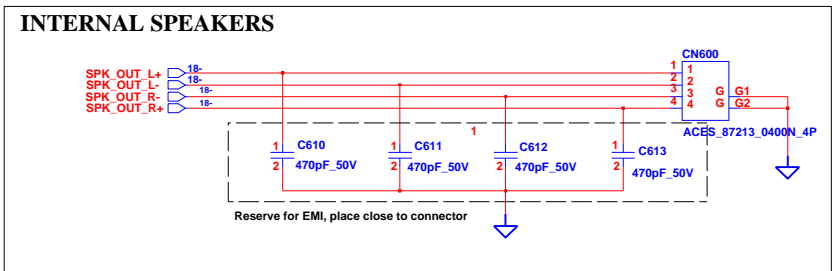

INVENTEC			
TITLE Berlin 10AD MIC & SPEAKER			
SIZE A3	CODE CS	DOC. NUMBER I310A2333201	REV X01
CHANGE by <i>Devin Hsieh</i>		2-Nov-2009	
SHEET		19 OF 48	

CARD READER & USB BOARD

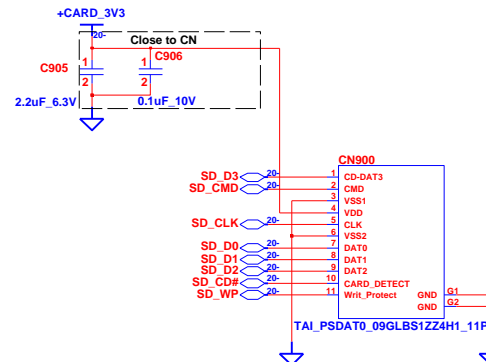
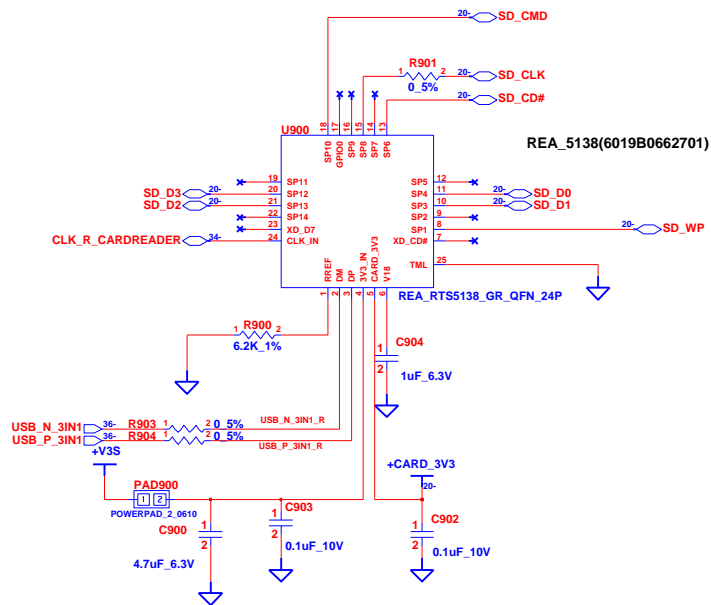

INVENTEC

TITLE
Berlin 10AD
MDC

SIZE A3	CODE CS	DOC. NUMBER 1310A2333201	REV X01
SHEET		20 OF	48

CHANGE by *Devin Hsieh* 28-Jul-2010

8

GM/PM CO-LAYOUT

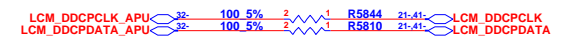
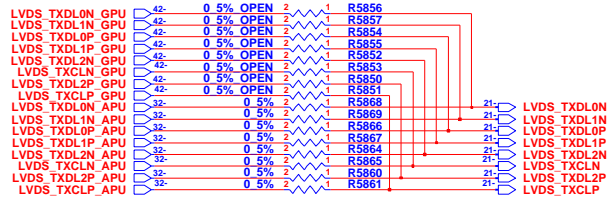

LCM DDC PU values

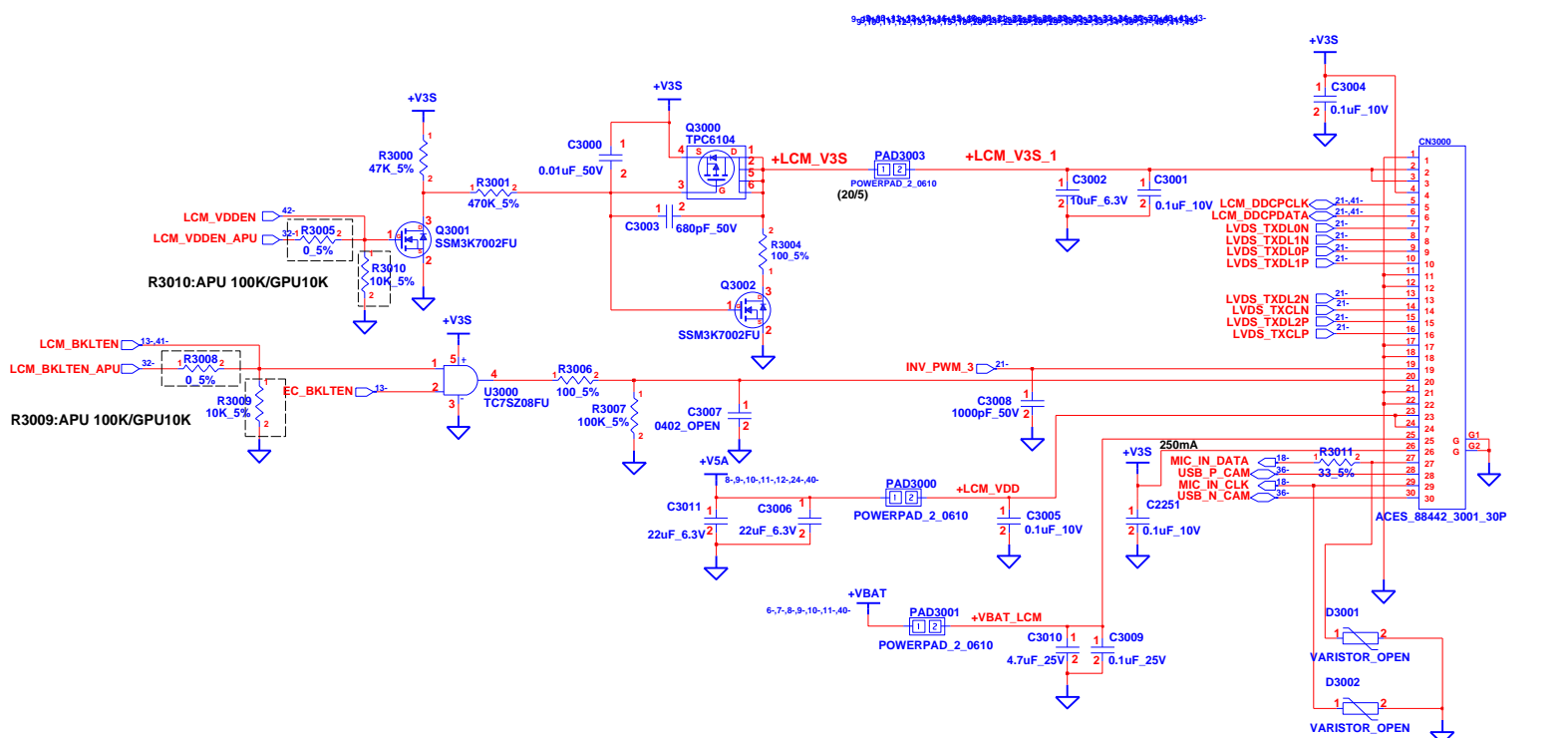
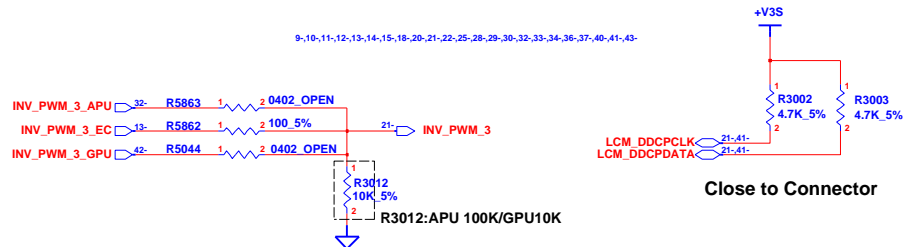

INVENTEC			
TITLE Berlin 10AD			
LCM			
SIZE A3	CODE CS	DOC. NUMBER 1310A2333201	REV X01
CHANGE by <i>Devlin Hsieh</i>		2-Nov-2009	
SHEET 21		OF 48	

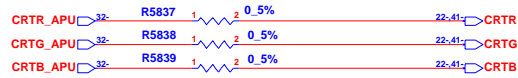

GM/PM CO-LAYOUT

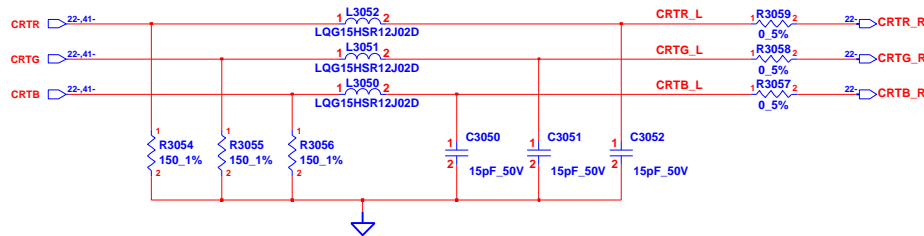

Level-shift PU values

	3 V	5 V
FCH	4.7K_5% 60130B4720ZT	4.7K_5% 60130B4720ZT
GPU	10K_5% 60130B1030ZT	2K_5% 60130B2020ZT

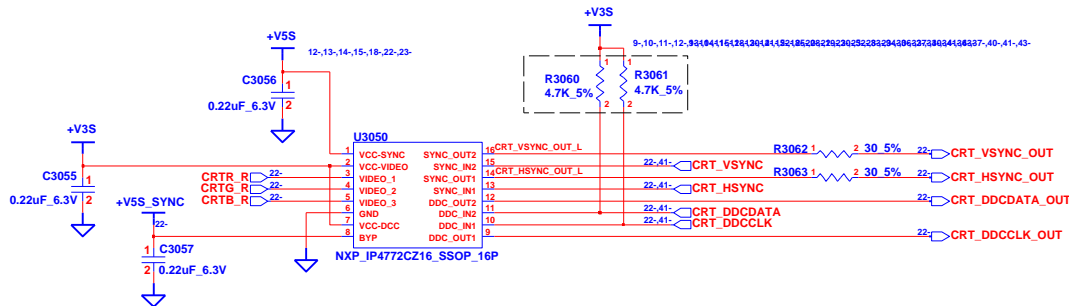
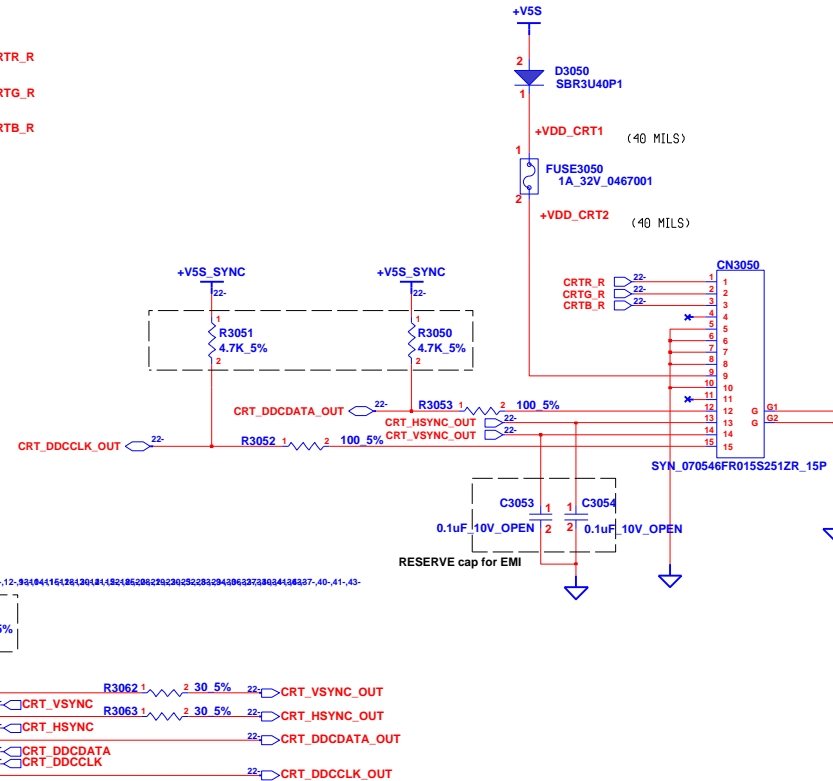

INVENTEC

TITLE			
Berlin 10AD			
CRT			
SIZE	CODE	DOC. NUMBER	REV
A3	CS	1310A2333201	X01
SHEET		22	OF 48

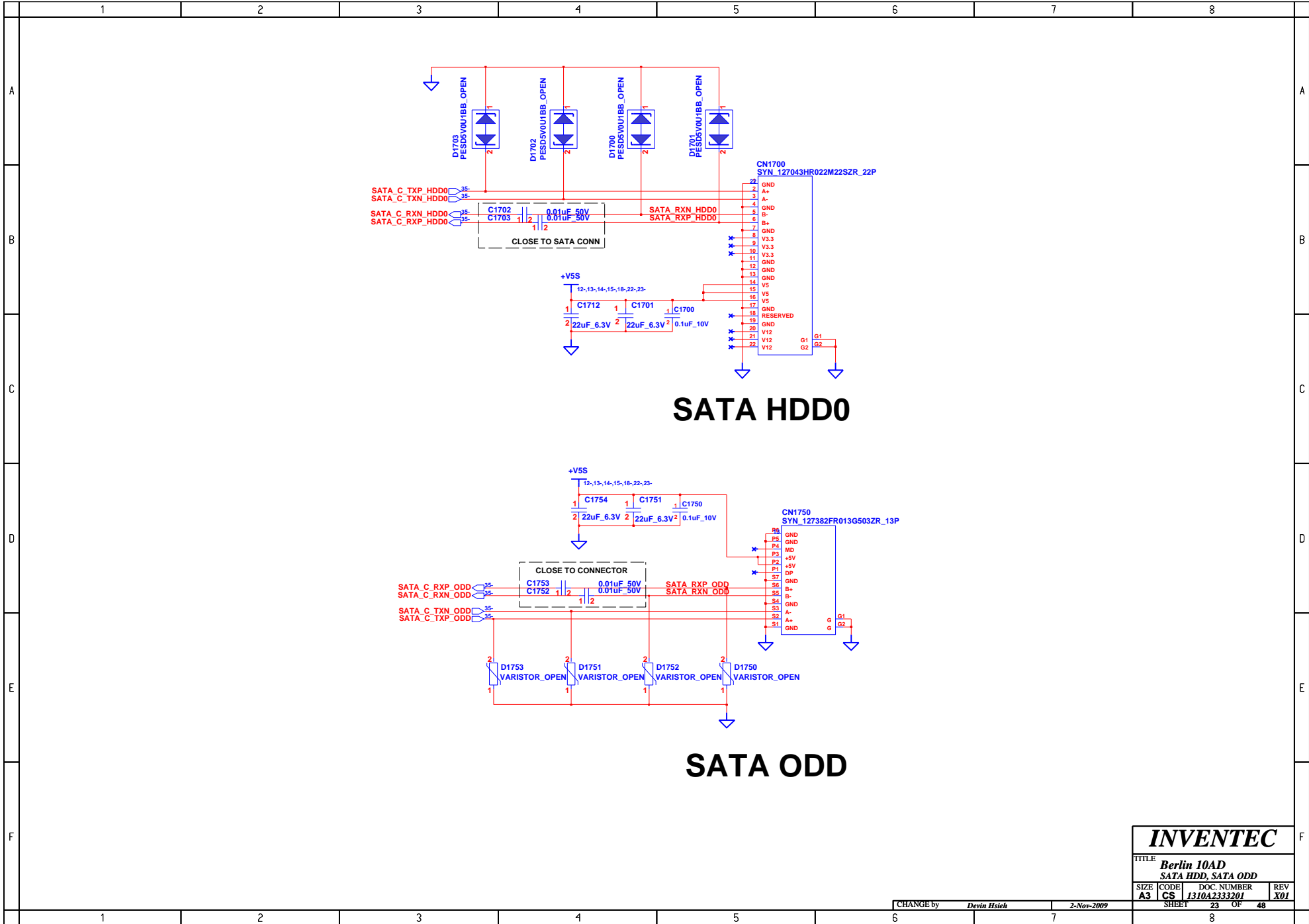

INVENTEC

TITLE			
Berlin 10AD SATA HDD, SATA ODD			
SIZE	CODE	DOC. NUMBER	REV
A3	CS	1310A2333201	X01
CHANGE by		SHEET	OF
Devin Hsieh		23	48

2-Nov-2009

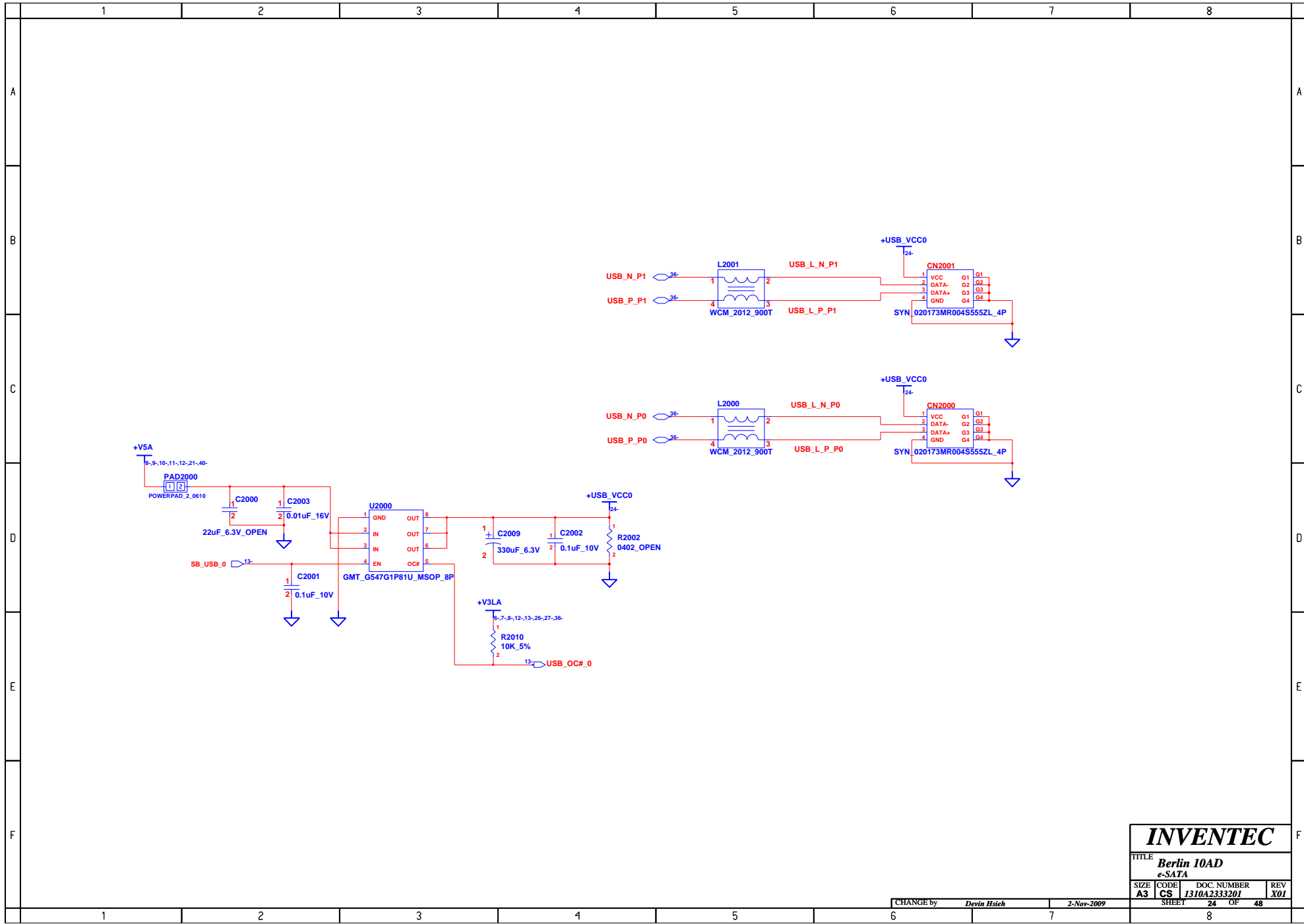

INVENTEC			
TITLE Berlin 10AD e-SATA			
SIZE A3	CODE CS	DOC. NUMBER 1310A2333201	REV X01
CHANGE by <i>Devin Hsieh</i>		2-Nov-2009	SHEET 24 OF 48

Wireless & BT & Debug card

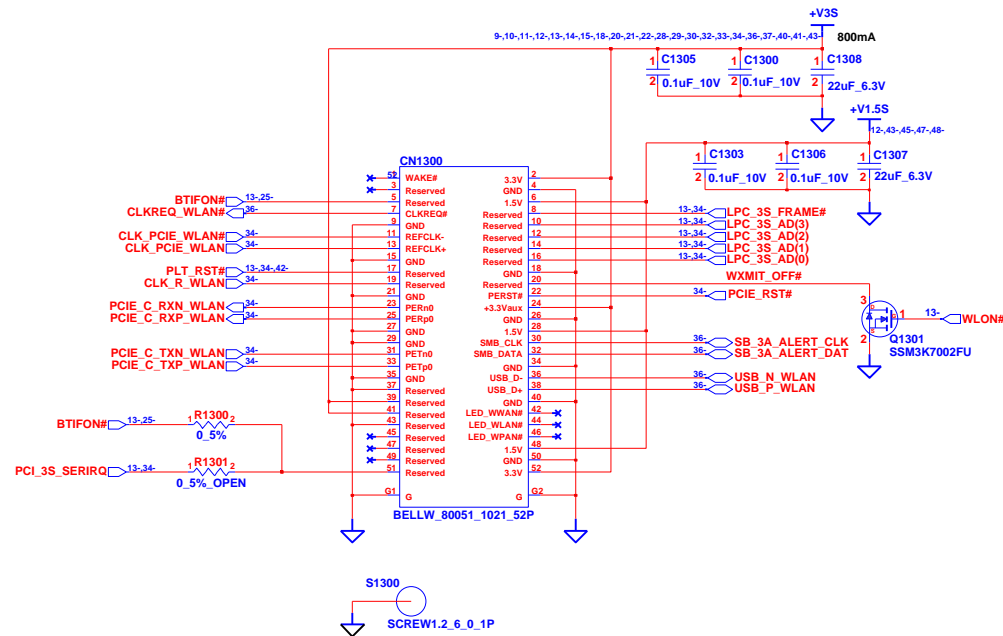

INVENTEC

TITLE			
Berlin 10AD			
WLAN			
SIZE	CODE	DOC. NUMBER	REV
A3	CS	1310A2333201	X01
CHANGE by		SHEET	OF
Devlin Hsieh		25	48

2-Nov-2009

HALL SENSOR

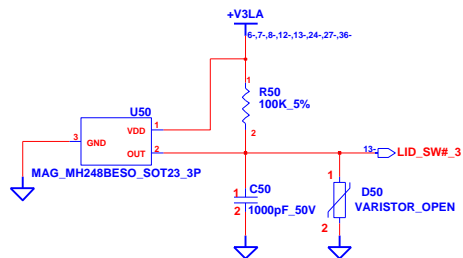

INVENTEC

TITLE			
Berlin 10AD			
HALL SENSOR			
SIZE	CODE	DOC. NUMBER	REV
A3	CS	1310A2333201	X01
SHEET		26	OF 48

CHANGE by Devin Hsieh 2-Nov-2009

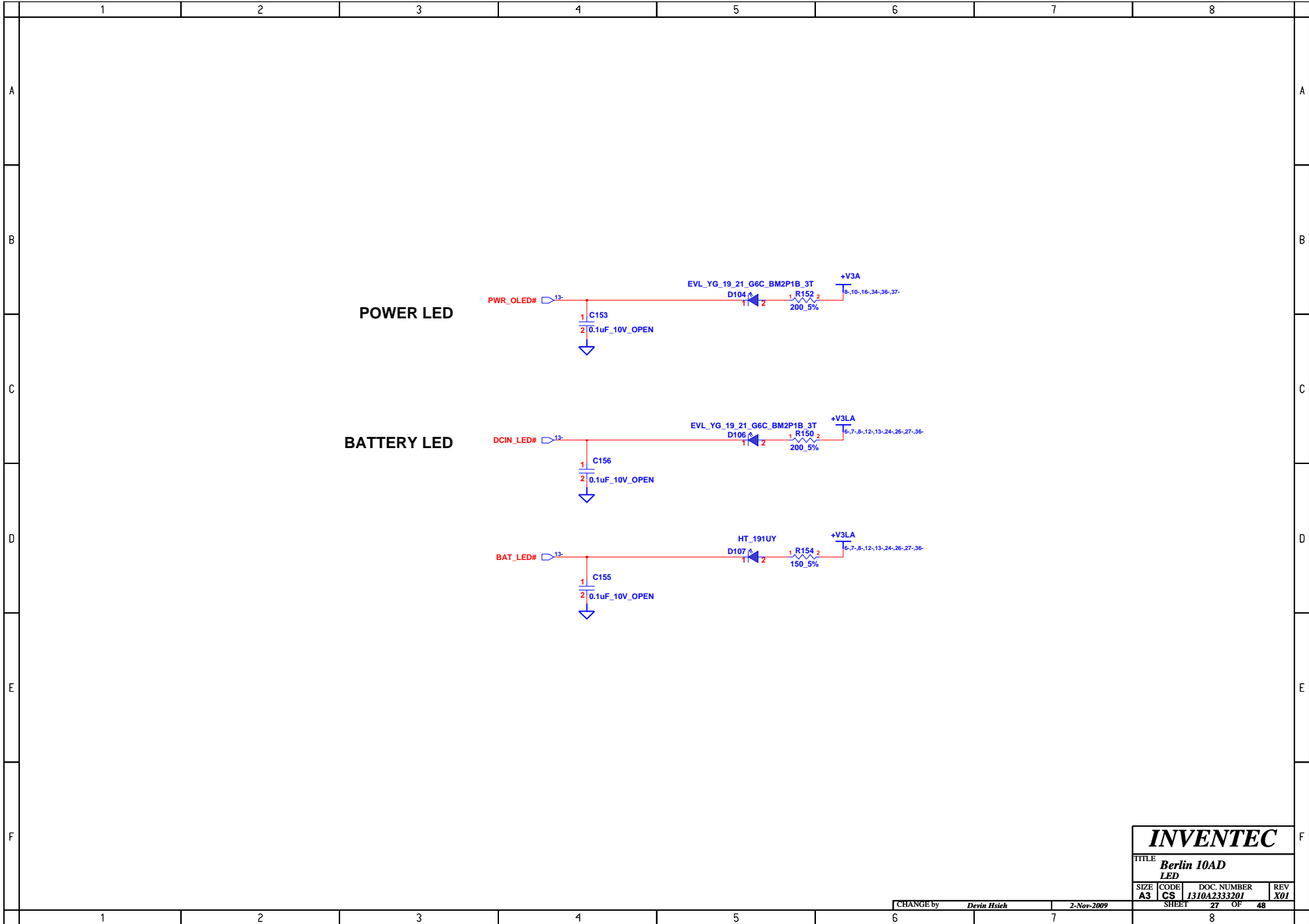

INVENTEC

TITLE **Berlin 10AD LED**

SIZE A3	CODE CS	DOC. NUMBER 1310A2333201	REV X01
----------------	----------------	---------------------------------	----------------

CHANGE by *Devin Hsieh* 2-Nov-2009

SHEET 27	OF 48
-----------------	--------------

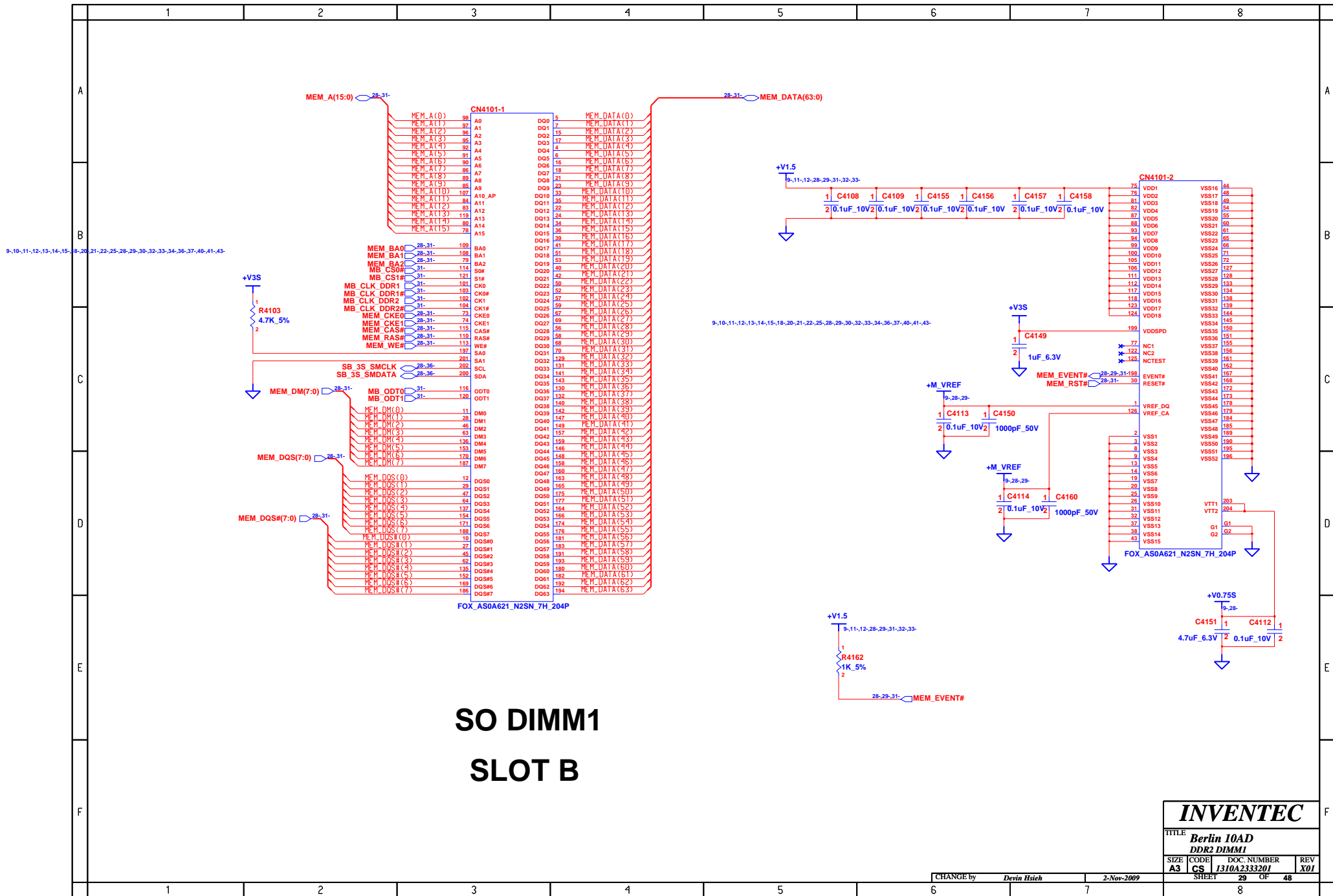

**SO DIMM1
SLOT B**

INVENTEC			
TITLE Berlin 10AD DDR2 DIMM1			
SIZE A3	CODE CS	DOC. NUMBER I310A2333201	REV X01
CHANGE by Devin Hsieh		2-Nov-2009	SHEET 29 OF 48

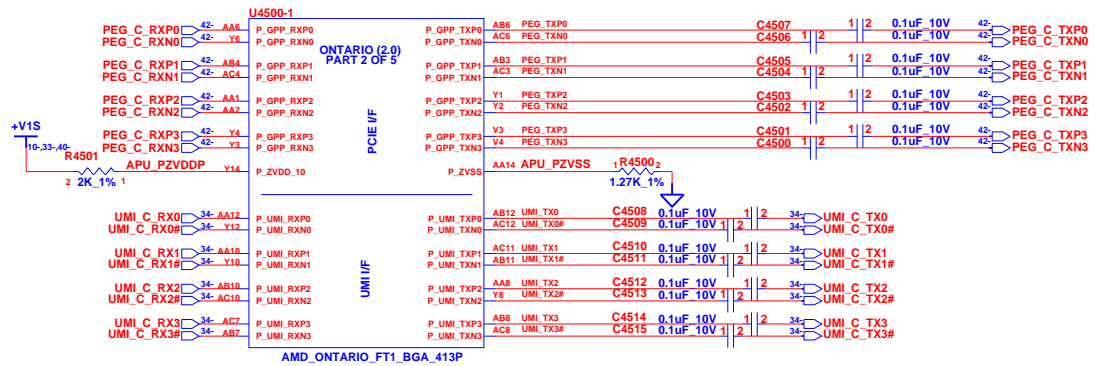
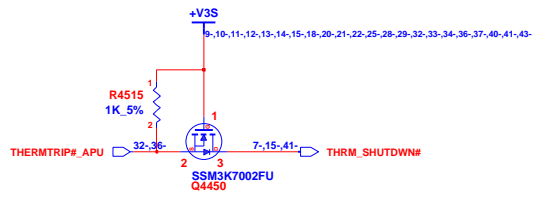

Layout: Add stitching caps if crossing plane split.

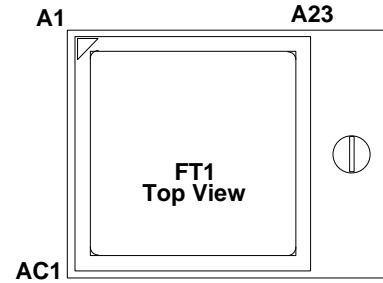

INVENTEC			
TITLE Berlin 10AD CPU-1			
SIZE A3	CODE CS	DOC. NUMBER 1310A2333201	REV X01
CHANGE by <i>Devin Hsieh</i>		3-May-2010	
SHEET		30	OF 48

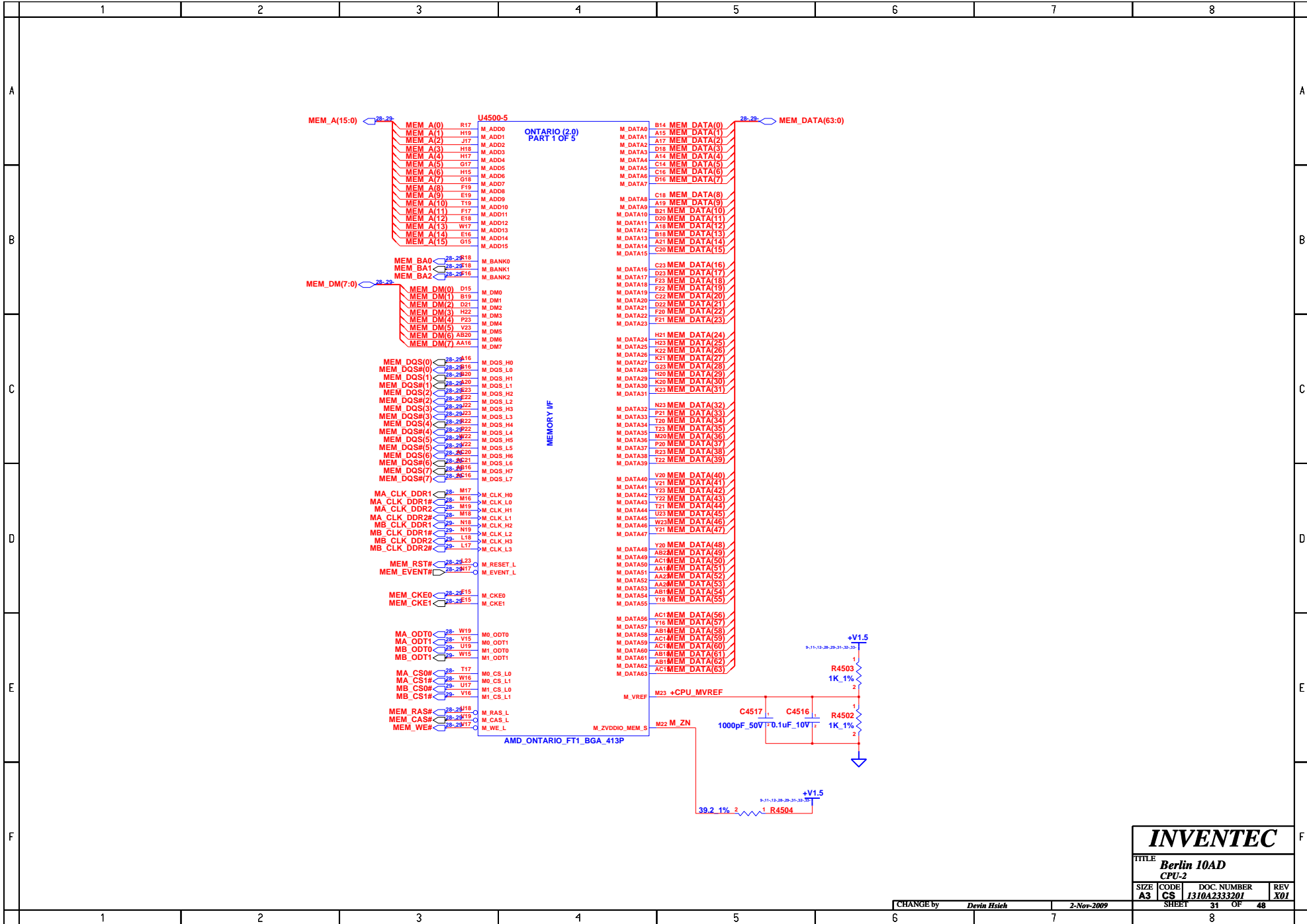

INVENTEC			
TITLE Berlin 10AD CPU-2			
SIZE A3	CODE CS	DOC. NUMBER 1310A2333201	REV X01
CHANGE by <i>Devlin Hsieh</i>		2-Nov-2009	
PAGE 31		OF 48	

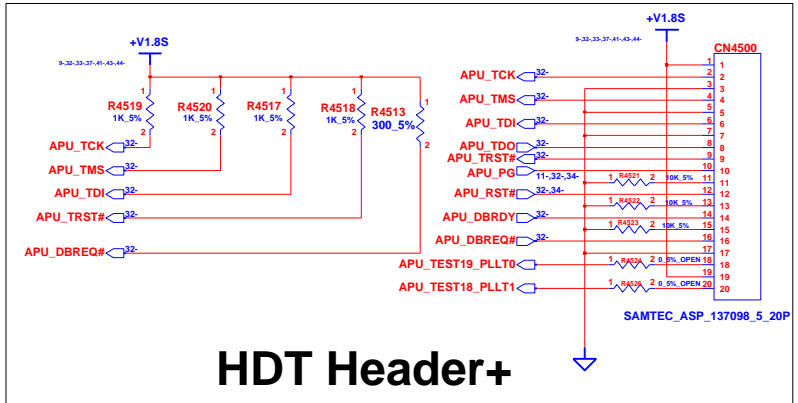
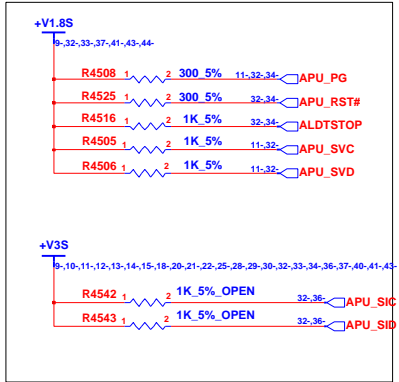
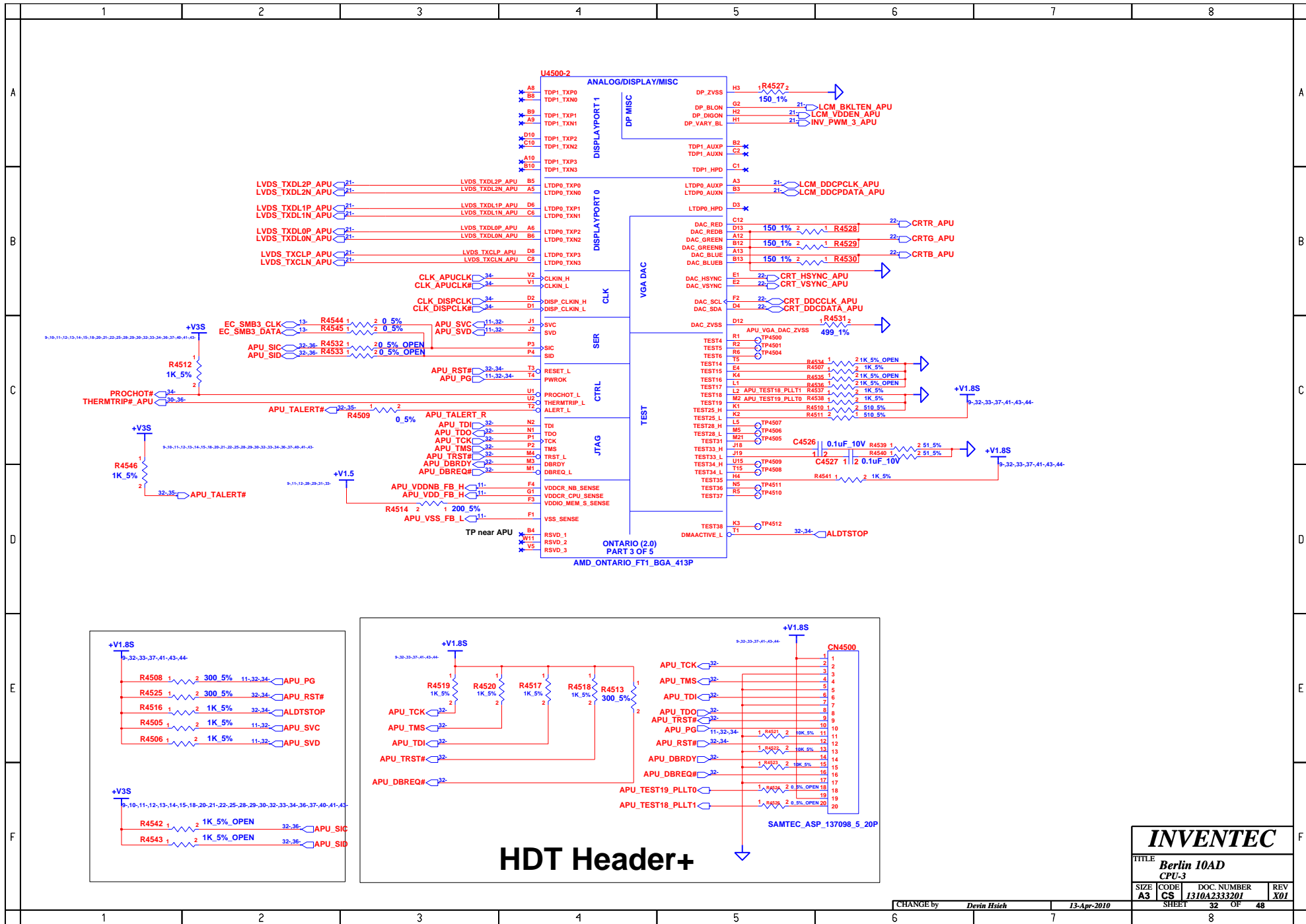

INVENTEC			
TITLE Berlin 10AD CPU-3			
SIZE A3	CODE CS	DOC. NUMBER 1310A2333201	REV X01
CHANGE by <i>Devlin Hsieh</i>		13-Apr-2010	
SHEET 32		OF 48	

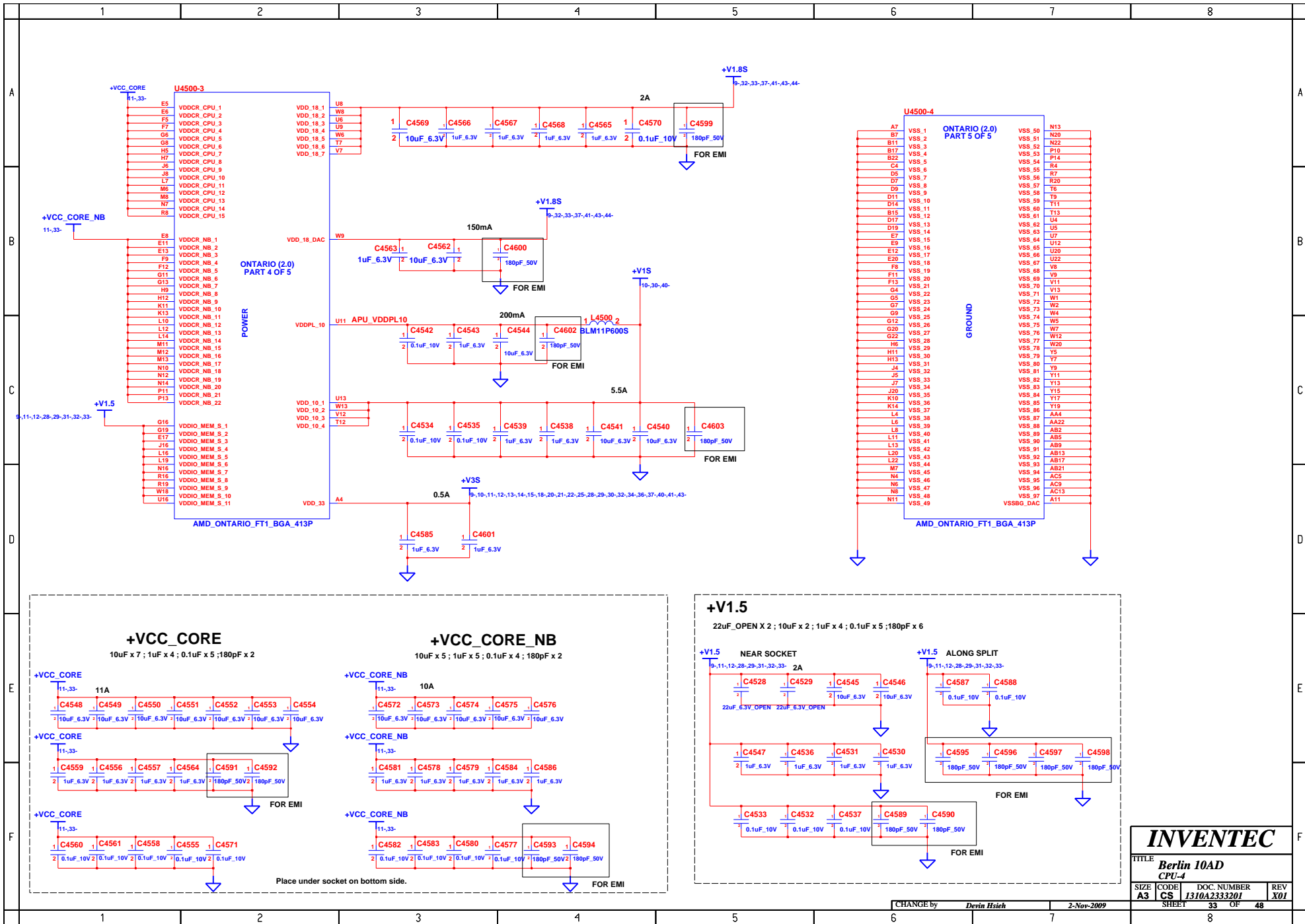

INVENTEC				
TITLE Berlin 10AD CPU-4				
SIZE A3	CODE CS	DOC. NUMBER 1310A2333201	REV X01	
SHEET 33		OF 48		

CHANGE by *Devlin Hsieh* 2-Nov-2009

Place under socket on bottom side.

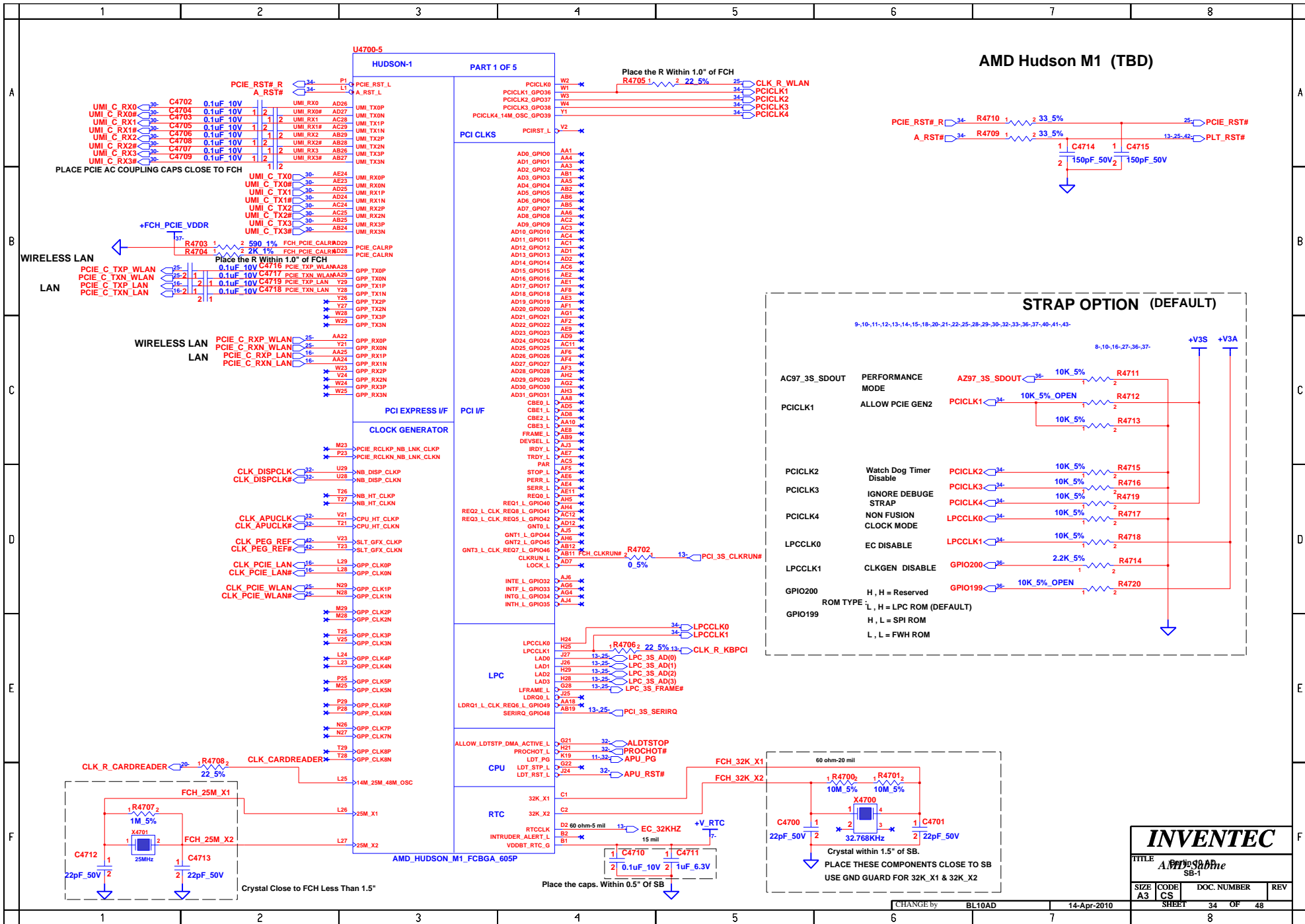

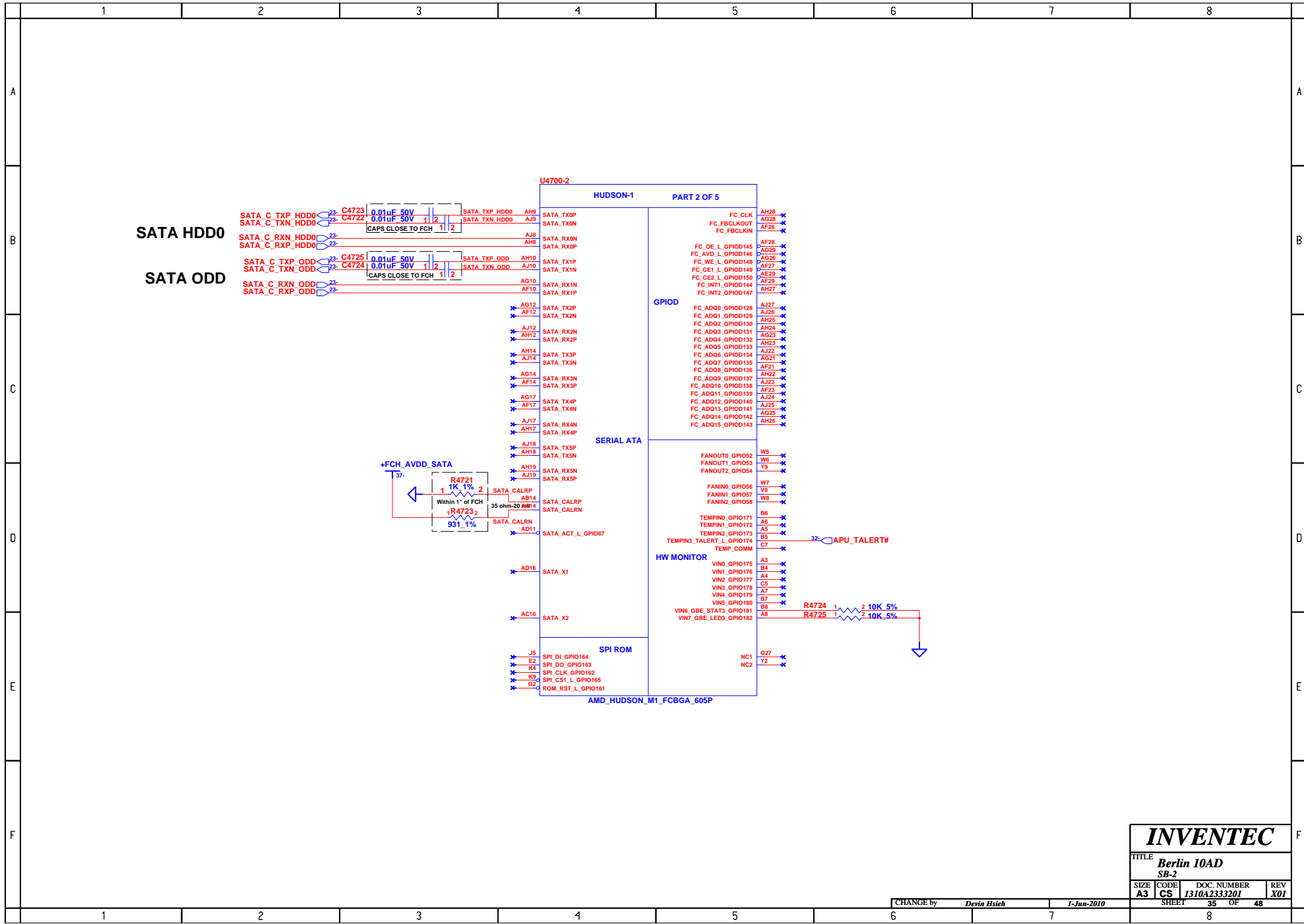

INVENTEC			
TITLE Berlin 10AD			
SB-2			
SIZE A3	CODE CS	DOC. NUMBER 1310A2333201	REV X01
CHANGE by <i>Devin Hsieh</i>		1-Jun-2010	
SHEET		35 OF 48	

EMI

INVENTEC

TITLE			
<i>Berlin 10AD</i>			
<i>EMI</i>			
SIZE	CODE	DOC. NUMBER	REV
A3	CS	<i>1310A2333201</i>	<i>X01</i>
SHEET		38	OF 48

CHANGE by *Devin Hsieh* 5-Jul-2010

POWER BUTTON

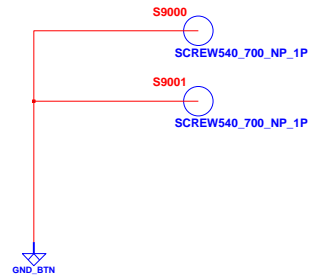
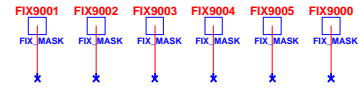
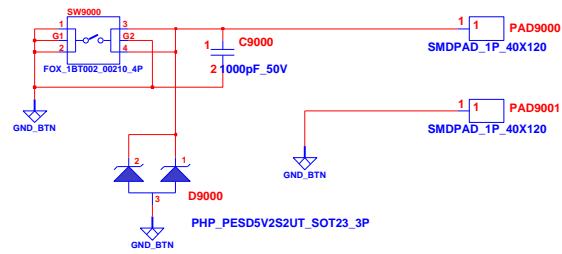

INVENTEC			
TITLE Berlin 10AD Pick Button Board			
SIZE A3	CODE CS	DOC. NUMBER 1310A2333201	REV X01
CHANGE by <i>Devin Hsieh</i>		28-Jul-2010	
SHEET		39	OF 48

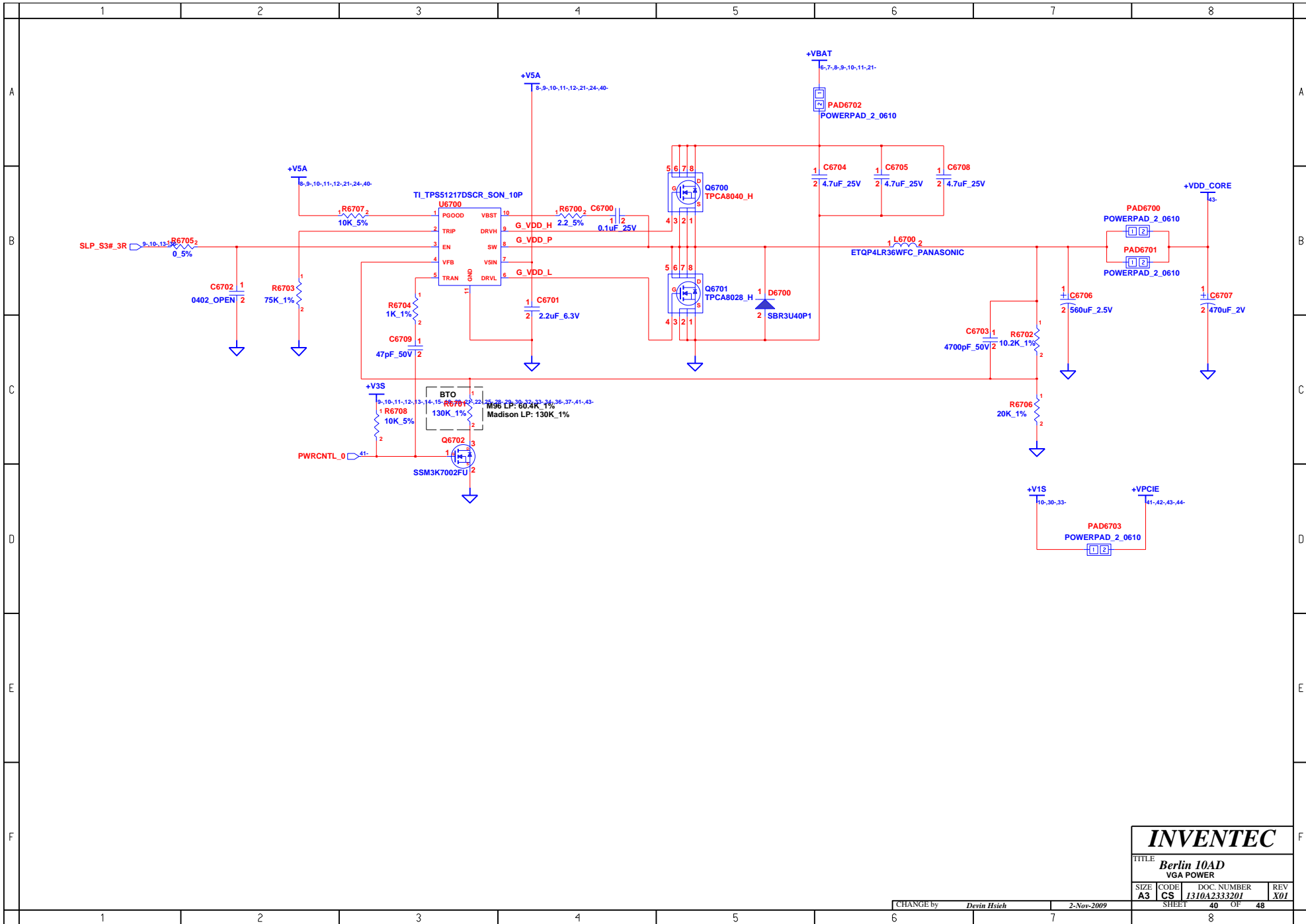

INVENTEC

TITLE
Berlin 10AD
 VGA POWER

SIZE A3	CODE CS	DOC NUMBER 1310A2333201	REV X01
-------------------	-------------------	-----------------------------------	-------------------

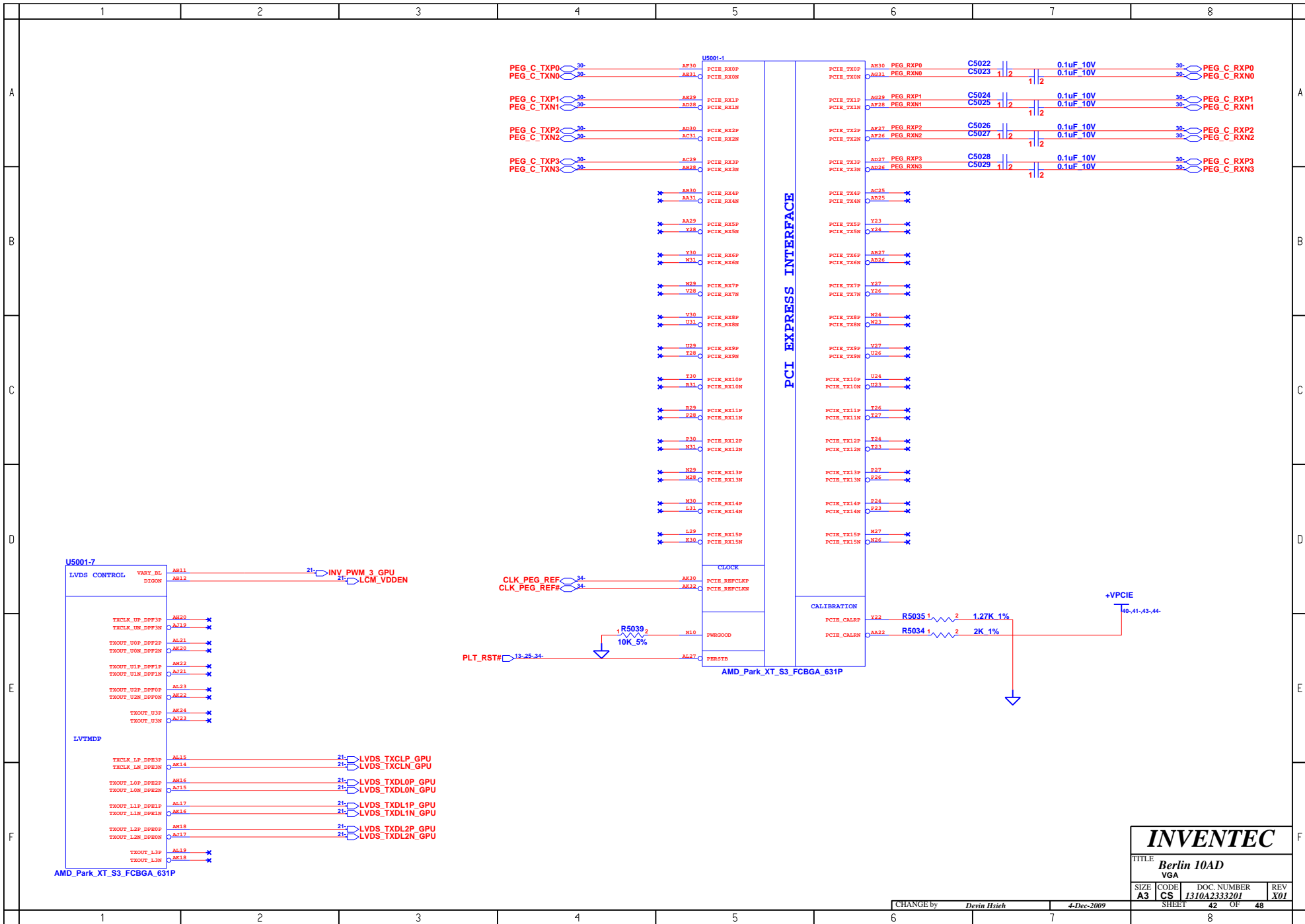

INVENTEC			
TITLE Berlin 10AD			
VGA			
SIZE A3	CODE CS	DOC. NUMBER 1310A2333201	REV X01
CHANGE by <i>Devlin Hsieh</i>		4-Dec-2009	
SHEET 42		OF 48	

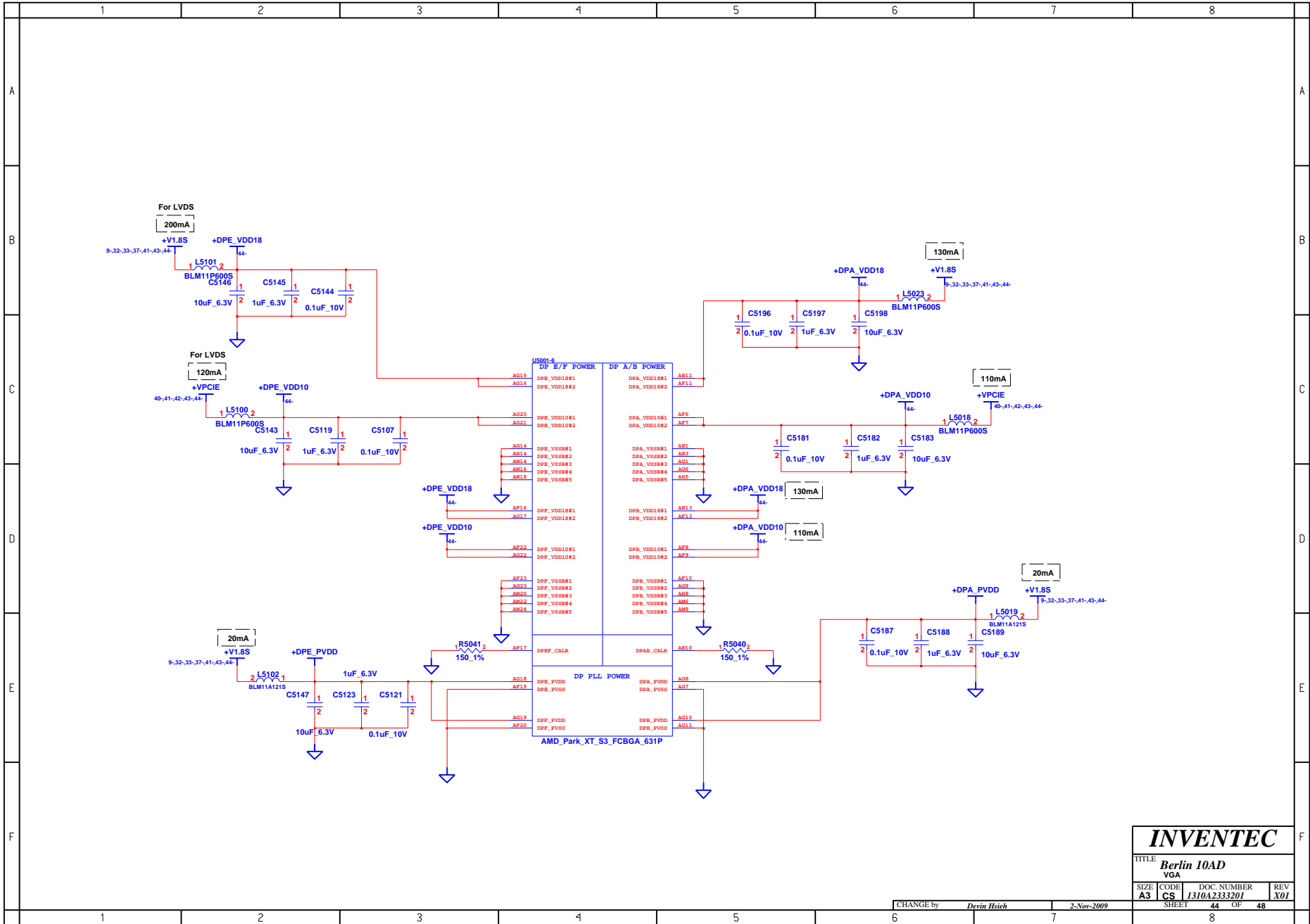

INVENTEC			
TITLE Berlin 10AD			
VGA			
SIZE A3	CODE CS	DOC. NUMBER 1310A2333201	REV X01
CHANGE by <i>Devin Hsieh</i>		2-Nov-2009	SHEET 44 OF 48

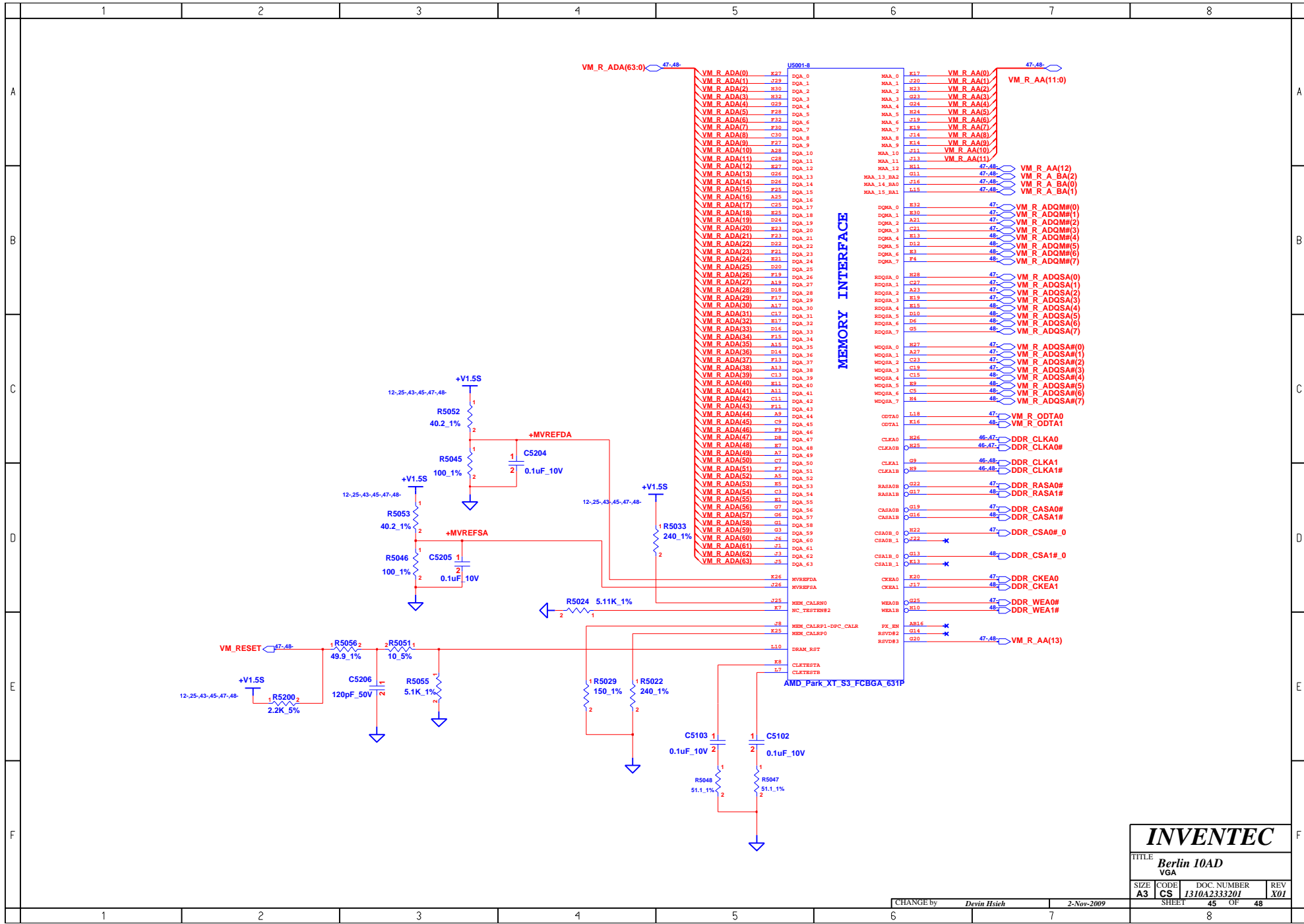

INVENTEC

TITLE **Berlin 10AD**
VGA

SIZE	CODE	DOC. NUMBER	REV
A3	CS	1310A2333201	X01

CHANGE by *Devin Hsieh* 2-Nov-2009

SHEET 45 OF 48

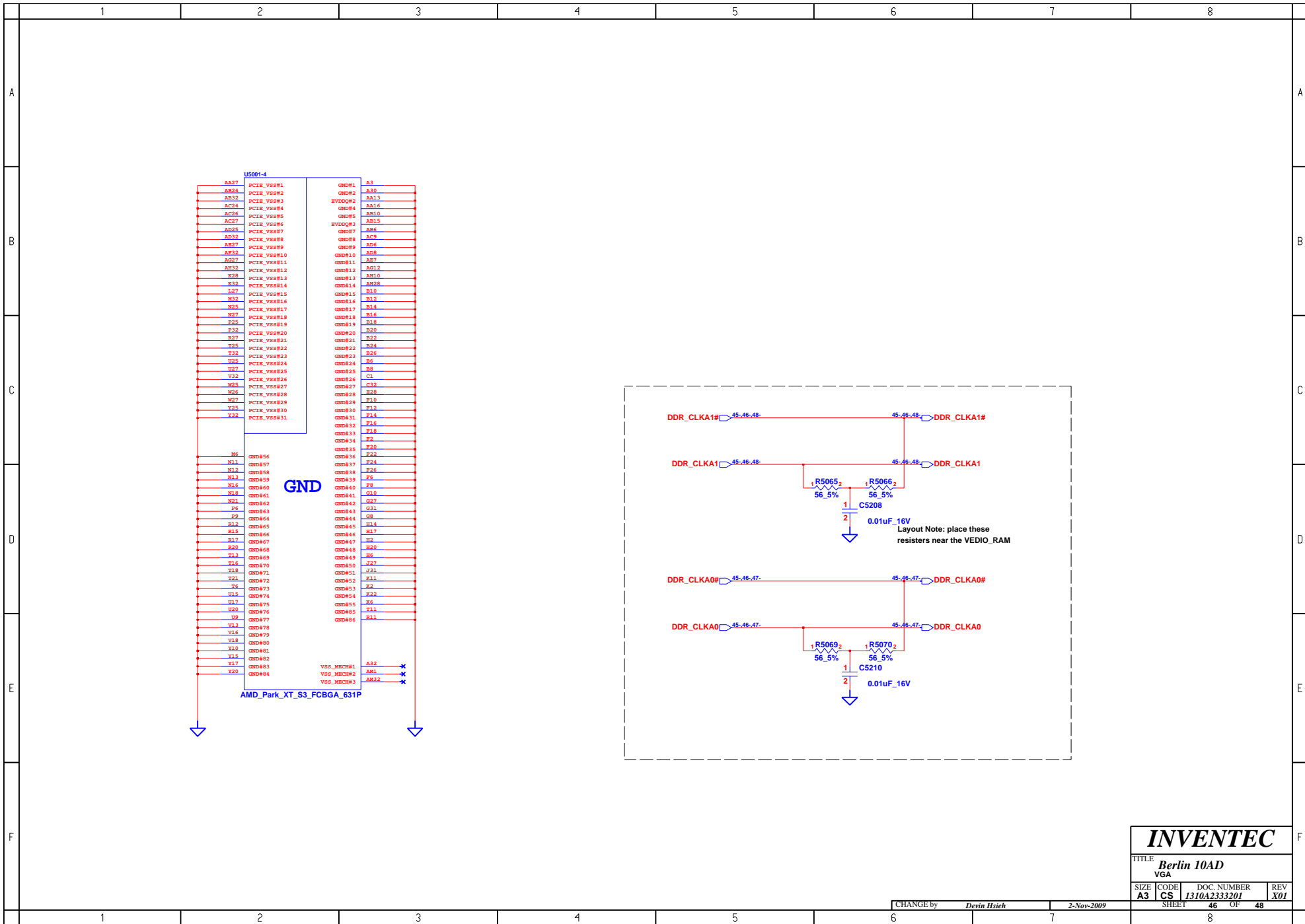

INVENTEC			
TITLE Berlin 10AD			
VGA			
SIZE A3	CODE CS	DOC. NUMBER 1310A2333201	REV X01
CHANGE by <i>Devin Hsieh</i>		2-Nov-2009	
SHEET 46		OF 48	

PARK Use channel A

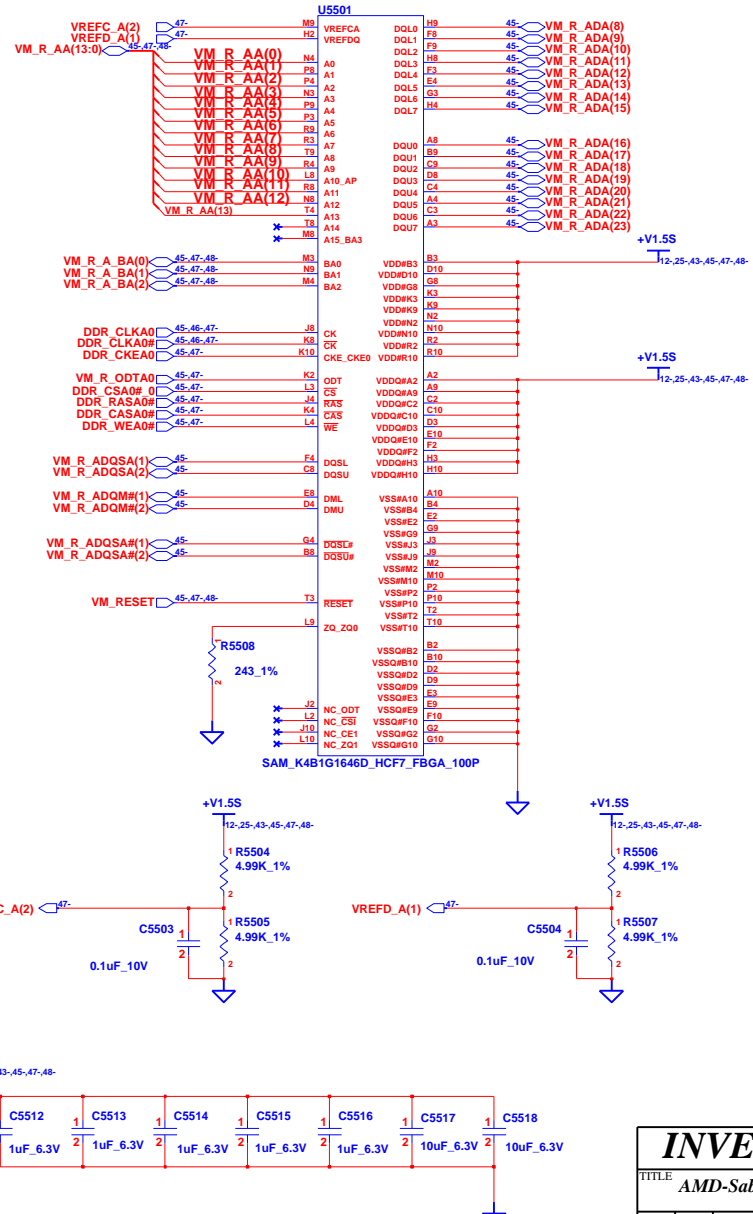
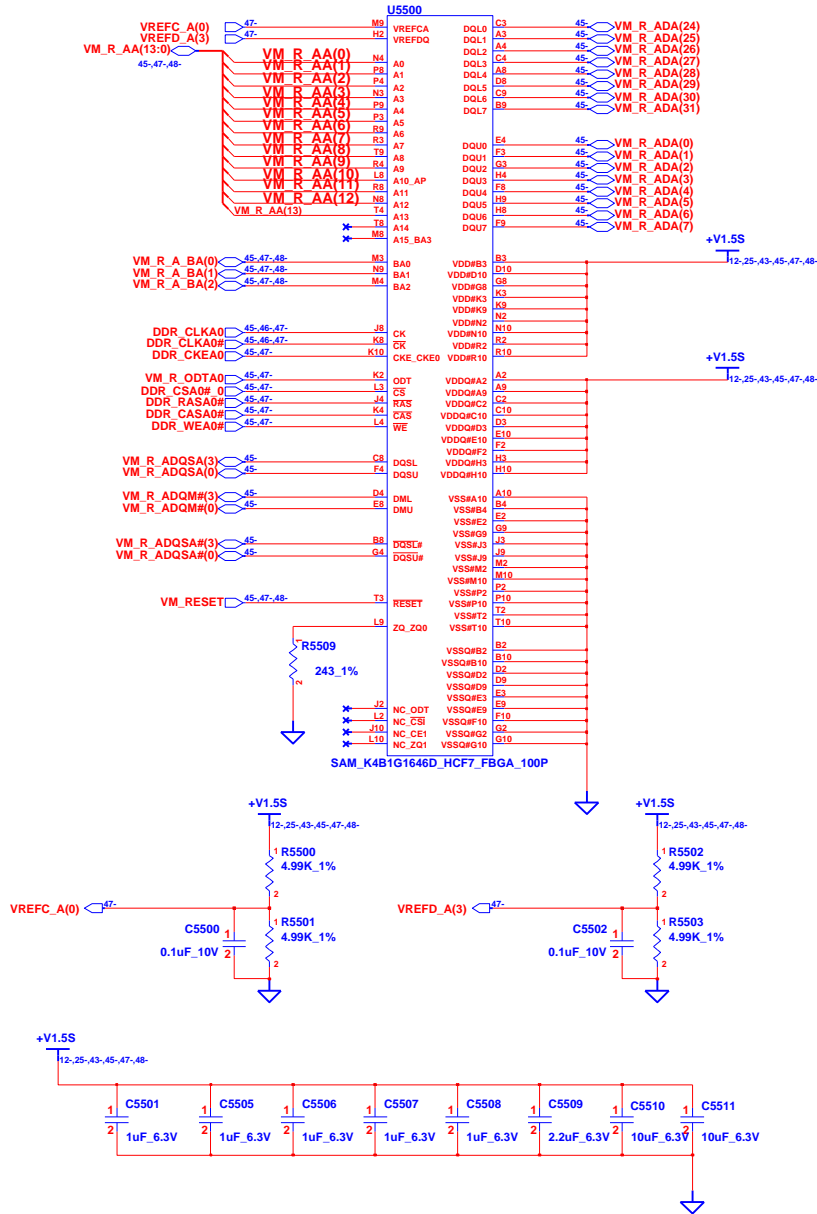

INVENTEC			
TITLE AMD-Sabine			
SIZE A3	CODE CS	DOC. NUMBER	REV
SHEET		47	OF 48

CHANGE by BL10AD 29-Apr-2010

