

Security Classification	LC Future Center Secret Data	
Issued Date	2013/09/07	Deciphered Date
		2014/09/07
THIS SHEET OF ENGINEERING DRAWING IS THE PROPRIETARY PROPERTY OF LC FUTURE CENTER, AND CONTAINS CONFIDENTIAL AND TRADE SECRET INFORMATION. THIS SHEET MAY NOT BE TRANSFERRED FROM THE CUSTODY OF THE COMPETENT DIVISION OF R&D DEPARTMENT EXCEPT AS AUTHORIZED BY LC FUTURE CENTER. NEITHER THIS SHEET NOR THE INFORMATION IT CONTAINS MAY BE USED BY OR DISCLOSED TO ANY THIRD PARTY WITHOUT PRIOR WRITTEN CONSENT OF LC FUTURE CENTER.		

Title		
BLOCK DIAGRAM		
Size	Document Number	Rev
Custom	BE460 NM-A551	1.0
Date:	Monday, August 10, 2015	Sheet 2 of 83

Voltage Rails (O --> Means ON , X --> Means OFF)

Power Plane / State	B+	+1.8VALW	+1.35V	+5VS +3VS +0.675VS +VCC_CORE +VGA_CORE +3VS_VGA +1.8VS_VGA +1.35VS_VGA +1VS_VGA
S0	O	O	O	O
S3	O	O	O	X
S5 S4/AC Only	O	O	X	X
S5 S4 Battery only	O	X	X	X
S5 S4 AC & Battery don't exist	X	X	X	X

STATE	SIGNAL	SLP_A#	SLP_S3#	SLP_S4#	SLP_S5#	EC_ON	SUSP#
S0		HIGH	HIGH	HIGH	HIGH	ON	ON
S3 (Suspend to RAM)		LOW	LOW	HIGH	HIGH	ON	OFF
S4 (Suspend to Disk)		LOW	LOW	LOW	HIGH	ON	OFF
S5 (Soft OFF)		LOW	LOW	LOW	LOW	ON	OFF

USB2 Port

Port	Device
1	On Board
2	On Board
3	SUB/B
4	ONE-Link DOCK
5	Touch Panel
6	BT
7	CMOS
8	FPR
9	X

USB3 Port

Port	Device
1	On Board
2	On Board
3	SUB/B
4	ONE-Link DOCK

PCIe Port

Port	Device
1	X
2	X
3	WLAN
4	LAN
5	X
6	CardReader
7	X
8	X
9	GPU
10	GPU
11	GPU
12	GPU

SATA Port

Port	Device
1	HDD
2	X
3	X
4	X

SMBUS Control Table

SOURCE	Main VGA	BATT	SODIMM	WLAN WIMAX	Thermal Sensor	PCH	CP Module	Security ROM	LAN PHY	G-Sensor
EC_SMB_CLK1 EC_SMB_DA1	IT8580F +3VL	X +3VALW	X	X	X	X	X	X	X	X
EC_SMB_CLK3 EC_SMB_DA3	IT8580F +3VS	X +3VS_VGA	X	X	X	X +3VALW_PCH	X	X	X	X +3VALW
PCH_SMB_CLK PCH_SMB_DATA	PCH +3VALW_PCH	X	X	X +3VS	X	X	X +5VS	X +3VS	X	X
PCH_SML0_CLK PCH_SML0_DAT	PCH +3VALW_PCH	X	X	X	X	X	X	X	X +3VALW	X

LCFC

Security Classification	LC Future Center Secret Data		
Issued Date	2013/09/07	Deciphered Date	2014/09/07
THIS SHEET OF ENGINEERING DRAWING IS THE PROPRIETARY PROPERTY OF LC FUTURE CENTER, AND CONTAINS CONFIDENTIAL AND TRADE SECRET INFORMATION. THIS SHEET MAY NOT BE TRANSFERRED FROM THE CUSTODY OF THE COMPETENT DIVISION OF R&D DEPARTMENT EXCEPT AS AUTHORIZED BY LC FUTURE CENTER NEITHER THIS SHEET NOR THE INFORMATION IT CONTAINS MAY BE USED BY OR DISCLOSED TO ANY THIRD PARTY WITHOUT PRIOR WRITTEN CONSENT OF LC FUTURE CENTER.			

Title	NOTE LIST
Size	Document Number
Custom	BE60-NM-A551
Date	Wednesday, August 05, 2015
Sheet	3 of 83



VGA and DDR3 Voltage Rails (JET TOPAZ GPIO)

GPIO	I/O	ACTIVE	Function Description
GPIO0	OUT	N/A	
GPIO5	IN	-	GPIO5_AC_BATT
GPIO6	IN	-	GPIO6
GPIO7	OUT	N/A	
GPIO8	OUT	-	GPIO8_ROMSO
GPIO9	OUT	-	GPIO9_ROMSI
GPIO10	OUT	-	GPIO10_ROMSCK
GPIO11	OUT	N/A	
GPIO12	OUT	N/A	
GPIO13	OUT	N/A	
GPIO15	IN	N/A	SVI2_SVD
GPIO16	OUT	N/A	
GPIO17	OUT	N/A	
GPIO19	OUT	N/A	GPIO19_CTF
GPIO20	IN	IN	SVI2_SVC
GPIO21	OUT	N/A	
GPIO22	OUT	N/A	GPIO22_ROMCSB
GPIO29	OUT	N/A	
GPIO30	OUT	N/A	

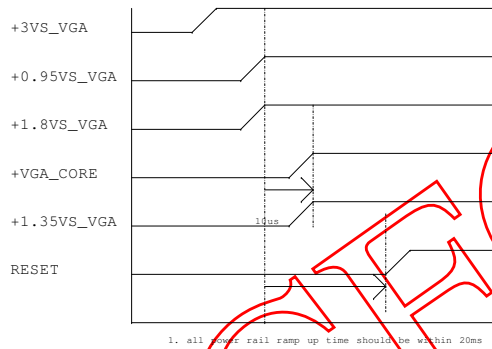

	Device ID
JET-XT	0x6664
TOPAZ XT	0x6900

BOM Structure Table

BOM Structure	NOTE
EXO@	For GPU_EXO
MESO@	For GPU_MESO
DIS@	For GPU function
X76@	GPU VRAM Setting
TPM@	Trusted Platform Module (TPM)
DIMM1@	JDIMM1 function
DIMM2@	JDIMM2 function
UMA@	UMA SKU ID
DPRE@	DP re-driver function
NODPRE@	Disable DP re-driver
MIRROR@	For mirror function
ME@	ME Connector
EMC@	For EMC function
NVPRO@	For Non-VPRO function
VPRO@	For VPRO function
U31@	For U3 port1 redriver function
U32@	For U3 port2 redriver function
U33@	For U3 port3 redriver function
NU3R@	No U3 redriver function (All port)
RF@	For RF function
TS@	For Touch function

		RV104	RV105
Memory (GDDR3)			
Samsung	1G	SA22225SH30*4	PU 8.45K PD 2K
	2G	SA000063F00*4	PU 3.4K PD 10K
Hynix	1G	SA00005VS10*4	PU 4.53K PD 2K
	2G	SA00005YL10*4	PU 4.75K NC
Micron	1G	SA00005M100*4	NC PD 4.75K
	2G	SA000060I00*4	PU 3.24K PD 5.62K

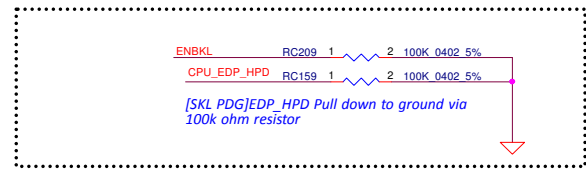
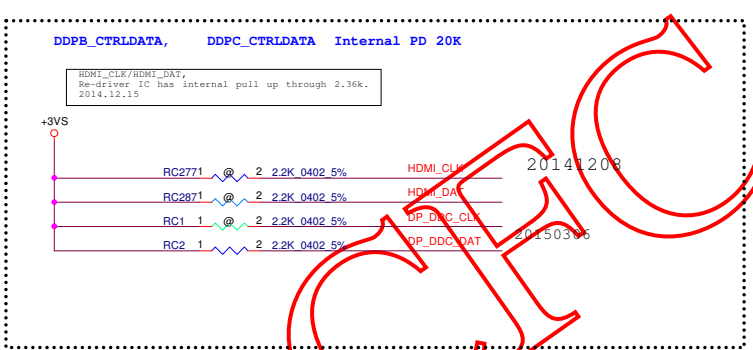
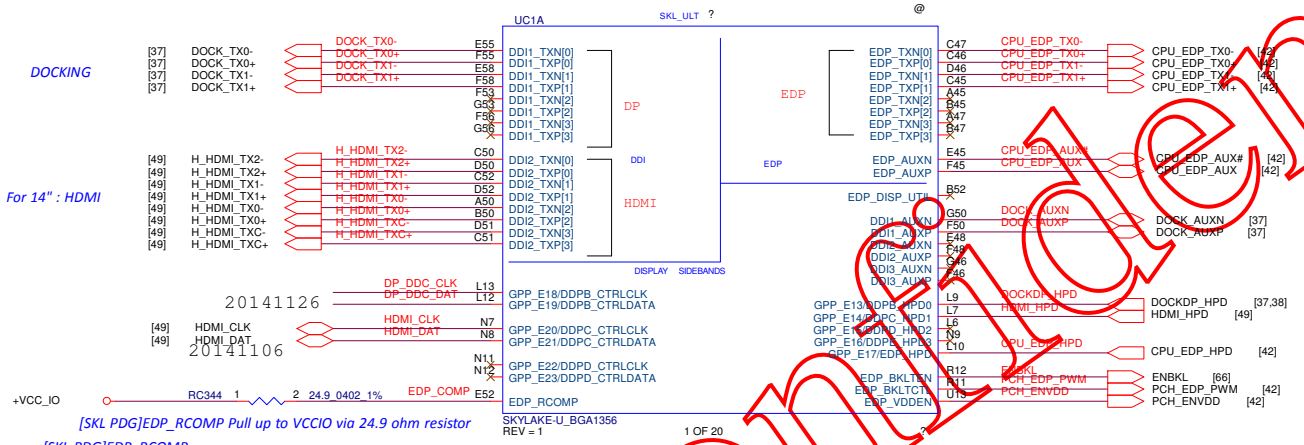



DDPB_CTRLDATA	Port B Detected	This signal has an integrated weak pull-down (20 KΩ nominal) resistor. When this signal is pulled up to VCC3_3 through a 1-3.6 KΩ ±5% resistor at the rising edge of PCH_PPWROK the Digital Display Port B will be detected.
DDPC_CTRLDATA	Port C Detected	This signal has an integrated weak pull-down (20 KΩ nominal) resistor. When this signal is pulled up to VCC3_3 through a 1-3.6 KΩ ±5% resistor at the rising edge of PCH_PPWROK the Digital Display Port C will be detected.

Security Classification	LC Future Center Secret Data	
Issued Date	2014/05/07	Deciphered Date 2015/05/07
THIS SHEET OF ENGINEERING DRAWING IS THE PROPRIETARY PROPERTY OF LC FUTURE CENTER, AND CONTAINS CONFIDENTIAL AND TRADE SECRET INFORMATION. THIS SHEET MAY NOT BE TRANSFERRED FROM THE CUSTODY OF THE COMPETENT DIVISION OF R&D DEPARTMENT EXCEPT AS AUTHORIZED BY LC FUTURE CENTER NEITHER THIS SHEET NOR THE INFORMATION IT CONTAINS MAY BE USED BY OR DISCLOSED TO ANY THIRD PARTY WITHOUT PRIOR WRITTEN CONSENT OF LC FUTURE CENTER.		

Title	SKL(1/16):DDI/EDP	
Size	Document Number	Rev
Custom	BB460_NW-A551	1.0
Date:	Wednesday, August 05, 2015	Sheet 5 of 83

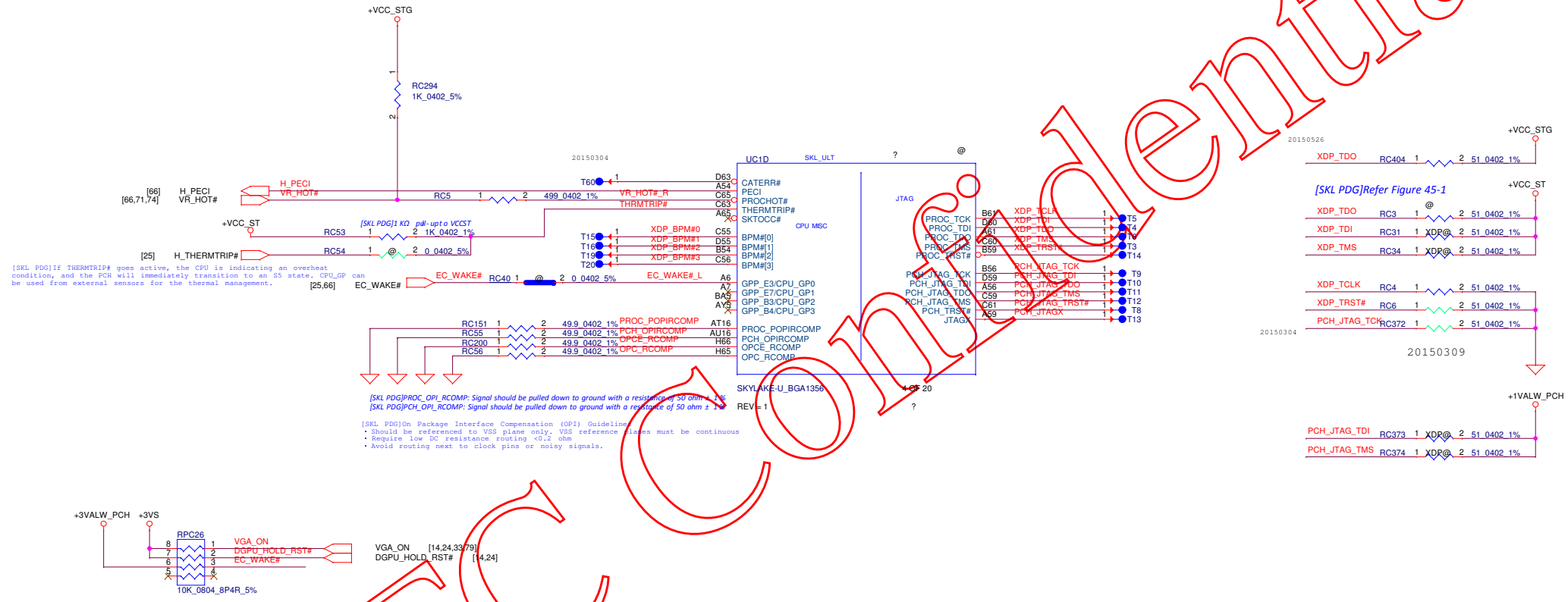
CONFIDENTIAL



Security Classification		LC Future Center Secret Data		Title		
Issued Date	2014/05/07	Deciphered Date	2015/05/07	SKL(2/16):MISC/JTAG		
THIS SHEET OF ENGINEERING DRAWING IS THE PROPRIETARY PROPERTY OF LC FUTURE CENTER, AND CONTAINS CONFIDENTIAL AND TRADE SECRET INFORMATION. THIS SHEET MAY NOT BE TRANSFERRED FROM THE CUSTODY OF THE COMPETENT DIVISION OF R&D DEPARTMENT EXCEPT AS AUTHORIZED BY LC FUTURE CENTER NEITHER THIS SHEET NOR THE INFORMATION IT CONTAINS MAY BE USED BY OR DISCLOSED TO ANY THIRD PARTY WITHOUT PRIOR WRITTEN CONSENT OF LC FUTURE CENTER.						
Size	Document	Number	Rev			
Custom	BB460_NW-A551		1.0			
Date:	Wednesday, August 05, 2015		Sheet	6	of	83

[22] DDR_A_D[0..63]
 [22] DDR_A_DQS#[0..7]
 [22] DDR_A_DQS#[0..7]
 [22] DDR_A_MA[0..15]



20141201

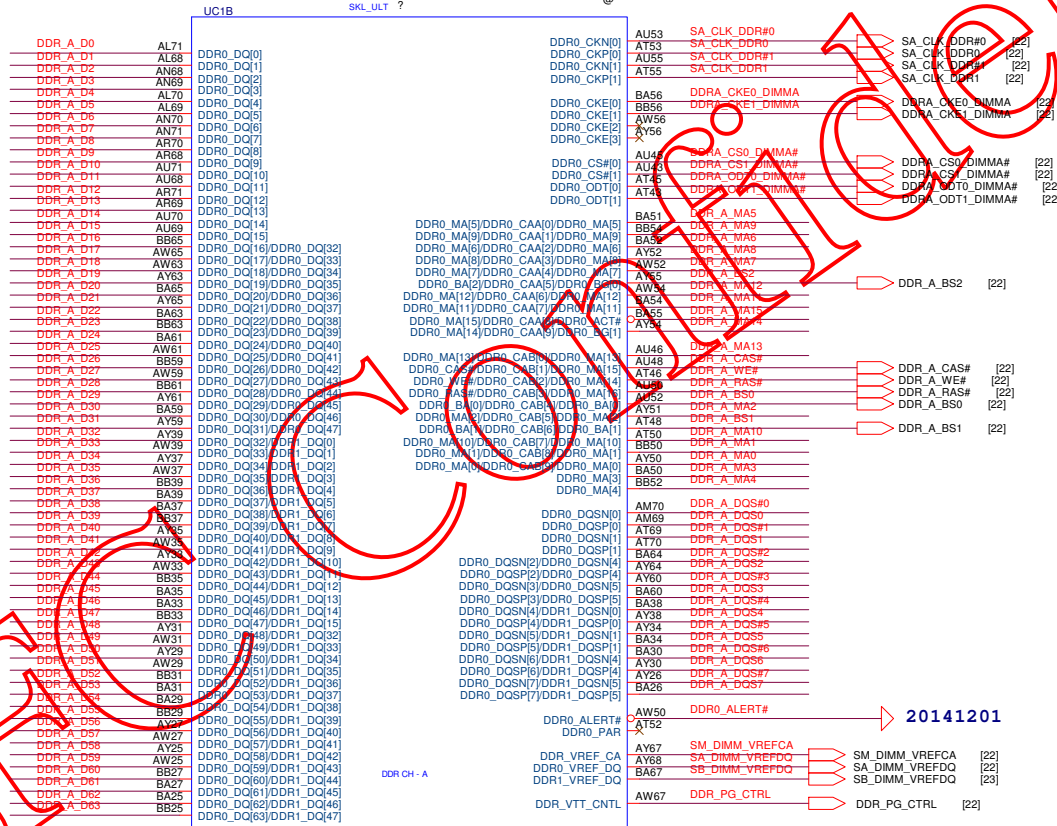
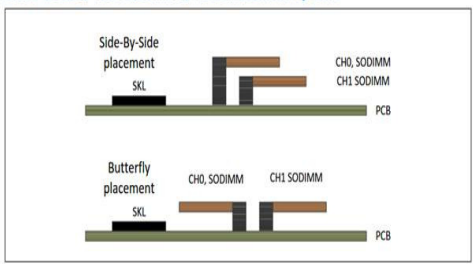

Figure 4-14. SKL U DDR3L/-RS SODIMM T3/8L IL Placement Options



Security Classification		LC Future Center Secret Data	
Issued Date	2014/05/07	Deciphered Date	2015/05/07
THIS SHEET OF ENGINEERING DRAWING IS THE PROPRIETARY PROPERTY OF LC FUTURE CENTER, AND CONTAINS CONFIDENTIAL AND TRADE SECRET INFORMATION. THIS SHEET MAY NOT BE TRANSFERRED FROM THE CUSTODY OF THE COMPETENT DIVISION OF R&D DEPARTMENT EXCEPT AS AUTHORIZED BY LC FUTURE CENTER NEITHER THIS SHEET NOR THE INFORMATION IT CONTAINS MAY BE USED BY OR DISCLOSED TO ANY THIRD PARTY WITHOUT PRIOR WRITTEN CONSENT OF LC FUTURE CENTER.			

Title		
SKL(3/16):DDR3L CH.A		
Size	Document Number	Rev
Custom	BB460_NW-A551	1.0
Date:	Wednesday, August 05, 2015	Sheet 7 of 83

Confidential

[23] DDR_B_D[0..63]
 [23] DDR_B_DQS#[0..7]
 [23] DDR_B_DQS[0..7]
 [23] DDR_B_MA[0..15]



SKYLAKE-U_BGA1356
 REV = 1
 3 OF 20

[SKL PDG]for DDR3L
 DDR_RCOMP[0] Pull down 121 ohm resistor
 DDR_RCOMP[1] Pull down 80.6 ohm resistor
 DDR_RCOMP[2] Pull down 100 ohm resistor

[SKL PDG]DDR_RCOMP
 1. Trace width=12~15 mils, Spacing=20mil, Max length=500mils
 2. R close to MCP

CONFIDENTIAL

Security Classification				LC Future Center Secret Data		Title	
Issued Date	2014/05/07	Deciphered Date	2015/05/07	SKL(4/16):DDR3L CH.B			
THIS SHEET OF ENGINEERING DRAWING IS THE PROPRIETARY PROPERTY OF LC FUTURE CENTER, AND CONTAINS CONFIDENTIAL AND TRADE SECRET INFORMATION. THIS SHEET MAY NOT BE TRANSFERRED FROM THE CUSTODY OF THE COMPETENT DIVISION OF R&D DEPARTMENT EXCEPT AS AUTHORIZED BY LC FUTURE CENTER NEITHER THIS SHEET NOR THE INFORMATION IT CONTAINS MAY BE DISCLOSED TO ANY THIRD PARTY WITHOUT PRIOR WRITTEN CONSENT OF LC FUTURE CENTER.							
Size	Document	Number	Rev	LCFC			
Custom		BB460_NW-A551	1.0				
Date:	Wednesday, August 05, 2015	Sheet	8	of 83			

[SKL PDG] Manufacturing Mode Jumper

1. If strap is sampled low, the security measures defined in the flash descriptor will be in effect (default)
2. If sampled high, the Flash Descriptor Security will be overridden.

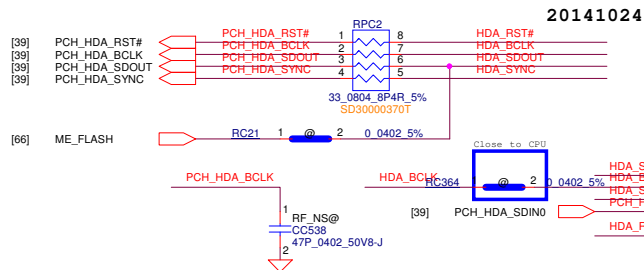

GPP_B14, Internal PD 20K
 No Reboot on TCO
 Timer expiration
 pull-up to VCC3_3 through a 1- 8.2 KΩ ± % resistor to disable this capability

20141202

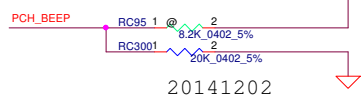

Processor Strapping
 543016_543016_SKL_PDG_UY_1_0_pub
 P780

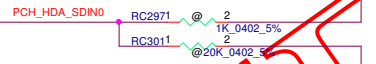

20141202



20141202

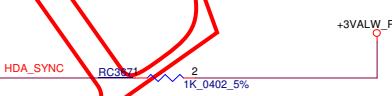

20141106

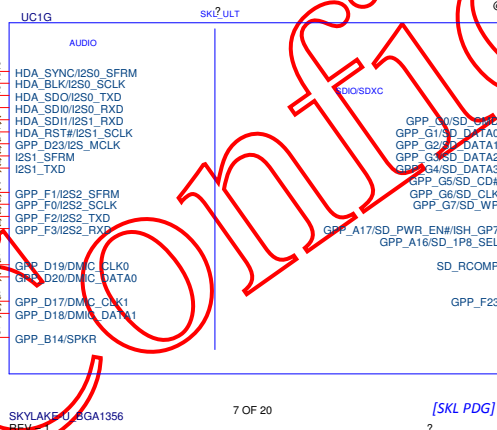
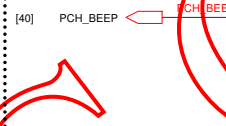

[SKL PDG] internal SD Card

20141106



Security Classification		LC Future Center Secret Data		Title	
Issued Date	2014/05/07	Deciphered Date	2015/05/07	SKL(5/16):HDA/SDIO	
THIS SHEET OF ENGINEERING DRAWING IS THE PROPRIETARY PROPERTY OF LC FUTURE CENTER, AND CONTAINS CONFIDENTIAL AND TRADE SECRET INFORMATION. THIS SHEET MAY NOT BE TRANSFERRED FROM THE CUSTODY OF THE COMPETENT DIVISION OF R&D DEPARTMENT EXCEPT AS AUTHORIZED BY LC FUTURE CENTER NEITHER THIS SHEET NOR THE INFORMATION IT CONTAINS MAY BE USED BY OR DISCLOSED TO ANY THIRD PARTY WITHOUT PRIOR WRITTEN CONSENT OF LC FUTURE CENTER.					
Size	Document Number	Rev		1.0	
Custom	BB460-NM-A551				
Date:	Wednesday, August 05, 2015	Sheet	9	of	83

Confidential

TOP SECRET

RTC External Circuit

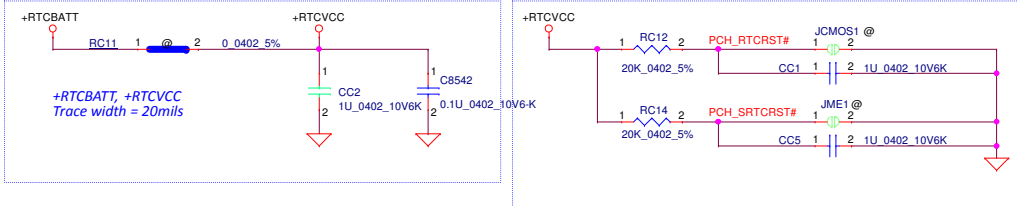

[SKL PDG] used to set BIAS reference for differential clocks. Connect to a 2.7k ± 0.5% precision resistor to 1.0v.

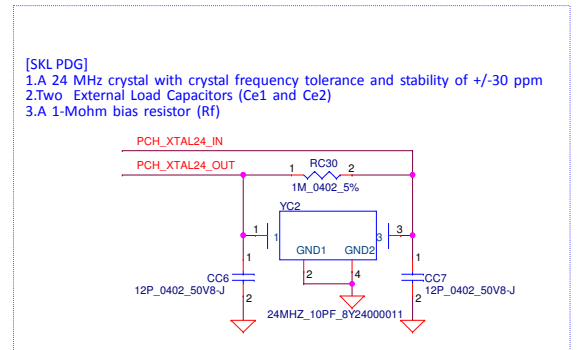
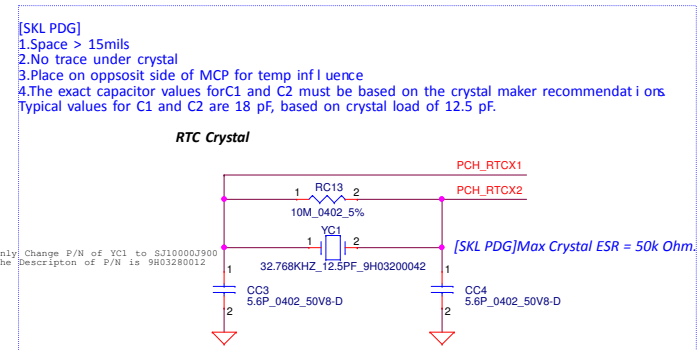

LOFC

Security Classification				LC Future Center Secret Data				Title		
Issued Date	2014/05/07	Deciphered Date	2015/05/07	SKL(6/16):CLOCK SIGNALS				LCFC		
THIS SHEET OF ENGINEERING DRAWING IS THE PROPRIETARY PROPERTY OF LC FUTURE CENTER, AND CONTAINS CONFIDENTIAL AND TRADE SECRET INFORMATION. THIS SHEET MAY NOT BE TRANSFERRED FROM THE CUSTODY OF THE COMPETENT DIVISION OF R&D DEPARTMENT EXCEPT AS AUTHORIZED BY LC FUTURE CENTER NEITHER THIS SHEET NOR THE INFORMATION IT CONTAINS MAY BE USED BY OR DISCLOSED TO ANY THIRD PARTY WITHOUT PRIOR WRITTEN CONSENT OF LC FUTURE CENTER.								Size	Document Number	Rev
								Custom	BB460_NW-A551	1.0
								Date:	Wednesday, August 05, 2015	Sheet 10 of 83

Functional Strap Definitions

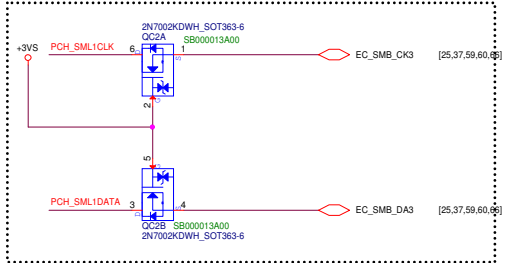
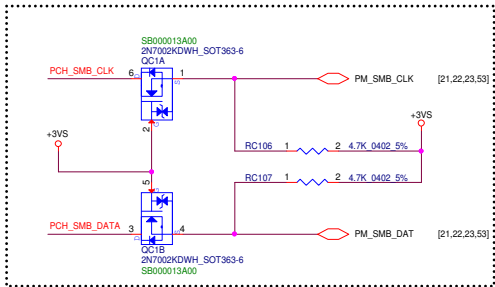
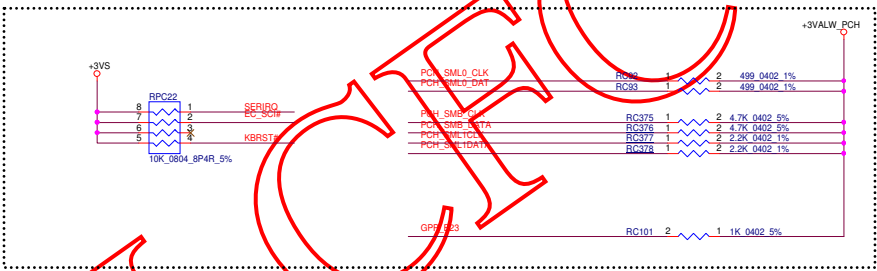
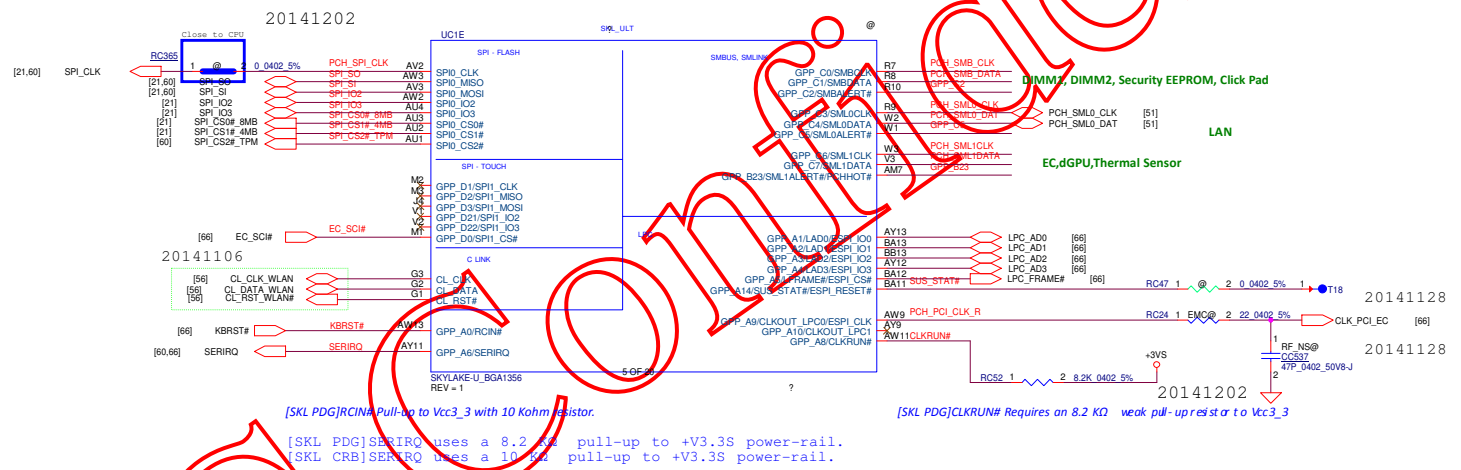
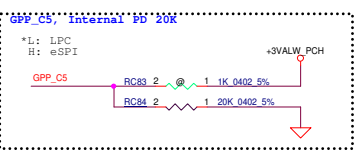
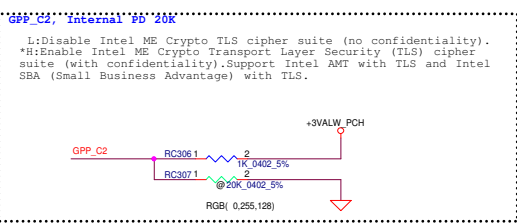
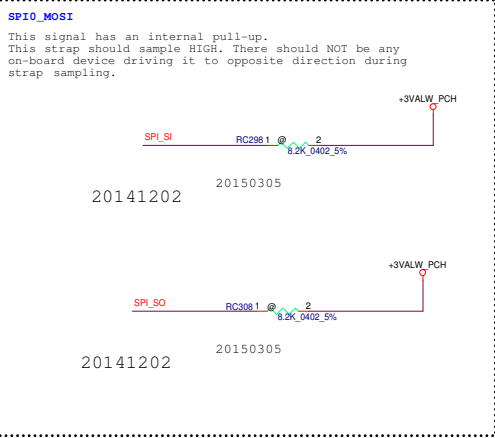

[SKL PDG]SYS_RESET#: Connect this signal on PCH directly to the reset button and pull-up its signal to +V3 3V core rail through a weak pull-up resistor (8.2~10 Kohm).

[SKL PDG]PROCPWRGD
 1. Indicates that VCCIN, VDDQ power supplies and clocks are stable. This signal will be asserted only after PCH_PWRGD assertion.
 2. PROCPWRGD is used only for power sequence debug and is not required to be connected to anything on the platform.

[SKL PDG]SLP_S3, SLP_S4, SLP_S5: No pull-up/pull-down resistors needed. Signals driven by the PCH.

[SKL PDG]SLP_A: No pull-up/pull-down resistors needed. Signals driven by the PCH. Can be left as NC when the active management technology (INTR_A) is not supported on the platform. When asserted (INTR_A), it is not supported on the platform.

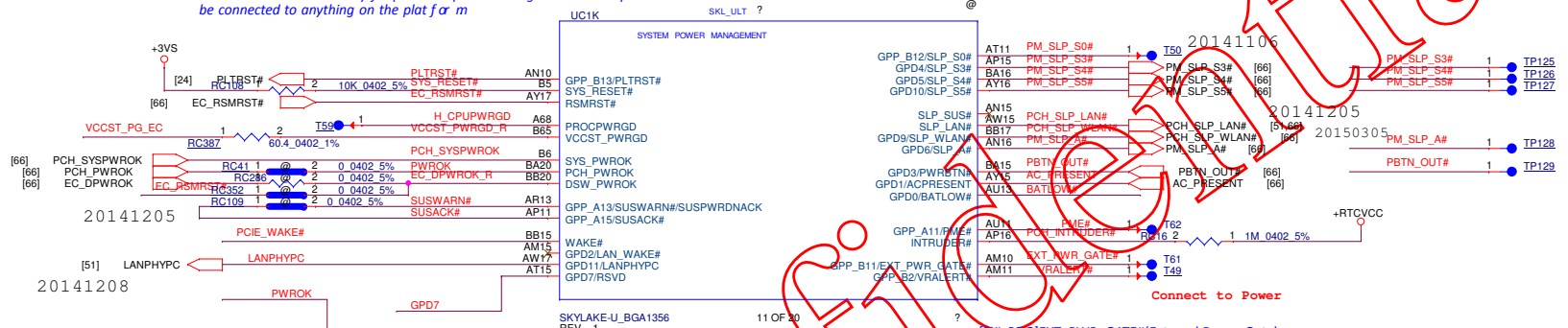

[SKL PDG]AC_PRESENT#: 8.2~10 KΩ pull-up to DS Wvdl.

[SKL PDG]BATLOW#: 8.2~10 KΩ pull-up to DS Wvdl.

[SKL PDG]WAKE#: 10 KΩ pull-up to Vc DS VB_3

[SKL PDG]APWROK: There is no corresponding APWROK signal input to the PCH, but the PCH does have an internally generated version of APWROK that is tied to mSLP_A#

[SKL PDG]EXT_PWR_GATE#(External Power Gate)
 1. HSIO Power Control: Used to control power to VCCMPHYGT_1p0, VCCMPHYPLL_1p0 and VCCSRAM_1p0 in S0 & Sx.
 2. PCH will drive EXT_PWR_GATE# low when all the high speed IO controllers (xHC, SATA and PCIe) are idle or have no devices attached.

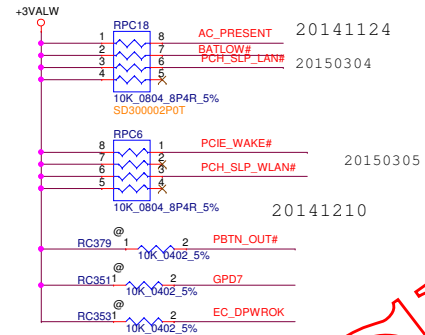

[SKL PDG]RSMRST#: Recommend an 8.2~10 Kohm pull-down resistor to ground. Note: CRB uses 10 KΩ pull-down

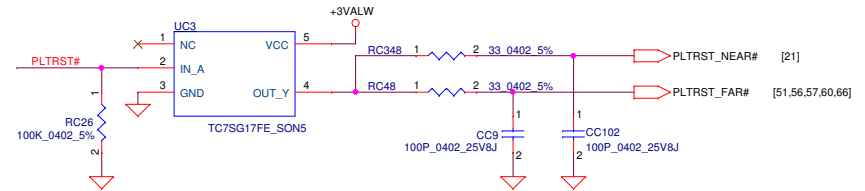
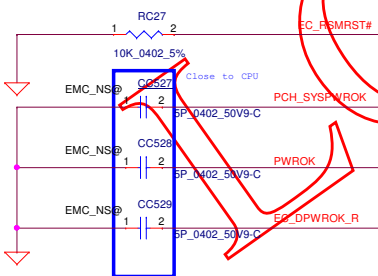

Security Classification				LC Future Center Secret Data		Title	
Issued Date	2014/05/07	Deciphered Date	2015/05/07	SKL(8/16):SYSTEM PM			
THIS SHEET OF ENGINEERING DRAWING IS THE PROPRIETARY PROPERTY OF LC FUTURE CENTER, AND CONTAINS CONFIDENTIAL AND TRADE SECRET INFORMATION. THIS SHEET MAY NOT BE TRANSFERRED FROM THE CUSTODY OF THE COMPETENT DIVISION OF R&D DEPARTMENT EXCEPT AS AUTHORIZED BY LC FUTURE CENTER. NEITHER THIS SHEET NOR THE INFORMATION IT CONTAINS MAY BE USED BY OR DISCLOSED TO ANY THIRD PARTY WITHOUT PRIOR WRITTEN CONSENT OF LC FUTURE CENTER.							
Size	Document Number	Rev		BBA60-NM-A551 Date: Wednesday, August 05, 2015 Sheet 12 of 83			

+VCC_CORE [SKL PDG]VCC
[SKL PDG] 10uF x 3, 1uF x 34.

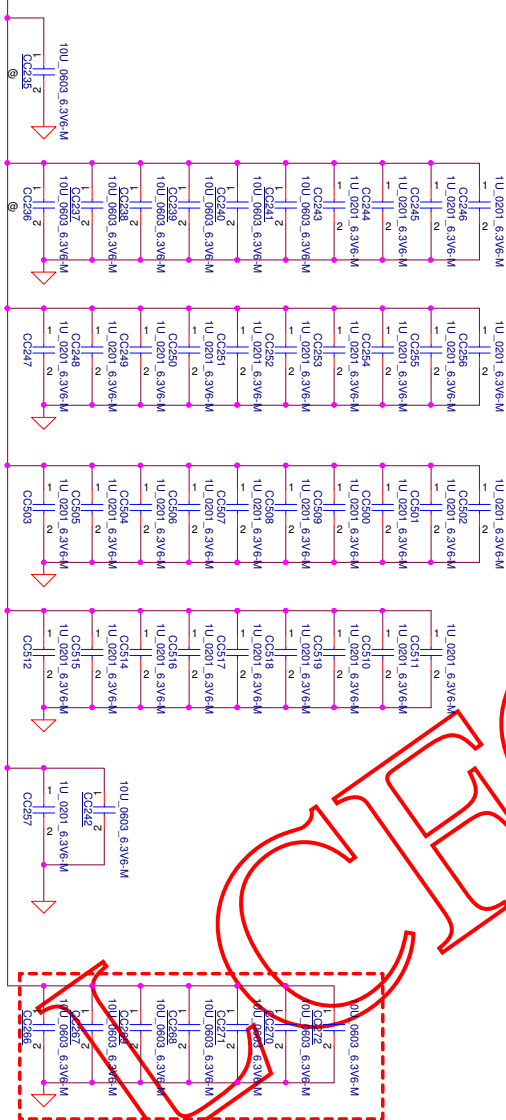

+VCC_GT [SKL PDG]VCCGT
[SKL PDG] 10uF x 4, 1uF x 16

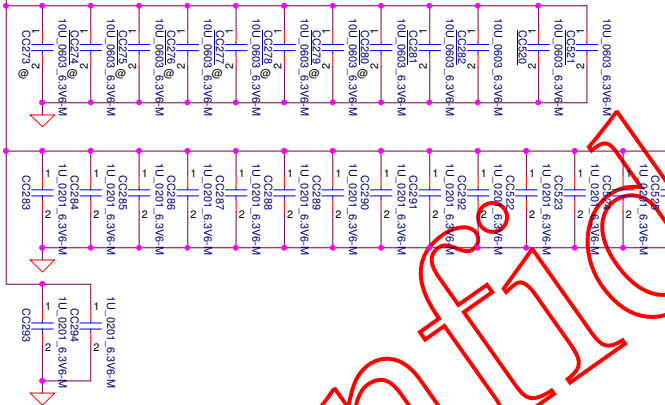

20141126

CONFIDENTIAL

Security Classification		LC Future Center Secret Data	
Issued Date	2014/05/07	Deciphered Date	2015/05/07
THIS SHEET OF ENGINEERING DRAWING IS THE PROPRIETARY PROPERTY OF LC FUTURE CENTER, AND CONTAINS CONFIDENTIAL AND TRADE SECRET INFORMATION. THIS SHEET MAY NOT BE TRANSFERRED FROM THE CUSTODY OF THE COMPETENT DIVISION OF R&D DEPARTMENT EXCEPT AS AUTHORIZED BY LC FUTURE CENTER NEITHER THIS SHEET NOR THE INFORMATION IT CONTAINS MAY BE USED BY OR DISCLOSED TO ANY THIRD PARTY WITHOUT PRIOR WRITTEN CONSENT OF LC FUTURE CENTER.			

Title		
SKL(9/16):Decoupling		
Size	Document Number	Rev
Custom	BB460_NW-A551	1.0
Date:	Wednesday, August 05, 2015	Sheet 13 of 83

CONFIDENTIAL

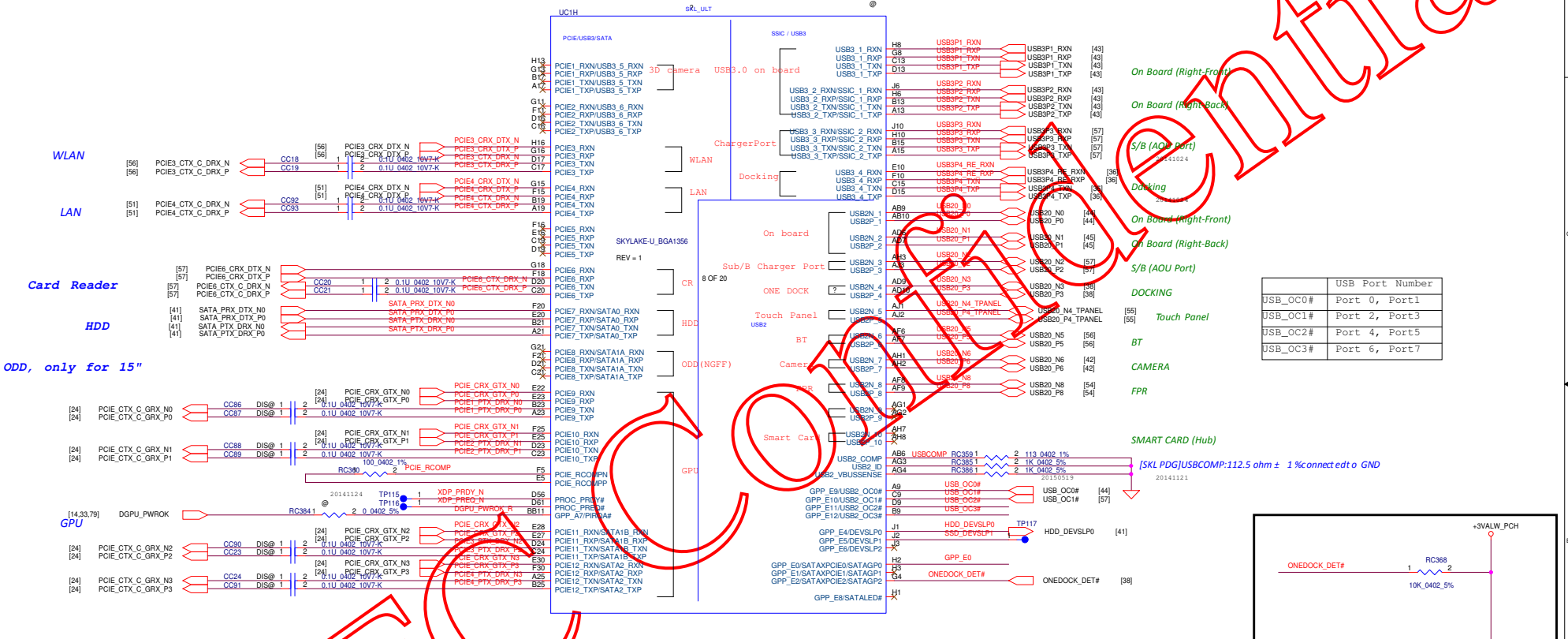

USB Port Number	USB Port Number
USB_OC0#	Port 0, Port1
USB_OC1#	Port 2, Port3
USB_OC2#	Port 4, Port5
USB_OC3#	Port 6, Port7

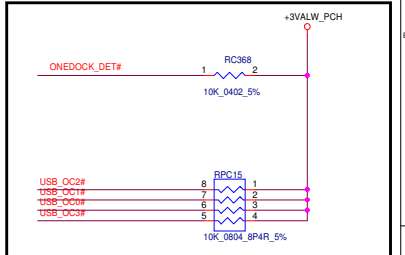

[SKL PDG]PCIE_RCOMP
 1.100 ohm +/-0.1% external resistor between RCOMP/RCOMPN

2.SATA compensation circuit is code share with
 PCIE_RCOMP/N different id pin. Refer to RD Express
 Design Guidelines chapter for PCIE_RCOMP/N guideline.

3.Width:12~15Mil
 Space:>12Mil
 Length:Both RCOMP & RCOMPN need to matched to less than 1% trace and board

[SKL PDG] OC [x] pins require a pull-up to VccSus3_3 with 8.2~10 Kohm resistors

[SKL PCH EDs]no external pull-up or pull-down termination required when used as DEVSLP

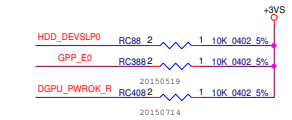

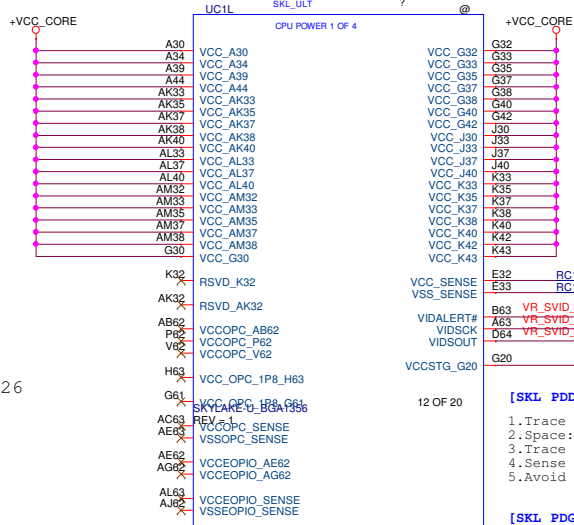

20141126

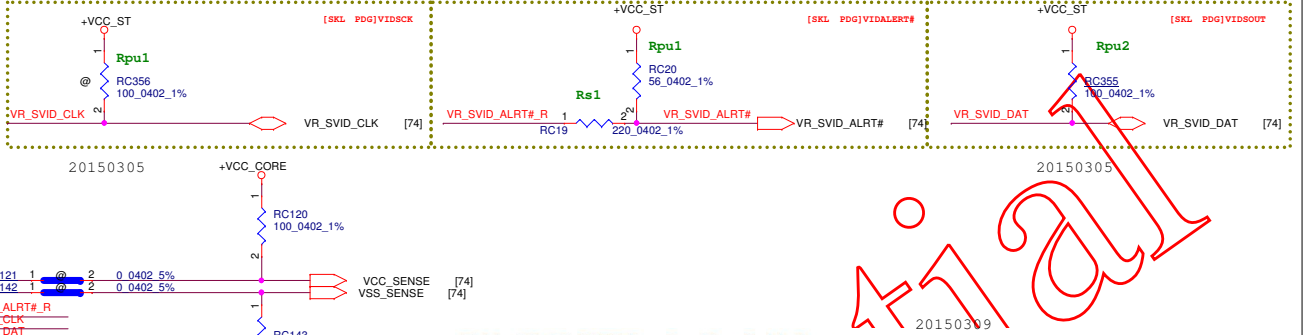

Table 10-10. SVID Bus Routing Guidelines

Signal	W1 [inches]	W2 [inches]	W3/4/5 [inches]	W2+W3+W4+W5 [inches]	W51 [inches]	W52 [inches]	Rpu1 [Ω]	Rpu2 [Ω]	Rps1 [Ω]	Rps2 [Ω]	VCCST [V]
VIDSOUT							100	100	0	10	
VIDSCK	0.5-3	1-15	0.5-4	3-17	<0.1	<0.1	Empty	45	0	50	1.0
VIDALERT #							56	Empty	y	220	0

[SKL PDDG]Package Sensing Recommendations

- Trace Length Match: <25mil
- Space: >25mil
- Trace impedance: 50ohm
- Sense traces should be referenced to a solid ground plane
- Avoid crossing over plane splits

[SKL PDG]SVID

- Alert signal must be routed between Clk and Data signals to minimize Cross-Talk.

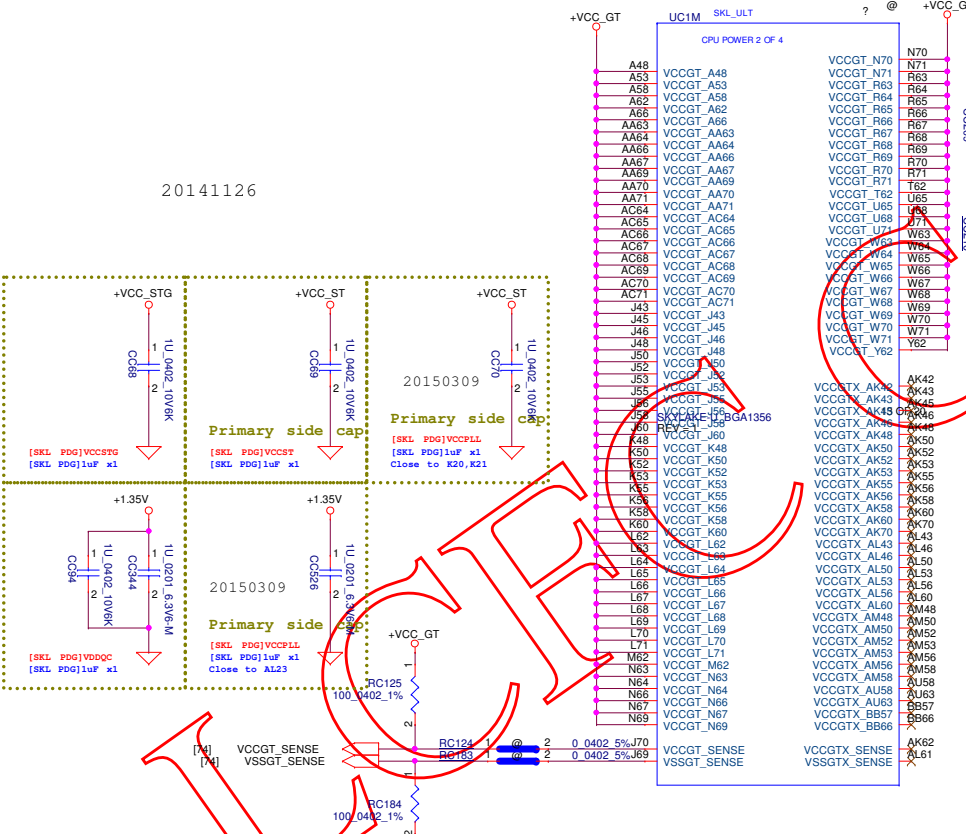

20141126

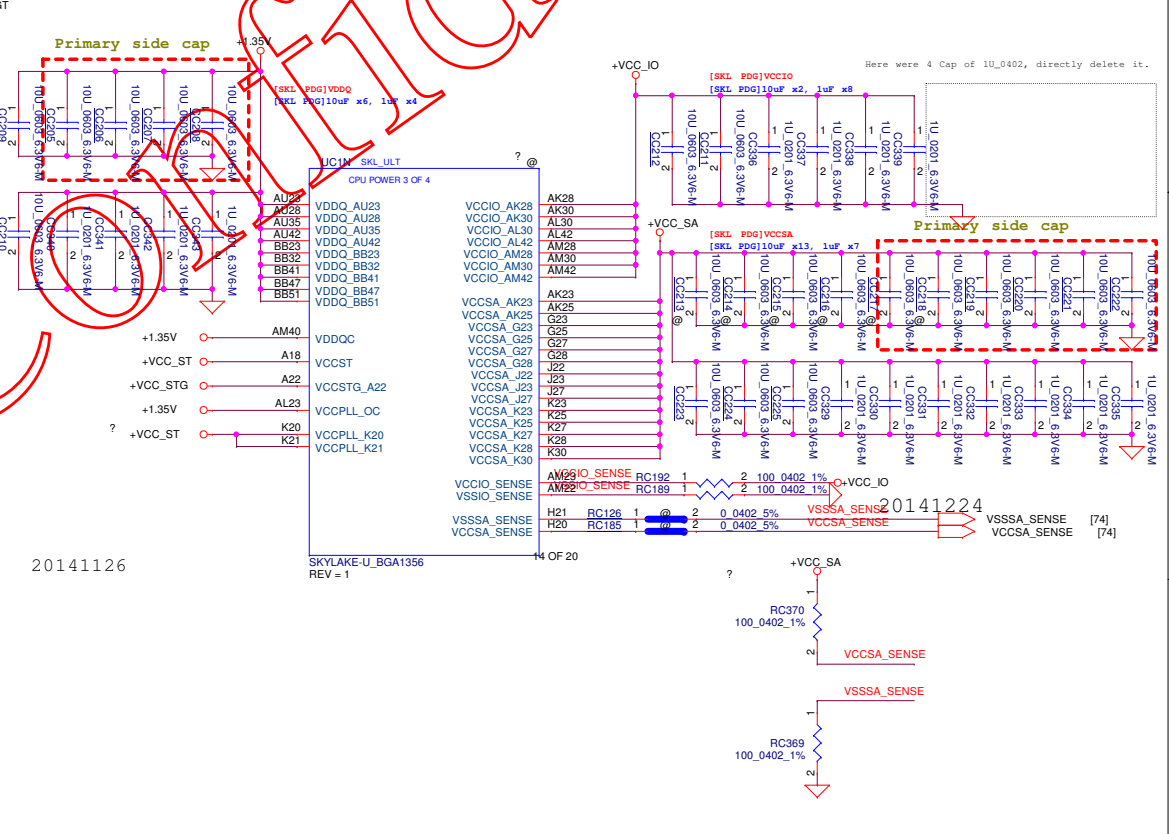

20141126

20150309
(Test point change to 12mil)

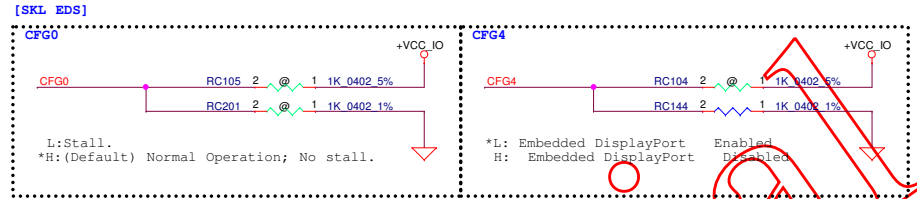

TABLE

CFG0 : Stall Reset Sequence after PCU PLL Lock until de-asserted
1 : No Stall
0 : Stall
CFG4 : eDP Enable
1 : Disabled
0 : Enabled
CFG9 : SVID Bus Communication
1 : Enabled
0 : Disabled

[SKL EDS]Zero Voltage Mode:VCCOCP is fixed OPC VR output voltage of 1V, the processor can drive VR to LPM (Low Power Mode) which sets VR output to 0V using ZVM# signal as shown below:

ZVM# state	VCCOCP
0V	0V
1V	1V

[SKL EDS]Minimum Speed Mode: VCCEOPIO can be connected to OPC VR in this case VCCEOPIO is fixed to 1V. The processor can drive VR to LPM (Low Power Mode) which sets VR output to 0V using ZVM# signal. In order to achieve better power/performance it is recommended to use a separate VR for VCCEOPIO in this case VCCEOPIO is configurable to 0.8V/1V. The processor drives the VR to set VCCEOPIO value(0.8V/1V) using MSM# signal, based on the required bandwidth for the EOPIO interface as shown below:

ZVM# state	MSM# state	VCCEOPIO
0V	X	0V
1V	0V	0.8V
1V	1V	1V

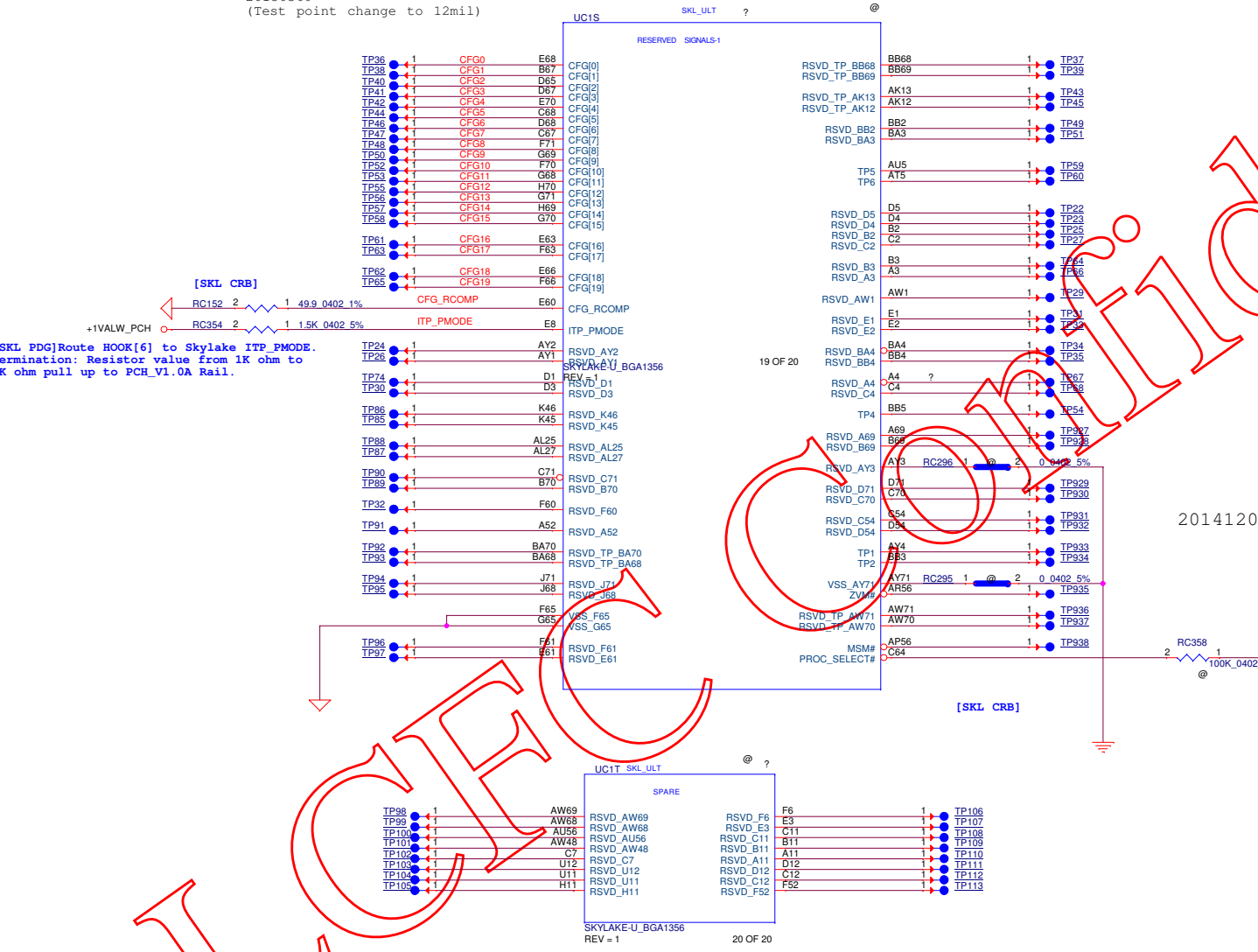

20141202

Security ROM

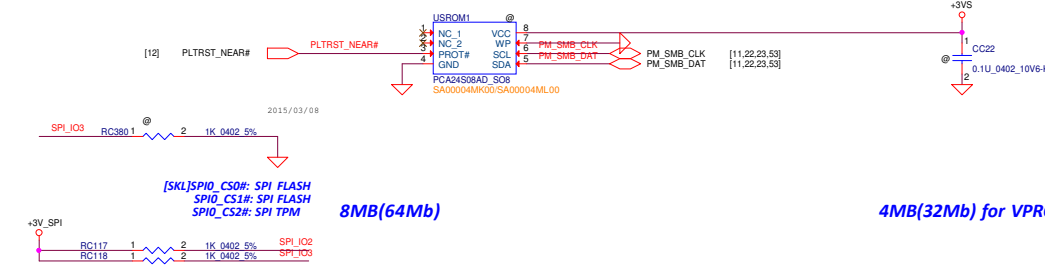

M3 Support + Intel LAN PHY / Wireless LAN Solution

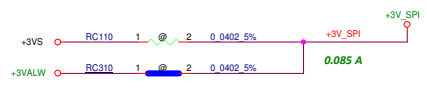

[SKL]SPI0_CS0#: SPI FLASH
 SPI0_CS1#: SPI FLASH
 SPI0_CS2#: SPI TPM

8MB(64Mb)

4MB(32Mb) for VPRO SKU

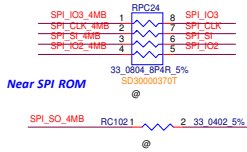
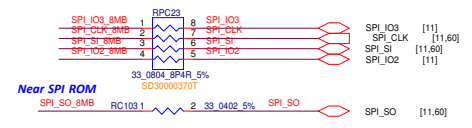
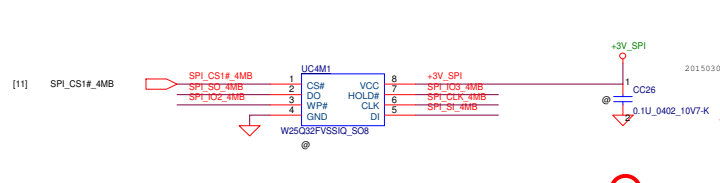
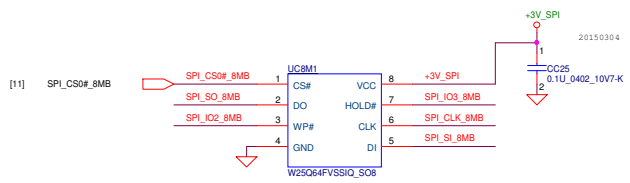

Mirror Code

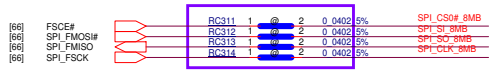

Close to SPI ROM (UC8M1).

Confidential

LCFEC

Security Classification	LC Future Center Secret Data		Title	
Issued Date	2013/09/07	Deciphered Date	2014/09/07	
THIS SHEET OF ENGINEERING DRAWING IS THE PROPRIETARY PROPERTY OF LC FUTURE CENTER, AND CONTAINS CONFIDENTIAL AND TRADE SECRET INFORMATION. THIS SHEET MAY NOT BE TRANSFERRED FROM THE CUSTODY OF THE COMPETENT DIVISION OF R&D DEPARTMENT EXCEPT AS AUTHORIZED BY LC FUTURE CENTER. NEITHER THIS SHEET NOR THE INFORMATION IT CONTAINS MAY BE USED BY OR DISCLOSED TO ANY THIRD PARTY WITHOUT PRIOR WRITTEN CONSENT OF LC FUTURE CENTER.				Size C
			Document Number	Rev 1.0
			BE460_NW-A551	
			Date: Wednesday, August 05, 2015	Sheet 21 of 83

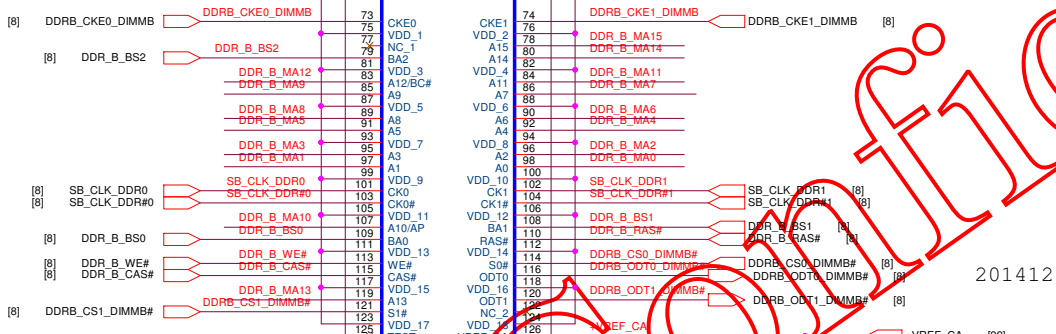
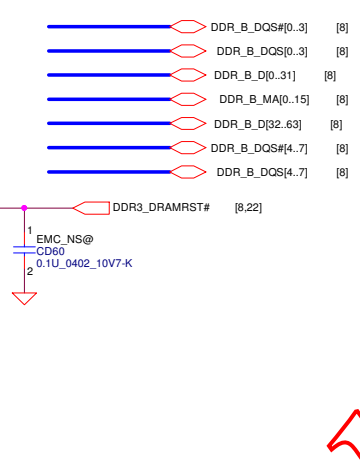
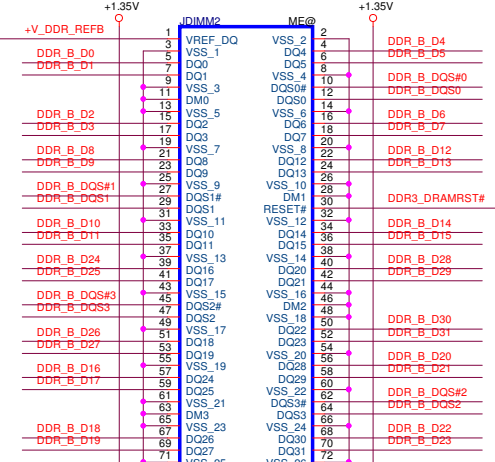
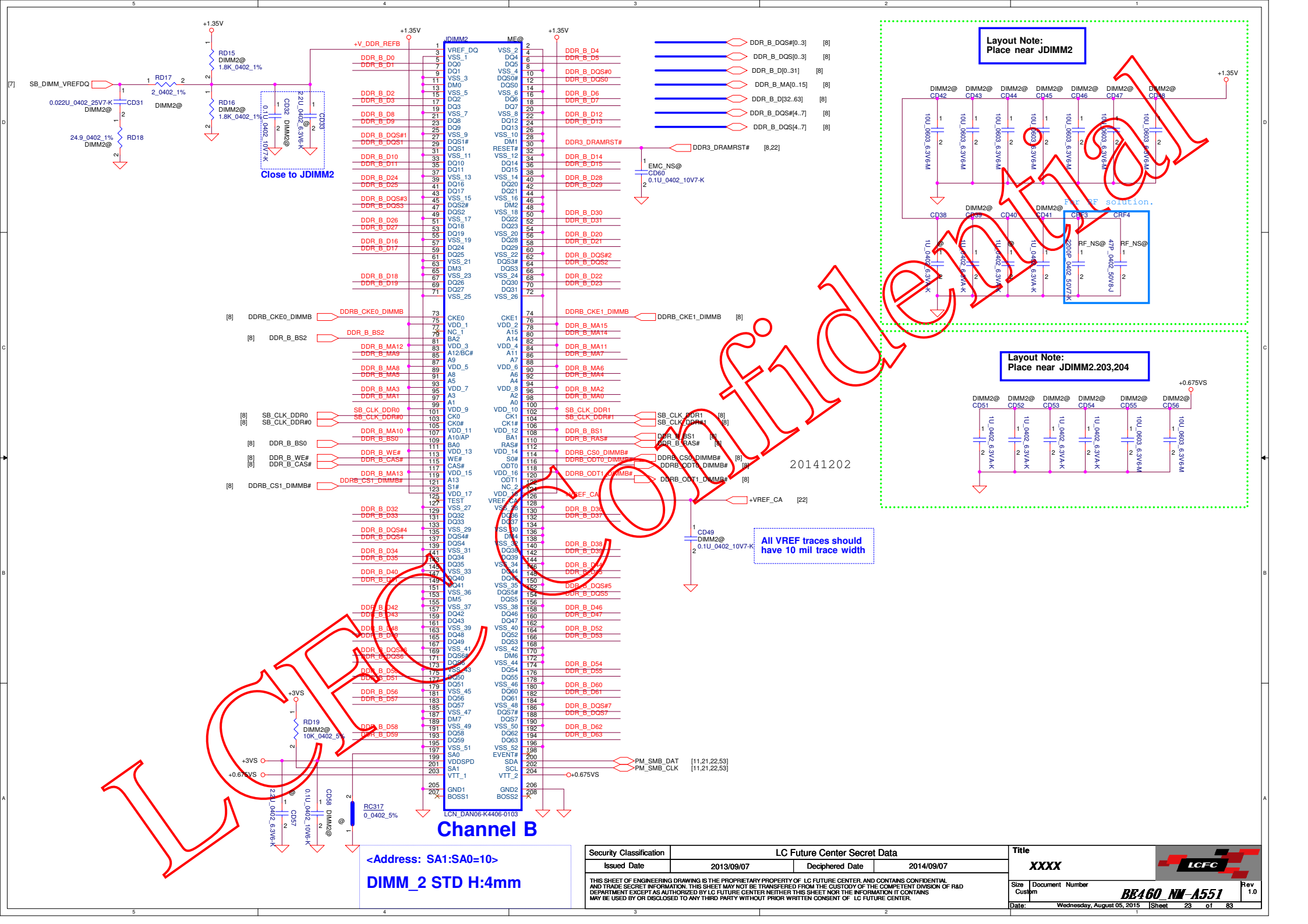

- [15] PCIE_CTX_C_GRX_N[0..3] \rightarrow PCIE_CTX_C_GRX_N[0..3]
- [15] PCIE_CTX_C_GRX_P[0..3] \rightarrow PCIE_CTX_C_GRX_P[0..3]
- [15] PCIE_CTX_GTX_N[0..3] \rightarrow PCIE_CTX_GTX_N[0..3]
- [15] PCIE_CTX_GTX_P[0..3] \rightarrow PCIE_CTX_GTX_P[0..3]

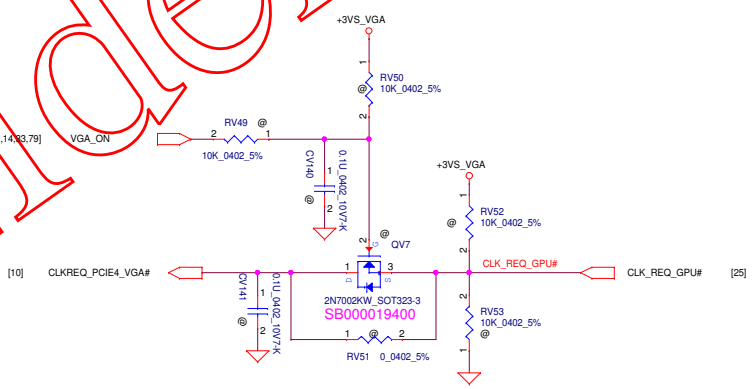
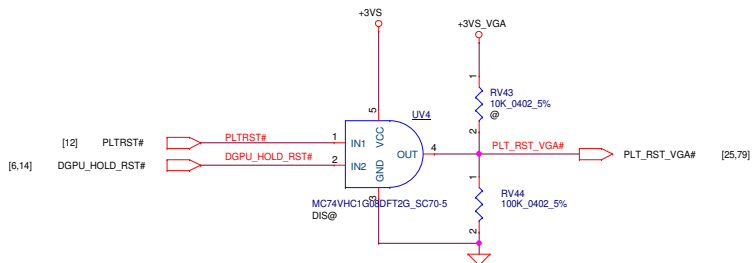
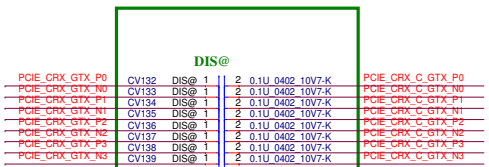

LOEC

Security Classification		LC Future Center Secret Data		Title	
Issued Date	2013/09/07	Deciphered Date	2014/09/07	Topaz & Jet PCIE	
THIS SHEET OF ENGINEERING DRAWING IS THE PROPRIETARY PROPERTY OF LC FUTURE CENTER AND CONTAINS CONFIDENTIAL AND TRADE SECRET INFORMATION. THIS SHEET MAY NOT BE TRANSFERRED FROM THE CUSTODY OF THE COMPETENT DIVISION OF R&D DEPARTMENT EXCEPT AS AUTHORIZED BY LC FUTURE CENTER. NEITHER THIS SHEET NOR THE INFORMATION IT CONTAINS MAY BE USED BY OR DISCLOSED TO ANY THIRD PARTY WITHOUT PRIOR WRITTEN CONSENT OF LC FUTURE CENTER.					
Size	Custom	Document Number	BE460 NW-A551		Rev
Date	Wednesday, August 05, 2015	Sheet	24	of	83

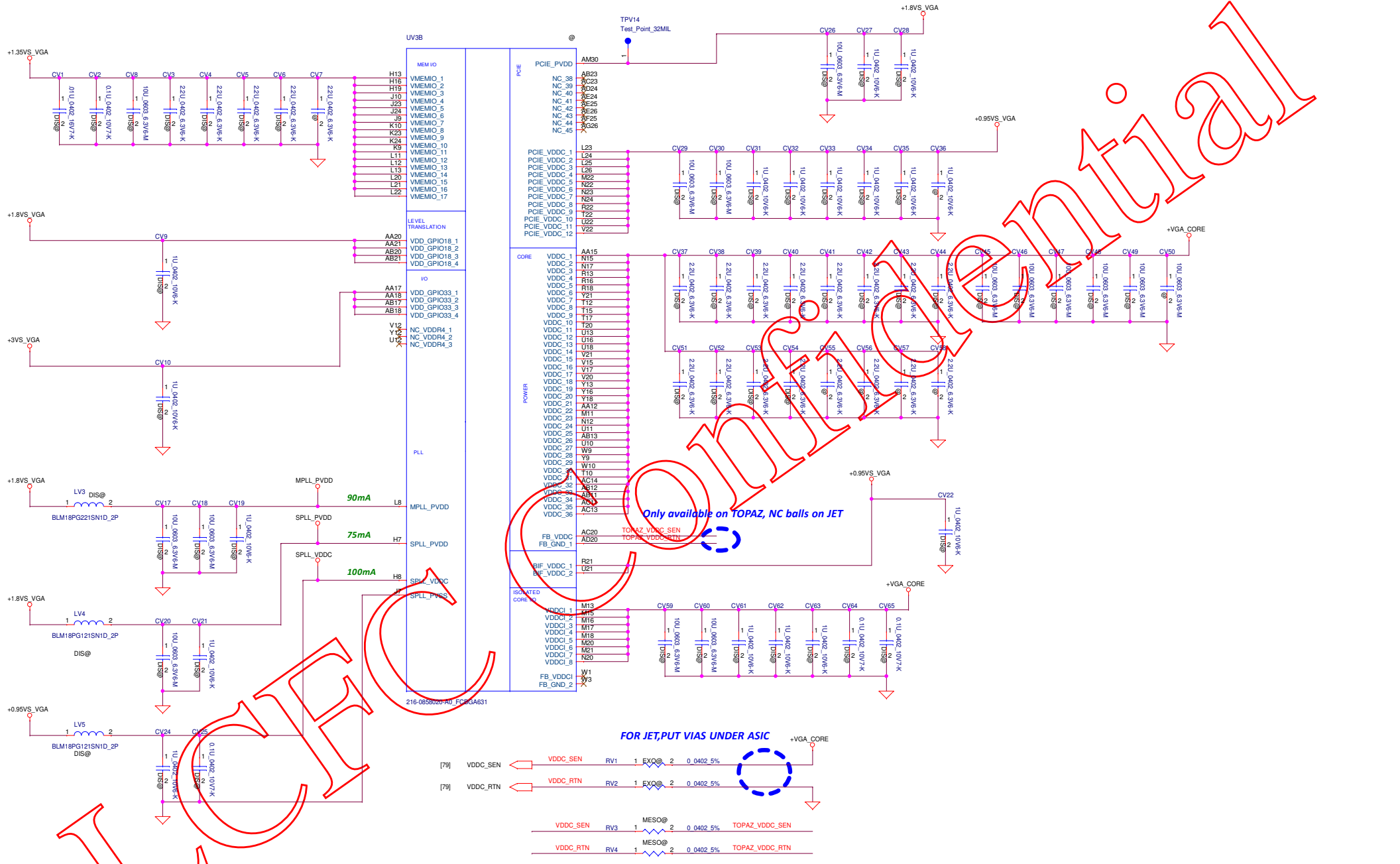

[79]	VDDC_SEN	VDDC_SEN	RV1	1	EXQ@	2	0.0402	5%	
[79]	VDDC_RTN	VDDC_RTN	RV2	1	EXQ@	2	0.0402	5%	
		MESO@							
	VDDC_SEN	RV3	1			2	0.0402	5%	TOPAZ_VDDC_SEN
	VDDC_RTN	RV4	1			2	0.0402	5%	TOPAZ_VDDC_RTN

Security Classification		LC Future Center Secret Data		Title	
Issued Date	2013/09/07	Deciphered Date	2014/09/07	Topaz & Jet Core Power	
THIS SHEET OF ENGINEERING DRAWING IS THE PROPRIETARY PROPERTY OF LC FUTURE CENTER AND CONTAINS CONFIDENTIAL AND TRADE SECRET INFORMATION. THIS SHEET MAY NOT BE TRANSFERRED FROM THE CUSTODY OF THE COMPETENT DIVISION OF R&D DEPARTMENT EXCEPT AS AUTHORIZED BY LC FUTURE CENTER. NEITHER THIS SHEET NOR THE INFORMATION IT CONTAINS MAY BE USED BY OR DISCLOSED TO ANY THIRD PARTY WITHOUT PRIOR WRITTEN CONSENT OF LC FUTURE CENTER.					
Size	Document Number	Date		Rev	
	BE460 NW-A551	Wednesday, August 05, 2015		1.0	
		Sheet 26 of 83			

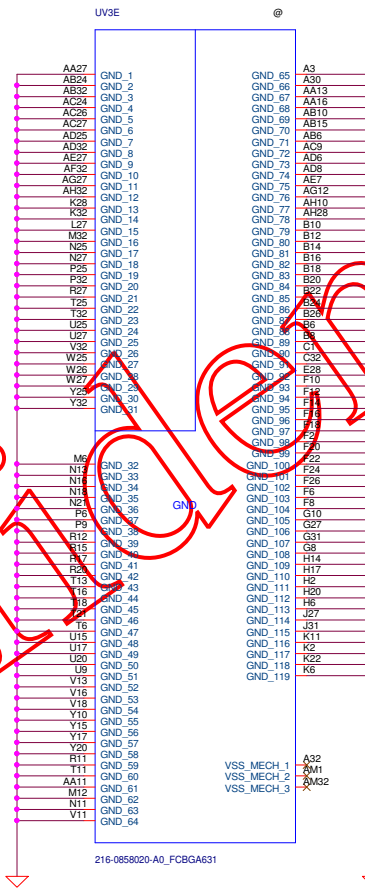
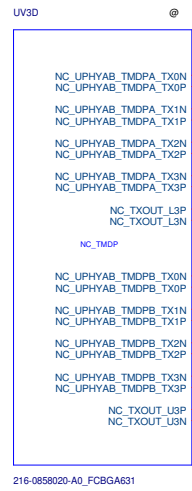
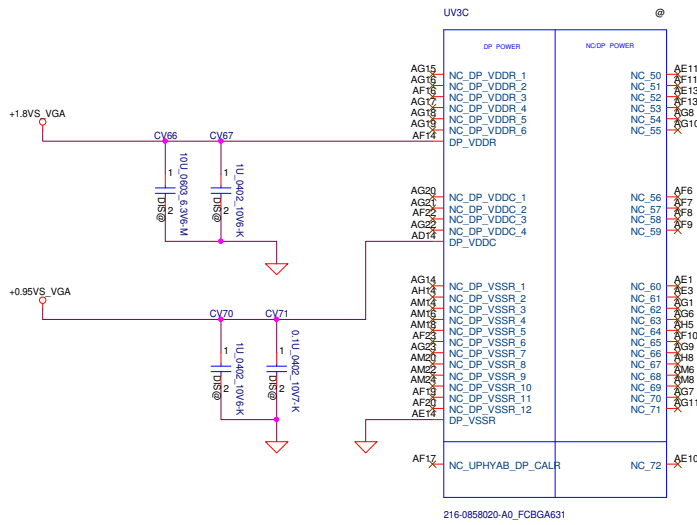

ASIC Ball	Topaz	Jet
U10, T10 AB13, W9 AB11, AB12 AC11, AC13 AC14, Y9, W10	VDDC	NC
AC20	FB_VDDC	NC
AD20	FB_VSS	NC
W1	FB_VDDCI	NC
W3	FB_VSS	NC
AJ11	GPIO_SVC	NC_SVI2
AK12	GPIO_SVD	NC_SVI2
AL11	GPIO_SVT	NC_SVI2
N6	GPIO_11	NC_GPIO11
N5	GPIO_12	NC_GPIO12
N3	GPIO_13	NC_GPIO13
AJ27	WAKEB	NC_VSYNC
T8	PCC/GPIO_6	GPIO_6
AA	PLL_ANALOG_OUT	NC
AA1	PLL_ANALOG_IN	NC

ASIC Ball	Topaz	Jet
U1	BP_0	NC
U3	BP_1	NC
AM26	DIECRACKMON	NC
Y11	NC	DBG_DATA13
AE9	NC	DBG_DATA14
L9	NC	DBG_DATA15
N9	NC	DBG_DATA16
AE8	NC	DBG_DATA12
AL9	NC	DBG_CNTL0
H13, H16, H19, F10 F9, F24, W9, K10 K23, K24, K9, L11 L12, L13, L20, L21 L22	VDDMIO	VDDR1
AA17, AA18 AB17, AB18	VDD_GPIO33	VDDR3
AA20, AA21 AB20, AB21	VDD_GPIO18	VDD_CT

	Bits5	Bits4	Bits3	Bits2	Bits1
PS0	1	1	0	0	1
PS1	1	1	0	0	0
PS2	0	0	0	0	0
PS3	1	1	?	?	?

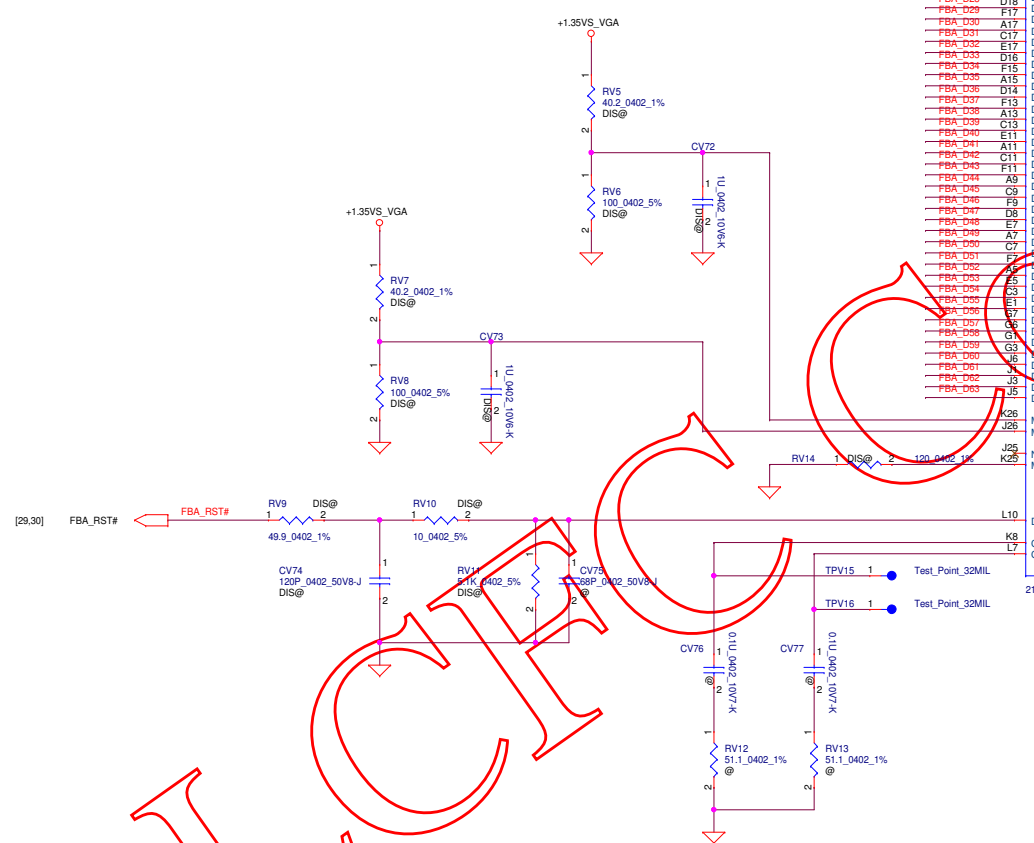
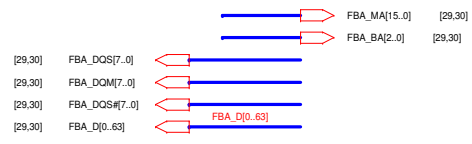

UV3F @

Pin	Signal	Pin	Signal	
FBA_D0	K27	DDA0_0	MAA0_0	
FBA_D1	K28	DDA0_1	MAA0_1	
FBA_D2	H50	DDA0_2	MAA0_2	
FBA_D3	H32	DDA0_3	MAA0_3	
FBA_D4	G29	DDA0_4	MAA0_4	
FBA_D5	F28	DDA0_5	MAA0_5	
FBA_D6	F32	DDA0_6	MAA0_6	
FBA_D7	F30	DDA0_7	MAA0_7	
FBA_D8	C30	DDA0_8	MAA0_8	
FBA_D9	F27	DDA0_9	MAA0_9	
FBA_D10	A28	DDA0_10	MAA1_0	
FBA_D11	G28	DDA0_11	MAA1_1	
FBA_D12	E27	DDA0_12	MAA1_2	
FBA_D13	G26	DDA0_13	MAA1_3	
FBA_D14	D26	DDA0_14	MAA1_4	
FBA_D15	F25	DDA0_15	MAA1_5	
FBA_D16	A25	DDA0_16	MAA1_6	
FBA_D17	C25	DDA0_17	MAA1_7	
FBA_D18	E25	DDA0_18	MAA1_8	
FBA_D19	D24	DDA0_19	MAA1_9	
FBA_D20	E23	DDA0_20	E32	FBA_DOM0
FBA_D21	F23	DDA0_21	E30	FBA_DOM1
FBA_D22	D22	DDA0_22	A21	FBA_DOM2
FBA_D23	F21	DDA0_23	E21	FBA_DOM3
FBA_D24	E21	DDA0_24	E13	FBA_DOM4
FBA_D25	D20	DDA0_25	D12	FBA_DOM5
FBA_D26	F19	DDA0_26	E3	FBA_DOM6
FBA_D27	A19	DDA0_27	F2	FBA_DOM7
FBA_D28	D19	DDA0_28	E28	FBA_DQ0
FBA_D29	F17	DDA0_29	C27	FBA_DQ01
FBA_D30	A17	DDA0_30	A23	FBA_DQ02
FBA_D31	C17	DDA0_31	E19	FBA_DQ03
FBA_D32	E17	DDA1_0	E15	FBA_DQ04
FBA_D33	D16	DDA1_1	D19	FBA_DQ05
FBA_D34	F15	DDA1_2	E25	FBA_DQ06
FBA_D35	A15	DDA1_3	D25	FBA_DQ07
FBA_D36	D14	DDA1_4	E27	FBA_DQ08
FBA_D37	F13	DDA1_5	A27	FBA_DQ09
FBA_D38	A13	DDA1_6	E27	FBA_DQ10
FBA_D39	C13	DDA1_7	E27	FBA_DQ11
FBA_D40	E11	DDA1_8	E27	FBA_DQ12
FBA_D41	A11	DDA1_9	E27	FBA_DQ13
FBA_D42	C11	DDA1_10	E27	FBA_DQ14
FBA_D43	F11	DDA1_11	E27	FBA_DQ15
FBA_D44	A9	DDA1_12	E27	FBA_DQ16
FBA_D45	C9	DDA1_13	E27	FBA_DQ17
FBA_D46	F9	DDA1_14	E27	FBA_DQ18
FBA_D47	D8	DDA1_15	E27	FBA_DQ19
FBA_D48	E7	DDA1_16	E27	FBA_DQ20
FBA_D49	A7	DDA1_17	E27	FBA_DQ21
FBA_D50	C7	DDA1_18	E27	FBA_DQ22
FBA_D51	F7	DDA1_19	E27	FBA_DQ23
FBA_D52	A5	DDA1_20	E27	FBA_DQ24
FBA_D53	C5	DDA1_21	E27	FBA_DQ25
FBA_D54	F5	DDA1_22	E27	FBA_DQ26
FBA_D55	A3	DDA1_23	E27	FBA_DQ27
FBA_D56	C3	DDA1_24	E27	FBA_DQ28
FBA_D57	F3	DDA1_25	E27	FBA_DQ29
FBA_D58	A1	DDA1_26	E27	FBA_DQ30
FBA_D59	C1	DDA1_27	E27	FBA_DQ31
FBA_D60	F1	DDA1_28	E27	FBA_DQ32
FBA_D61	A0	DDA1_29	E27	FBA_DQ33
FBA_D62	C0	DDA1_30	E27	FBA_DQ34
FBA_D63	F0	DDA1_31	E27	FBA_DQ35

CONFIDENTIAL

Security Classification		LC Future Center Secret Data		Title	
Issued Date	2013/09/07	Deciphered Date	2014/09/07	Topaz & Jet MEM Interface	
<small>THIS SHEET OF ENGINEERING DRAWING IS THE PROPRIETARY PROPERTY OF LC FUTURE CENTER AND CONTAINS CONFIDENTIAL AND TRADE SECRET INFORMATION. THIS SHEET MAY NOT BE TRANSFERRED FROM THE CUSTODY OF THE COMPETENT DIVISION OF R&D DEPARTMENT EXCEPT AS AUTHORIZED BY LC FUTURE CENTER. NEITHER THIS SHEET NOR THE INFORMATION IT CONTAINS MAY BE USED BY OR DISCLOSED TO ANY THIRD PARTY WITHOUT PRIOR WRITTEN CONSENT OF LC FUTURE CENTER.</small>					
Size	Document	Number	BE460 NW-A551		Rev
Date:	Wednesday, August 05, 2015	Sheet	28	of	83

Memory Partition A - Lower 32 bits

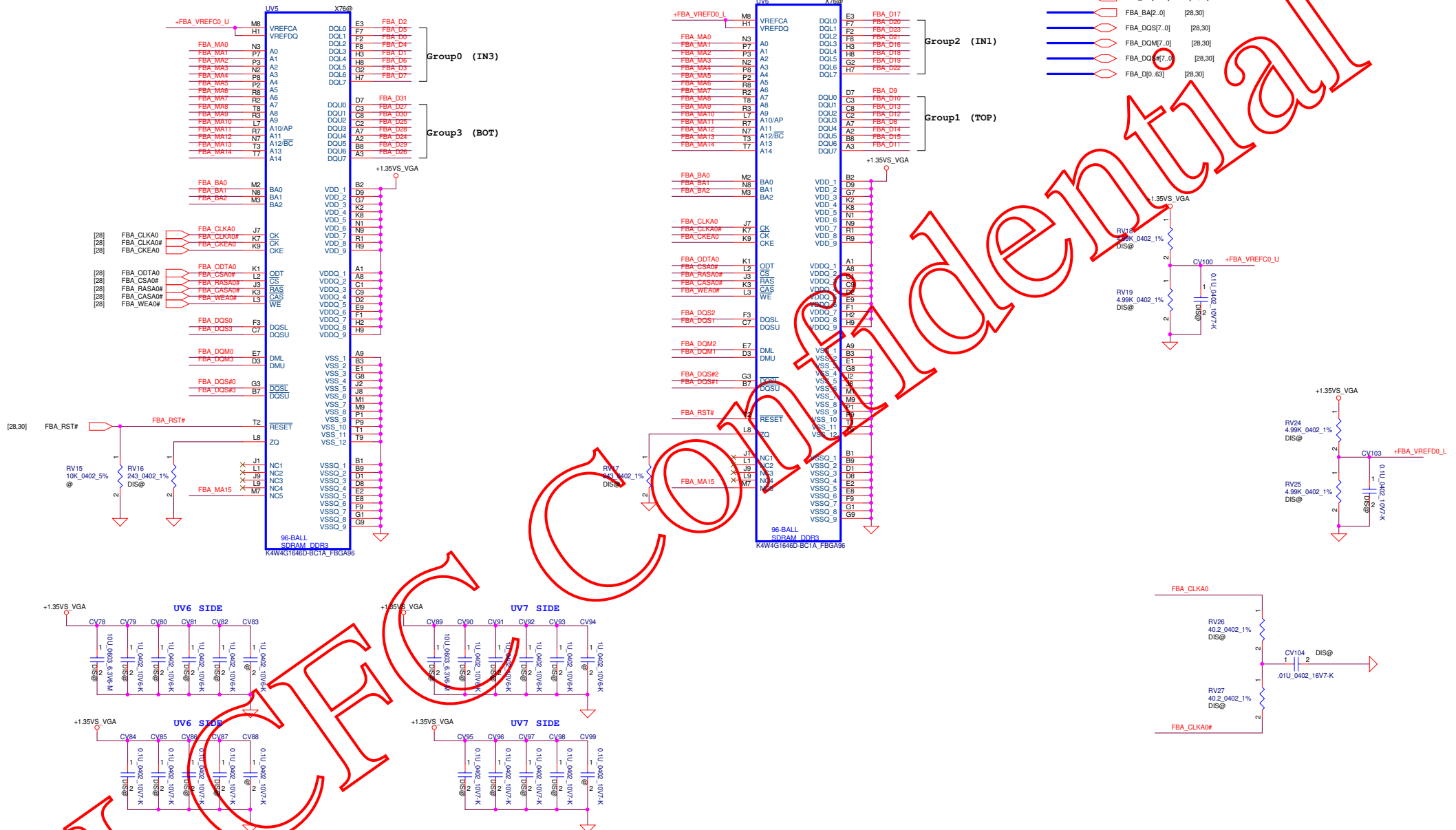

Memory Partition A - Upper 32 bits

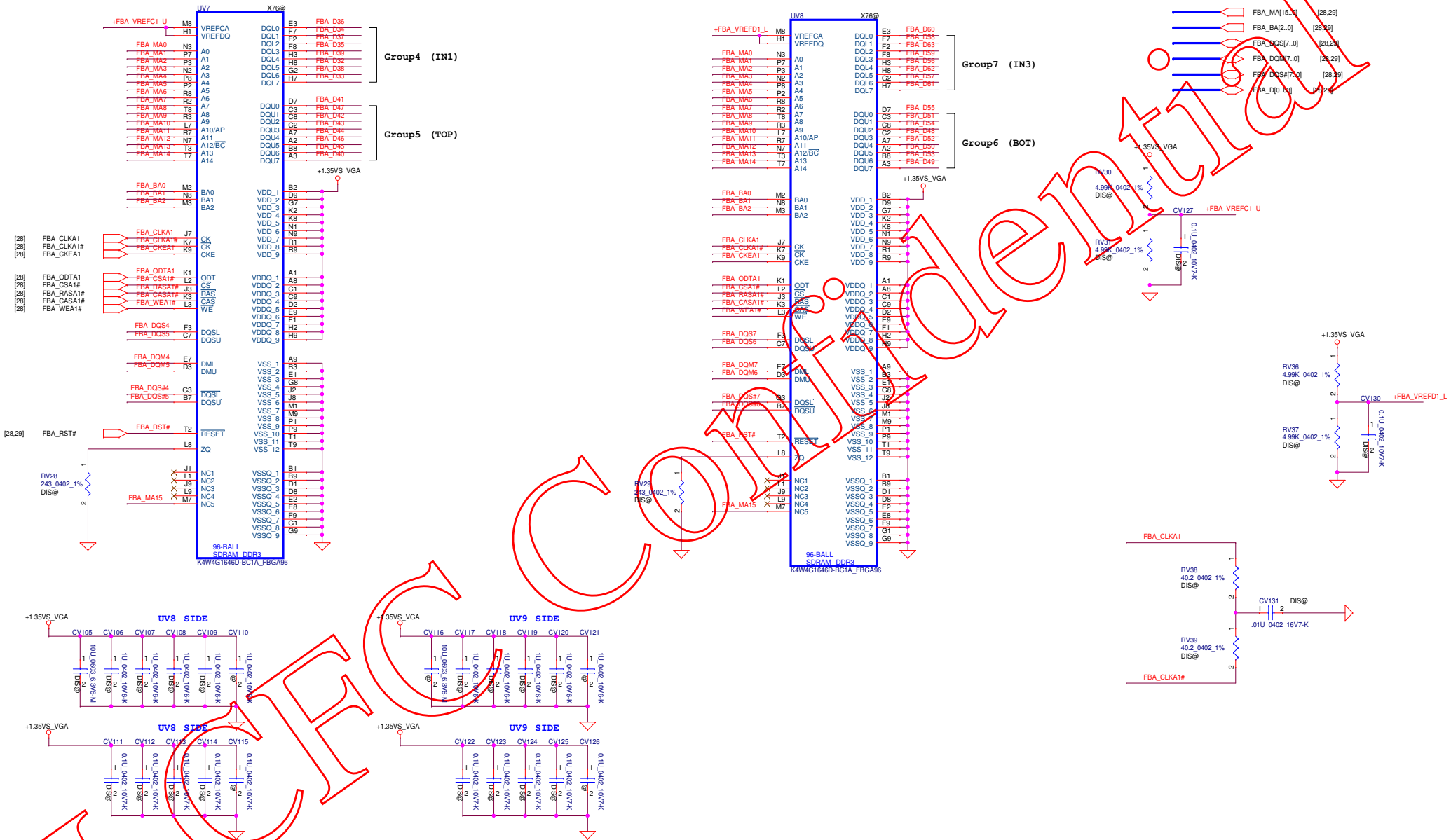

LCFEC Confidential

Security Classification	LC Future Center Secret Data			Title	
Issued Date	2013/09/07	Deciphered Date	2014/09/07	XXXX	
<small>THIS SHEET OF ENGINEERING DRAWING IS THE PROPRIETARY PROPERTY OF LC FUTURE CENTER, AND CONTAINS CONFIDENTIAL AND TRADE SECRET INFORMATION. THIS SHEET MAY NOT BE TRANSFERRED FROM THE CUSTODY OF THE COMPETENT DIVISION OF R&D DEPARTMENT EXCEPT AS AUTHORIZED BY LC FUTURE CENTER NEITHER THIS SHEET NOR THE INFORMATION IT CONTAINS MAY BE USED BY OR DISCLOSED TO ANY THIRD PARTY WITHOUT PRIOR WRITTEN CONSENT OF LC FUTURE CENTER.</small>					Size Document Number Rev Custom BEAGO NM-A551 1.0
Date: Wednesday, August 05, 2015					Sheet 31 of 83

LCFC Confidential

Security Classification	LC Future Center Secret Data		Title	
Issued Date	2013/09/07	Deciphered Date	2014/09/07	
<small>THIS SHEET OF ENGINEERING DRAWING IS THE PROPRIETARY PROPERTY OF LC FUTURE CENTER, AND CONTAINS CONFIDENTIAL AND TRADE SECRET INFORMATION. THIS SHEET MAY NOT BE TRANSFERRED FROM THE CUSTODY OF THE COMPETENT DIVISION OF R&D DEPARTMENT EXCEPT AS AUTHORIZED BY LC FUTURE CENTER NEITHER THIS SHEET NOR THE INFORMATION IT CONTAINS MAY BE USED BY OR DISCLOSED TO ANY THIRD PARTY WITHOUT PRIOR WRITTEN CONSENT OF LC FUTURE CENTER.</small>				Size Document Number Rev Custom BEAGO NM-A551 1.0
Date: Wednesday, August 05, 2015				Sheet 32 of 83

+1.35V to +1.35VS_VGA

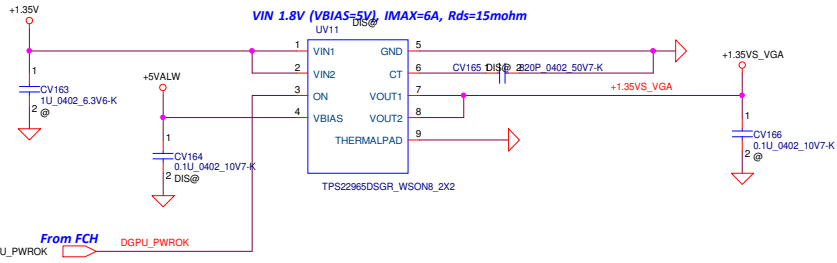

+1.8VALW to +1.8VS_VGA

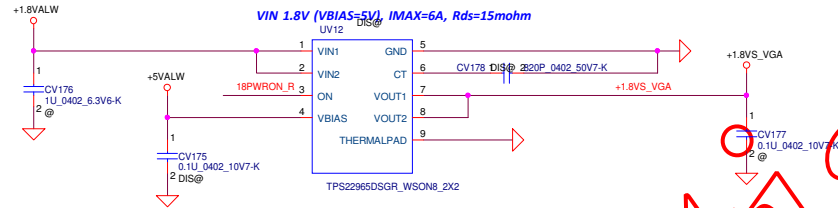

MLPS	Bit				
	5	4	3	2	1
PS_0[5:1]	1	1	0	0	1
PS_1[5:1]	1	1	0	0	0
PS_2[5:1]	1	1	0	0	0
PS_3[5:1]	1	1	X	X	X

+1VALW to +1VS_VGA

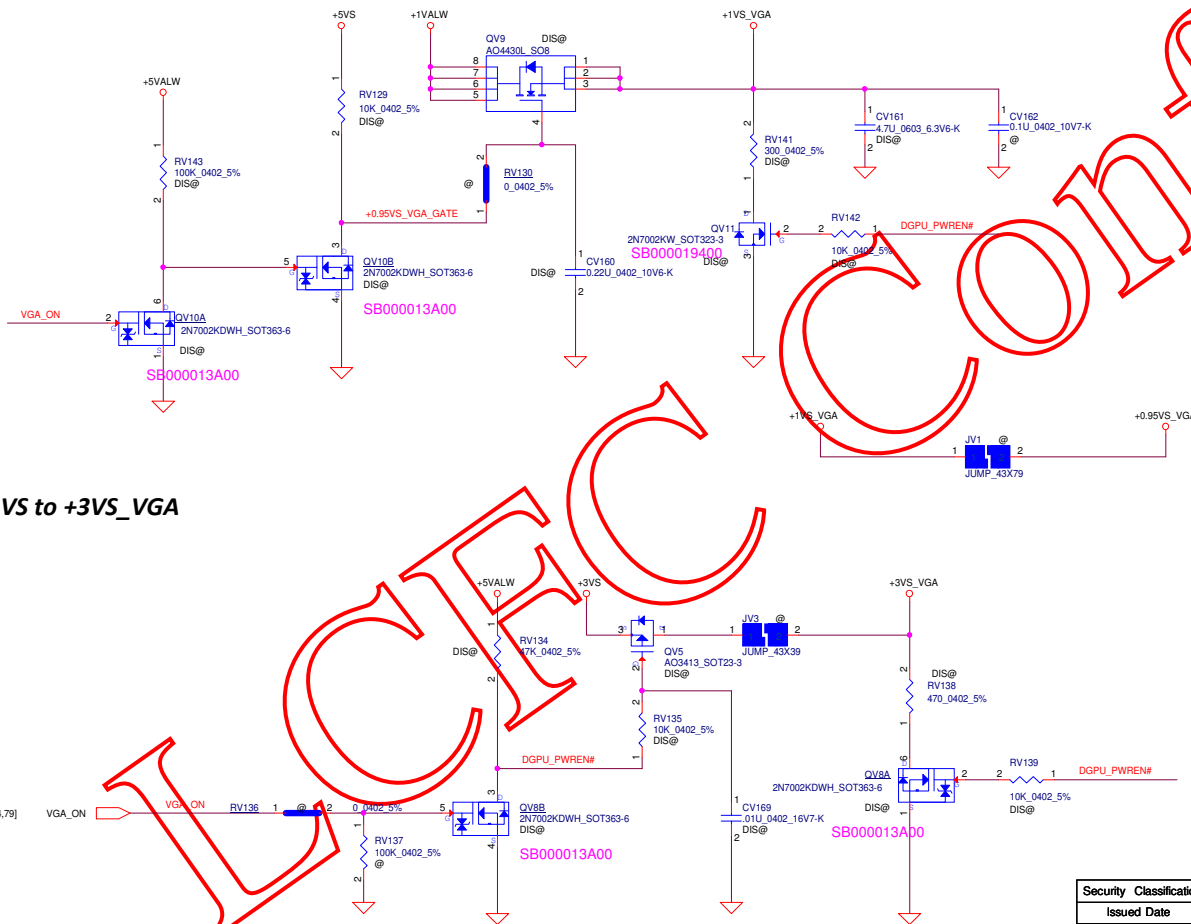

+3VS to +3VS_VGA

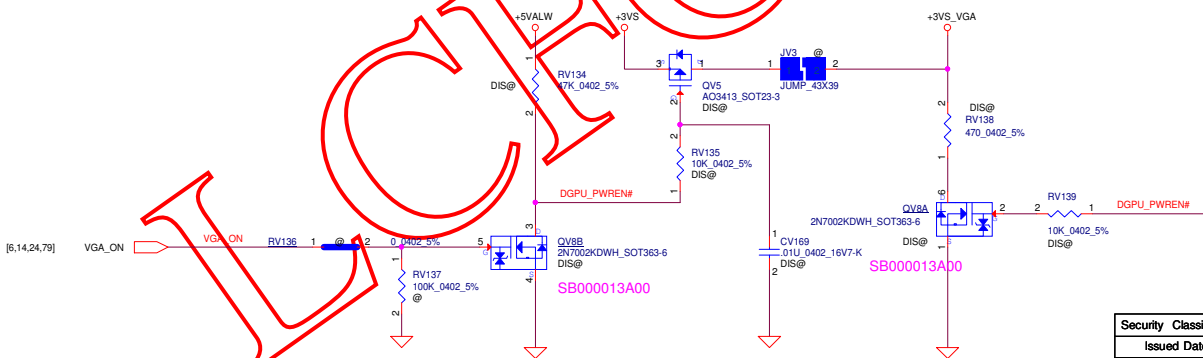

PS_0[1]	ROM_CONFIG[0]	STRAP BIOS_ROM_EN = 1 ROM_CONFIG[2:0] = [001] 256MB
PS_0[2]	ROM_CONFIG[1]	
PS_0[3]	ROM_CONFIG[2]	
PS_0[4]	N/A	1 (Default)
PS_0[5]	N/A	1 (Default)
PS_1[1]	STRAP_BIF_GEN3_EN_A	0 = PCIe GEN3 is not supported
PS_1[2]	STRAP_BIF_CLK_PM_EN	0 = The CLKREQB power management capability is disabled
PS_1[3]	N/A	0 (Default)
PS_1[4]	STRAP_TX_CFG_DRV_FULL_SWING	1 = The transmitter full-swing is enabled
PS_1[5]	STRAP_TX_DEEMPH_EN	1 = Tx deemphasis enabled
PS_2[1]	N/A	0 (Default)
PS_2[2]	N/A	0 (Default)
PS_2[3]	STRAP_BIOS_ROM_EN	0 = Disable the external BIOS ROM device
PS_2[4]	N/A	1 (Default)
PS_2[5]	N/A	1 (Default)
PS_3[1]	BOARD_CONFIG[0]	PS_3[3..1] 101 = Micron 2G 110 = Samsung 2G 111 = Hynix 2G
PS_3[2]	BOARD_CONFIG[1]	
PS_3[3]	BOARD_CONFIG[2]	
PS_3[4]	N/A	1 (Default)
PS_3[5]	N/A	1 (Default)

LCFEC Confidential

Security Classification	LC Future Center Secret Data			Title	
Issued Date	2013/09/07	Deciphered Date	2014/09/07	XXXX	
<small>THIS SHEET OF ENGINEERING DRAWING IS THE PROPRIETARY PROPERTY OF LC FUTURE CENTER, AND CONTAINS CONFIDENTIAL AND TRADE SECRET INFORMATION. THIS SHEET MAY NOT BE TRANSFERRED FROM THE CUSTODY OF THE COMPETENT DIVISION OF R&D DEPARTMENT EXCEPT AS AUTHORIZED BY LC FUTURE CENTER NEITHER THIS SHEET NOR THE INFORMATION IT CONTAINS MAY BE USED BY OR DISCLOSED TO ANY THIRD PARTY WITHOUT PRIOR WRITTEN CONSENT OF LC FUTURE CENTER.</small>					Size Document Number Custom BEAGO NM-A551
					Date: Wednesday, August 05, 2015 Sheet 34 of 83 Rev 1.0

LCFEC Confidential

Security Classification	LC Future Center Secret Data			Title	XXXX	
Issued Date	2013/09/07	Deciphered Date	2014/09/07	Size	Custom	Document Number
THIS SHEET OF ENGINEERING DRAWING IS THE PROPRIETARY PROPERTY OF LC FUTURE CENTER, AND CONTAINS CONFIDENTIAL AND TRADE SECRET INFORMATION. THIS SHEET MAY NOT BE TRANSFERRED FROM THE CUSTODY OF THE COMPETENT DIVISION OF R&D DEPARTMENT EXCEPT AS AUTHORIZED BY LC FUTURE CENTER NEITHER THIS SHEET NOR THE INFORMATION IT CONTAINS MAY BE USED BY OR DISCLOSED TO ANY THIRD PARTY WITHOUT PRIOR WRITTEN CONSENT OF LC FUTURE CENTER.				Rev		1.0
				Date:	Wednesday, August 05, 2015	Sheet 35 of 83

USB3.0 Repeater Port 3

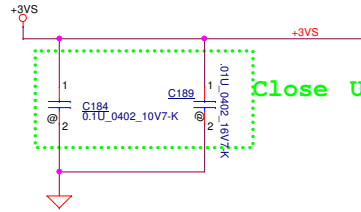

Close U150

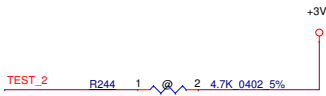
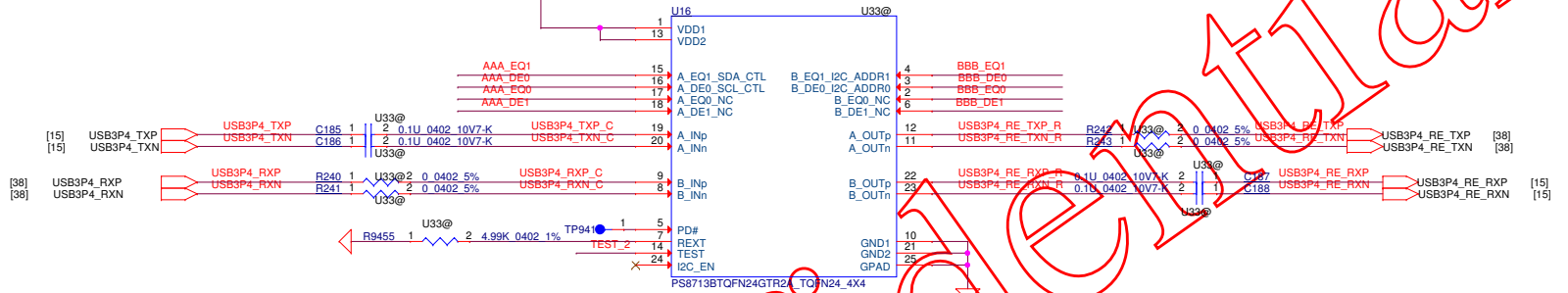

Normal LFPS mode
Internal PD

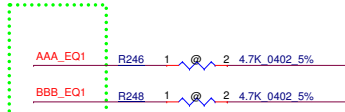

EQ Default 9.5dB
Internal PD



de-emphasis Default 3.5dB
Internal PD

20-lay 0-ohm

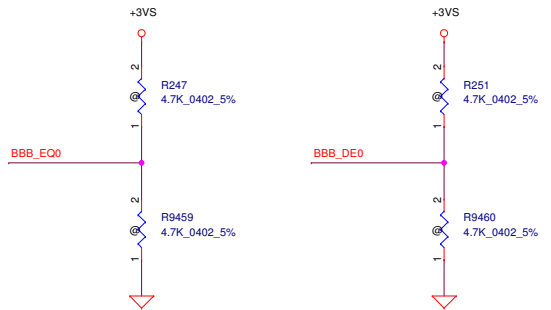
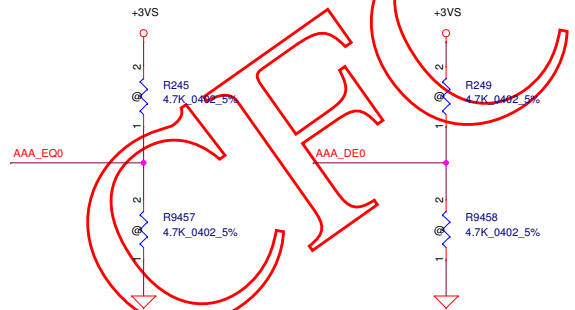
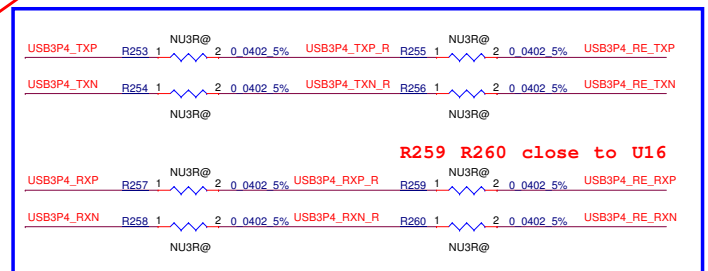

LFC

Security Classification	LC Future Center Secret Data		Title	XXXX	
Issued Date	2013/09/07	Deciphered Date	2014/09/07		
<small>THIS SHEET OF ENGINEERING DRAWING IS THE PROPRIETARY PROPERTY OF LC FUTURE CENTER, AND CONTAINS CONFIDENTIAL AND TRADE SECRET INFORMATION. THIS SHEET MAY NOT BE TRANSFERRED FROM THE CUSTODY OF THE COMPETENT DIVISION OF R&D DEPARTMENT EXCEPT AS AUTHORIZED BY LC FUTURE CENTER NEITHER THIS SHEET NOR THE INFORMATION IT CONTAINS MAY BE USED BY OR DISCLOSED TO ANY THIRD PARTY WITHOUT PRIOR WRITTEN CONSENT OF LC FUTURE CENTER.</small>				Size Custom Document Number BEAGO NM-A551	Rev 1.0
				Date: Wednesday, August 05, 2015	Sheet 36 of 83

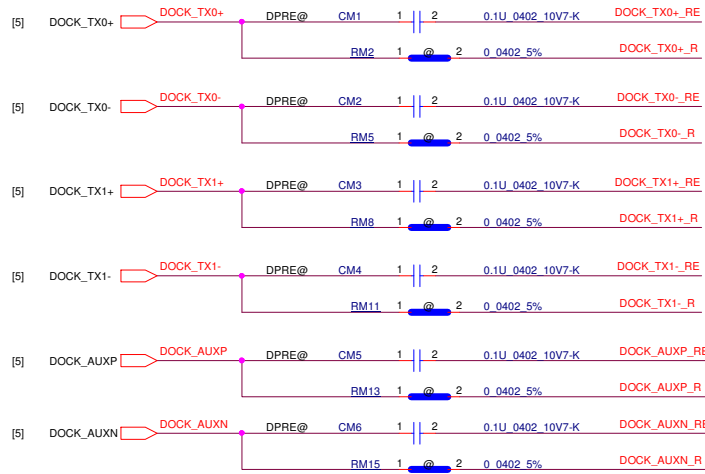

Cap.Pin1 and R.Pin1 Co-lay

One-Link DP Repeater

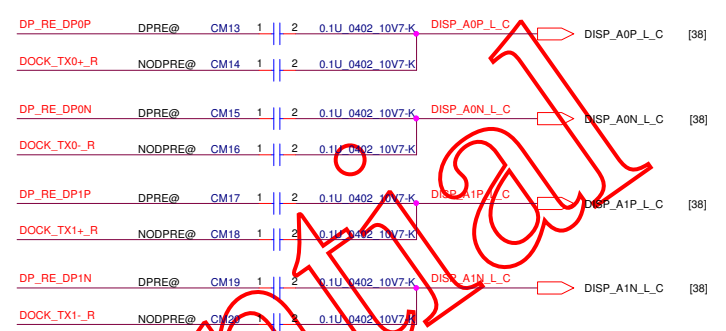
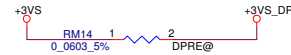

R.Pin2 and R.Pin2 Co-lay

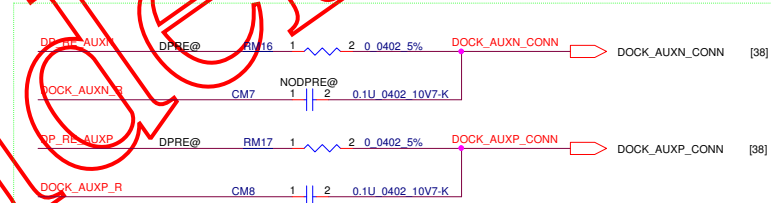

Cap.Pin2 and R.Pin2 Co-lay

DP AUX : From Repeater don't need cap, but PCH.

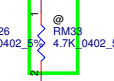
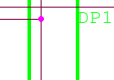
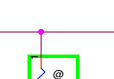
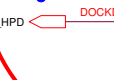
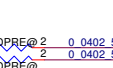
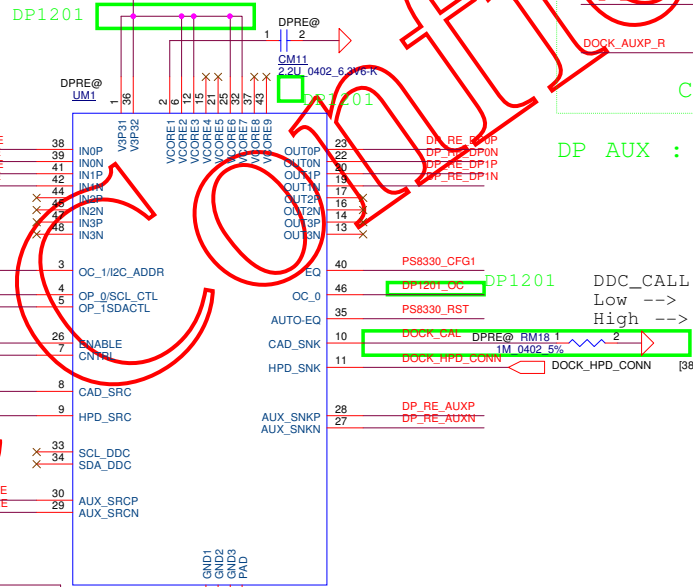
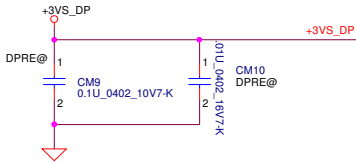

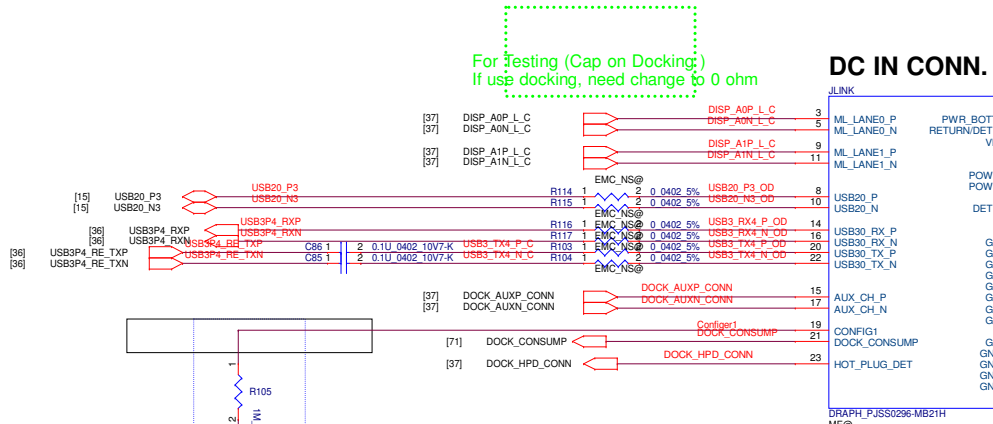

DC IN CONN.

Close to connector

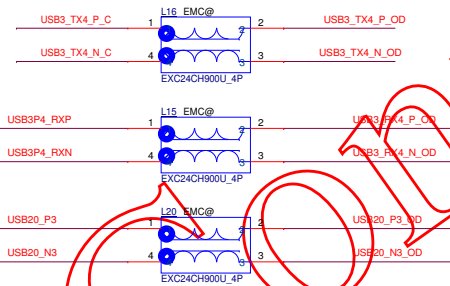
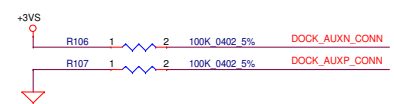

ESD(Close to connector)

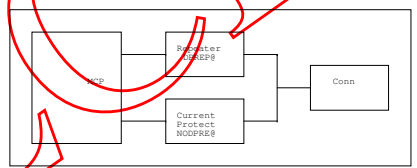
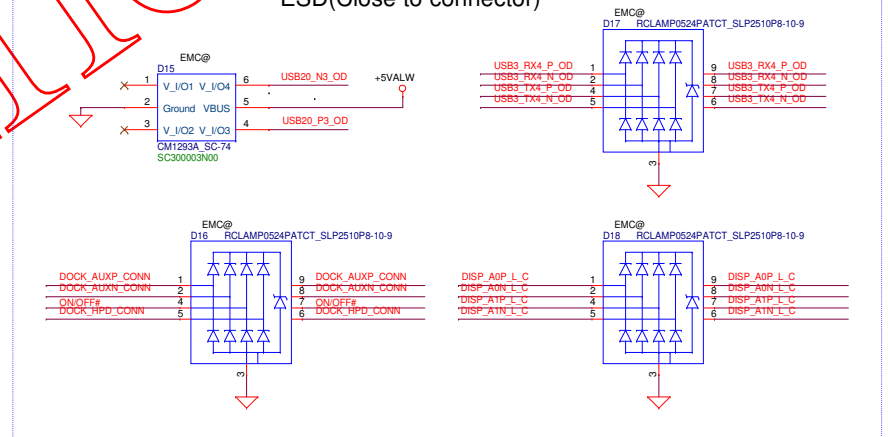

Security Classification		LC Future Center Secret Data		Title	
Issued Date	2013/09/07	Deciphered Date	2014/09/07	DOCKING/ DCIN CONN	
THIS SHEET OF ENGINEERING DRAWING IS THE PROPRIETARY PROPERTY OF LC FUTURE CENTER AND CONTAINS CONFIDENTIAL AND TRADE SECRET INFORMATION. THIS SHEET MAY NOT BE TRANSFERRED FROM THE CUSTODY OF THE COMPETENT DIVISION OF R&D DEPARTMENT EXCEPT AS AUTHORIZED BY LC FUTURE CENTER. NEITHER THIS SHEET NOR THE INFORMATION IT CONTAINS MAY BE USED BY OR DISCLOSED TO ANY THIRD PARTY WITHOUT PRIOR WRITTEN CONSENT OF LC FUTURE CENTER.					
Size	Document	Number	Customer		Rev
			BE460 NW-A551		1.0
Date:	Wednesday, August 05, 2015	Sheet	38	of	83

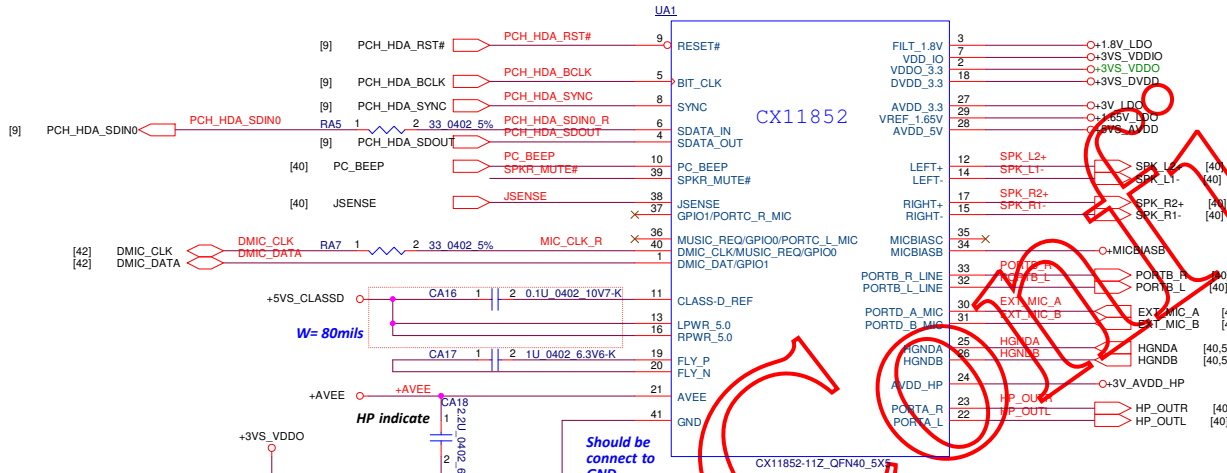
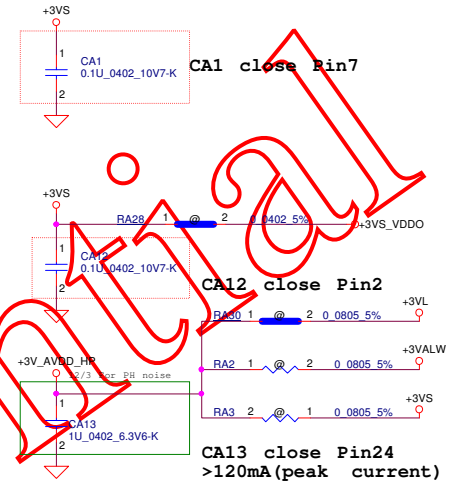
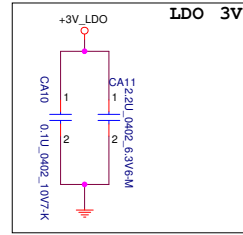
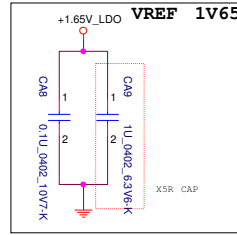
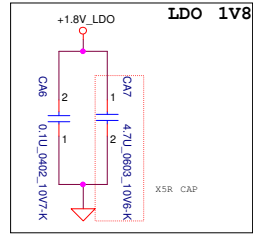
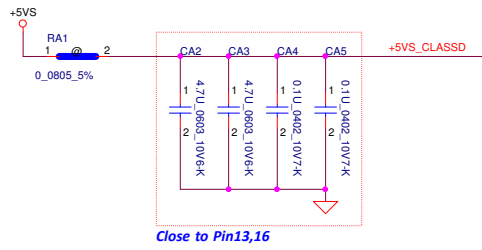

Apple -> EXT_MIC_A, HGND B
 Nokia -> EXT_MIC_B, GNDA
 HGND A/HGND B trace widths should be as wide as possible

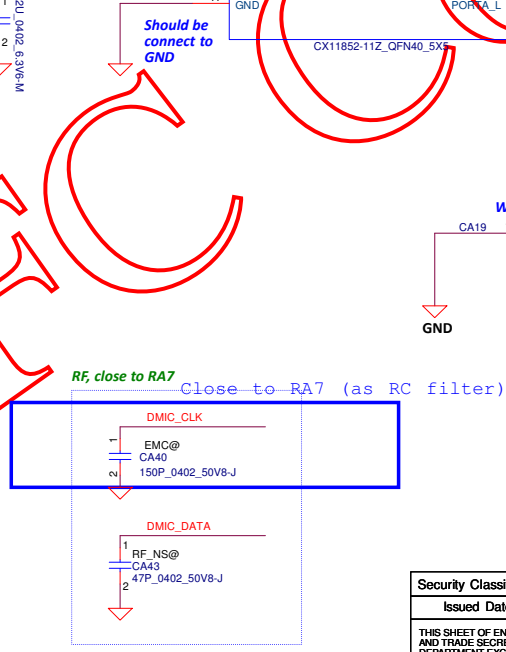
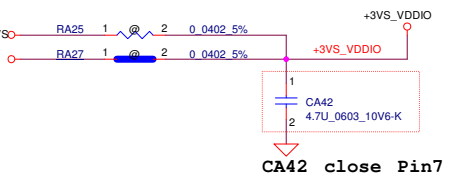
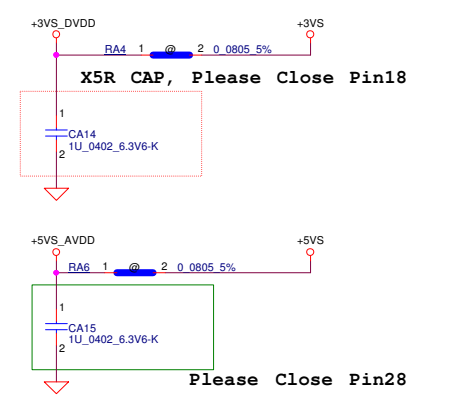

LOEFC

Security Classification	LC Future Center Secret Data			Title
Issued Date	2013/09/07	Deciphered Date	2014/09/07	CX11852 & SPEAKER
THIS SHEET OF ENGINEERING DRAWING IS THE PROPRIETARY PROPERTY OF LC FUTURE CENTER, AND CONTAINS CONFIDENTIAL AND TRADE SECRET INFORMATION. THIS SHEET MAY NOT BE TRANSFERRED FROM THE CUSTODY OF THE COMPETENT DIVISION OF R&D DEPARTMENT EXCEPT AS AUTHORIZED BY LC FUTURE CENTER NEITHER THIS SHEET NOR THE INFORMATION IT CONTAINS MAY BE USED BY OR DISCLOSED TO ANY THIRD PARTY WITHOUT PRIOR WRITTEN CONSENT OF LC FUTURE CENTER.				

Size	Document Number	Rev
Custom	BE60 NM-A551	1.0
Date:	Wednesday, August 05, 2015	Sheet 39 of 83

PC BEEP

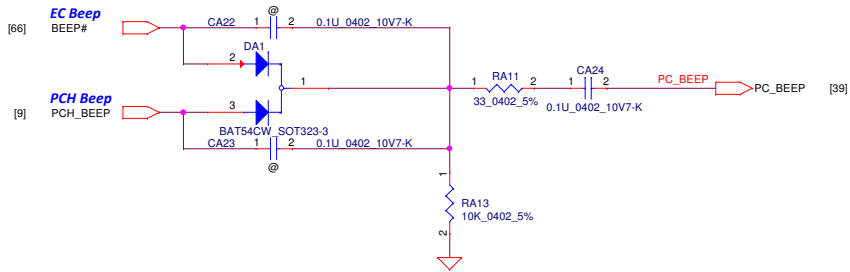

Speaker OUT

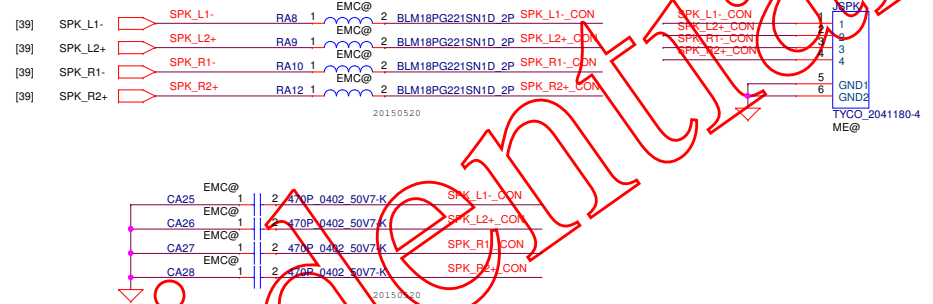

EXT. MIC/LINE IN

Apple --> EXT_MIC_A, HGND B
 Nokia --> EXT_MIC_B, HGND A

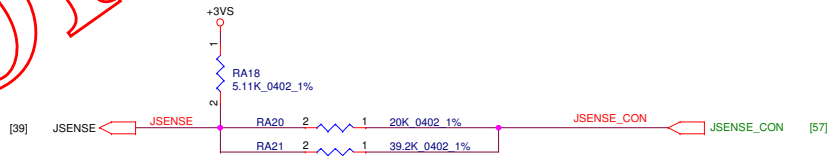
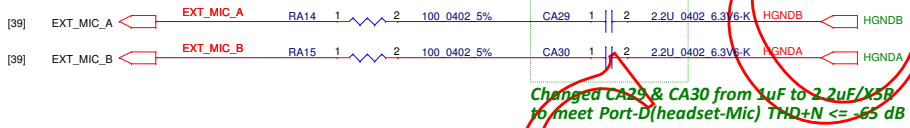

HeadPhone/LINE OUT

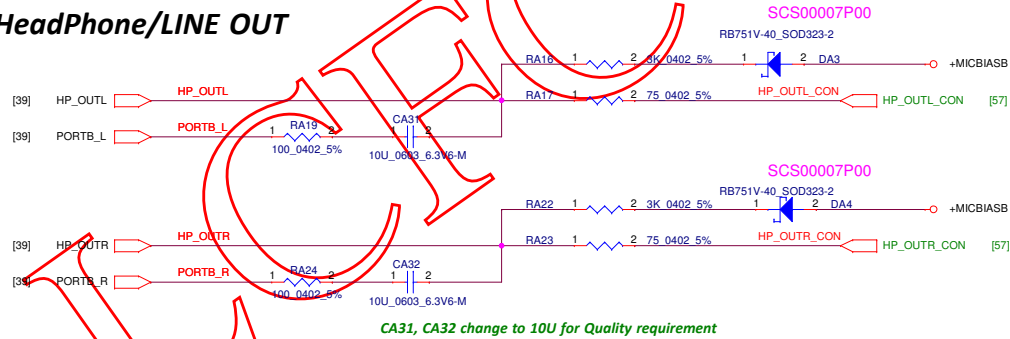

Security Classification	LC Future Center Secret Data	
Issued Date	2013/09/07	Deciphered Date
		2014/09/07

Title	HP/MIC JACK
-------	-------------

THIS SHEET OF ENGINEERING DRAWING IS THE PROPRIETARY PROPERTY OF LC FUTURE CENTER, AND CONTAINS CONFIDENTIAL AND TRADE SECRET INFORMATION. THIS SHEET MAY NOT BE TRANSFERRED FROM THE CUSTODY OF THE COMPETENT DIVISION OF R&D DEPARTMENT EXCEPT AS AUTHORIZED BY LC FUTURE CENTER NEITHER THIS SHEET NOR THE INFORMATION IT CONTAINS MAY BE USED BY OR DISCLOSED TO ANY THIRD PARTY WITHOUT PRIOR WRITTEN CONSENT OF LC FUTURE CENTER.

Size	Document Number	Rev
Custom	BEAGO-NM-A551	1.0
Date:	Wednesday, August 05, 2015	Sheet 40 of 83

CONFIDENTIAL

LCFC

SATA HDD CONN.

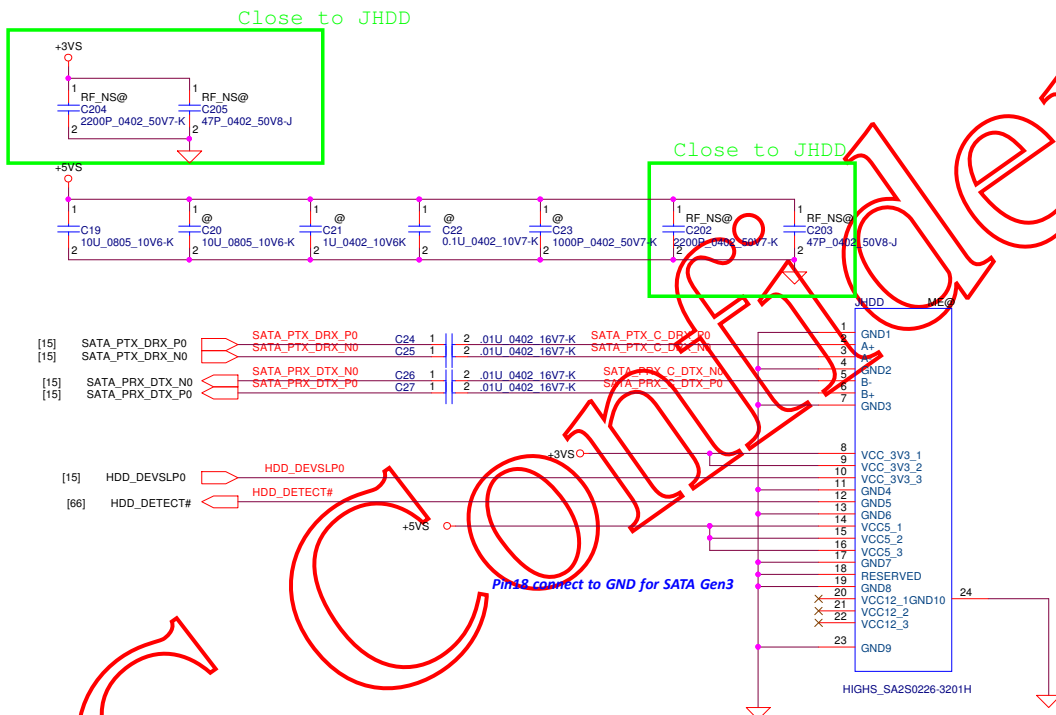

Security Classification	LC Future Center Secret Data		
Issued Date	2013/09/07	Deciphered Date	2014/09/07
THIS SHEET OF ENGINEERING DRAWING IS THE PROPRIETARY PROPERTY OF LC FUTURE CENTER, AND CONTAINS CONFIDENTIAL AND TRADE SECRET INFORMATION. THIS SHEET MAY NOT BE TRANSFERRED FROM THE CUSTODY OF THE COMPETENT DIVISION OF R&D DEPARTMENT EXCEPT AS AUTHORIZED BY LC FUTURE CENTER NEITHER THIS SHEET NOR THE INFORMATION IT CONTAINS MAY BE USED BY OR DISCLOSED TO ANY THIRD PARTY WITHOUT PRIOR WRITTEN CONSENT OF LC FUTURE CENTER.			

Title	SATA HDD/ODD		
Size	Document Number	Rev	1.0
Custom	BEAGO NM-A551		
Date:	Wednesday, August 05, 2015	Sheet	41 of 83



LCDVDD Circuit

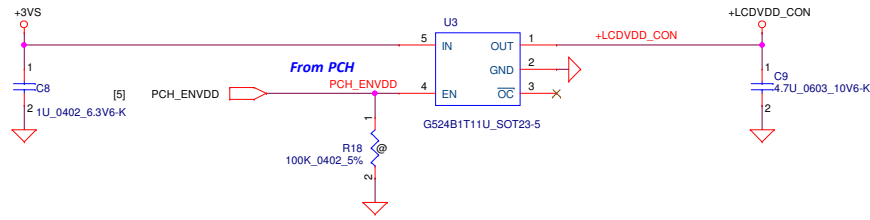

CMOS Camera

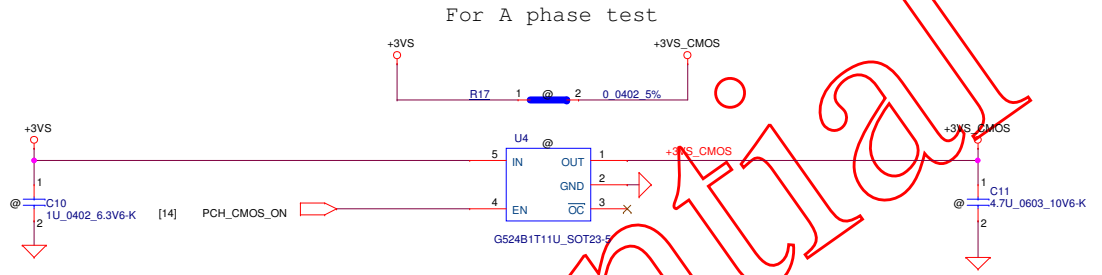

RF

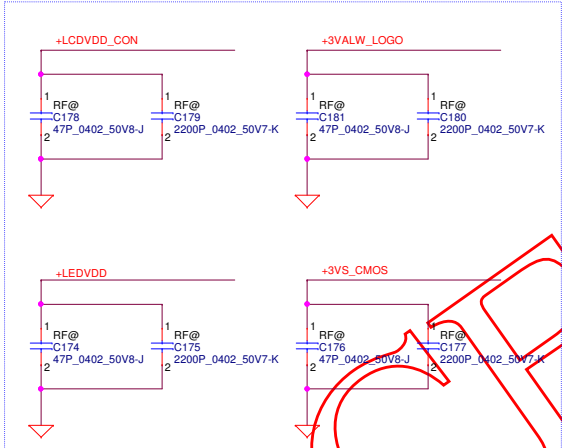

ESD request

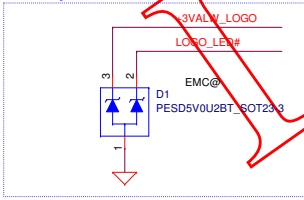

EMC request, Close to JLCD

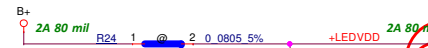
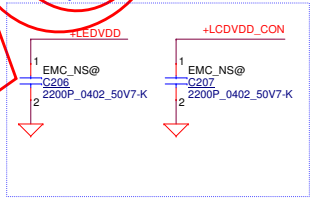

eDP CONN.

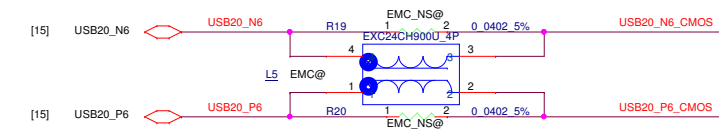
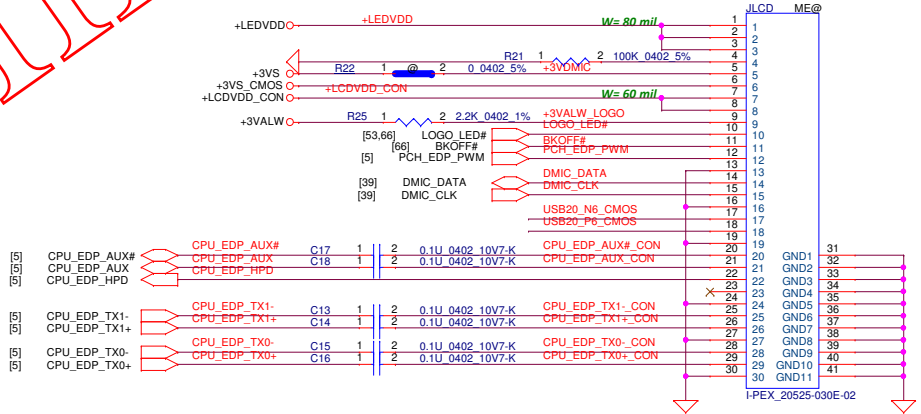

Security Classification	LC Future Center Secret Data		Title
Issued Date	2013/09/07	Deciphered Date	2014/09/07
THIS SHEET OF ENGINEERING DRAWING IS THE PROPRIETARY PROPERTY OF LC FUTURE CENTER, AND CONTAINS CONFIDENTIAL AND TRADE SECRET INFORMATION. THIS SHEET MAY NOT BE TRANSFERRED FROM THE CUSTODY OF THE COMPETENT DIVISION OF R&D DEPARTMENT EXCEPT AS AUTHORIZED BY LC FUTURE CENTER NEITHER THIS SHEET NOR THE INFORMATION IT CONTAINS MAY BE USED BY OR DISCLOSED TO ANY THIRD PARTY WITHOUT PRIOR WRITTEN CONSENT OF LC FUTURE CENTER.			
Size	Document Number	Rev	
Custom	BEAGO NM-A551	1.0	
Date:	Wednesday, August 05, 2015	Sheet	42 of 83

CONFIDENTIAL

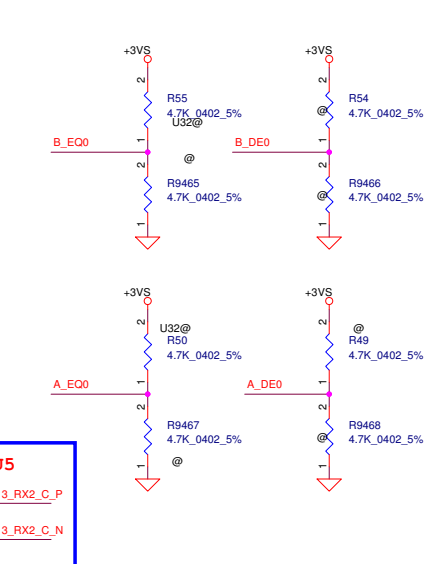
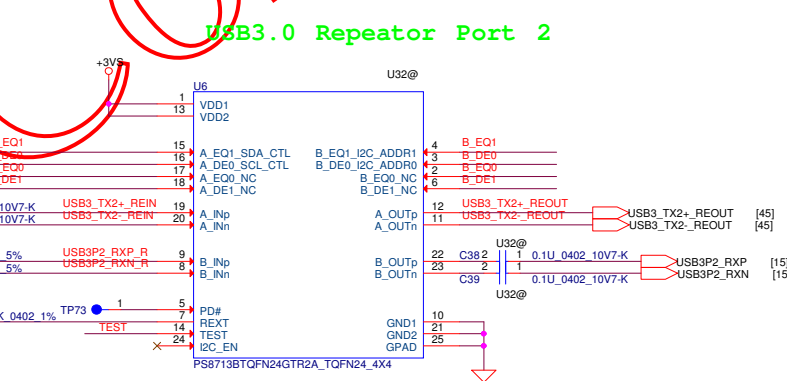
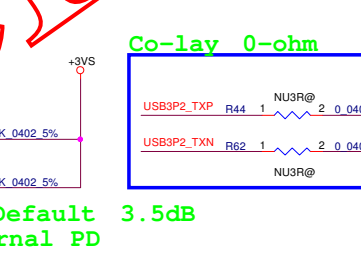
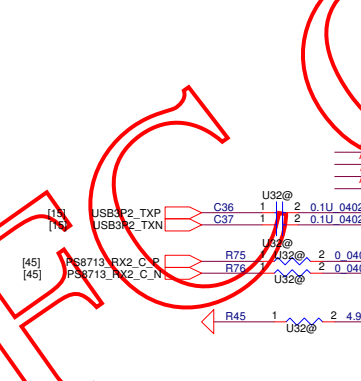
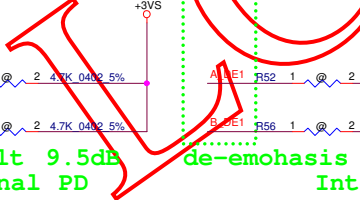
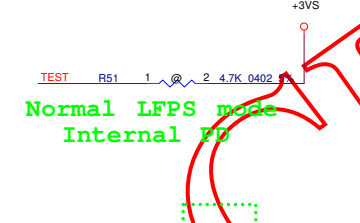
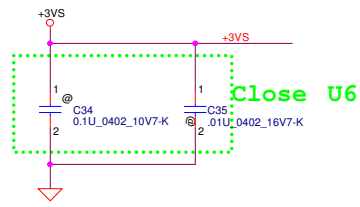
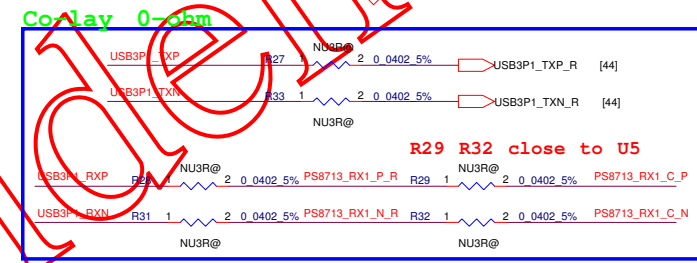
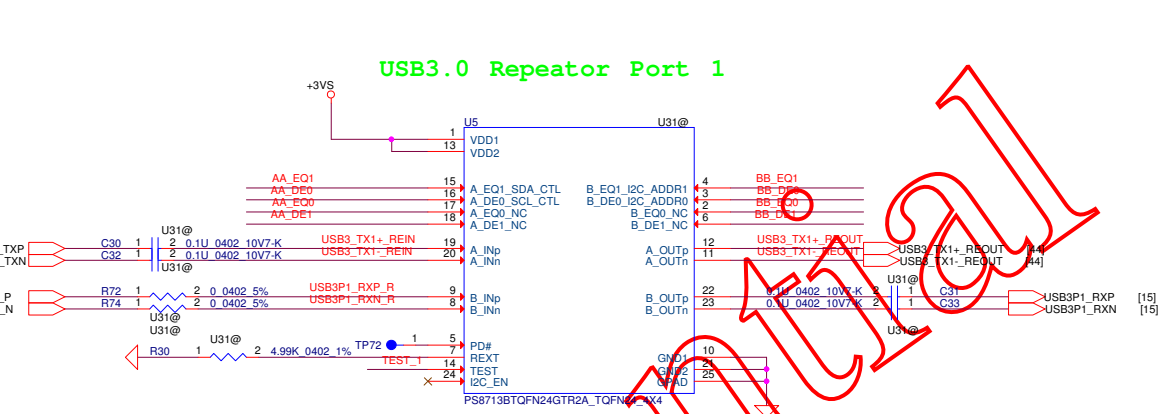
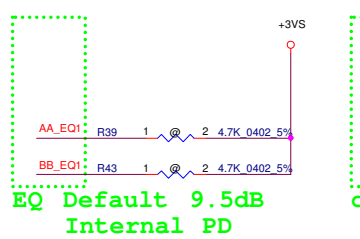
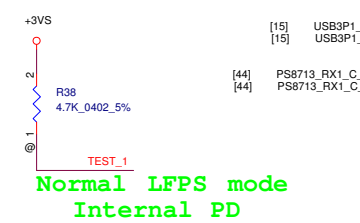
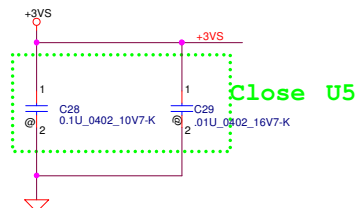
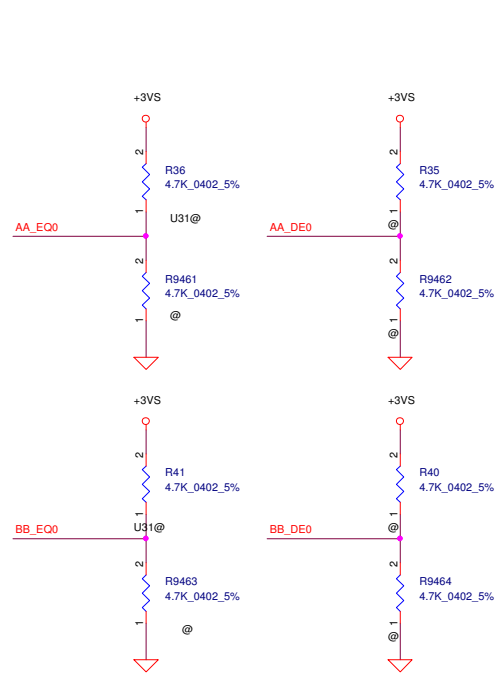

Security Classification	LC Future Center Secret Data		Title
Issued Date	2013/09/07	Deciphered Date	2014/09/07
THIS SHEET OF ENGINEERING DRAWING IS THE PROPRIETARY PROPERTY OF LC FUTURE CENTER, AND CONTAINS CONFIDENTIAL AND TRADE SECRET INFORMATION. THIS SHEET MAY NOT BE TRANSFERRED FROM THE CUSTODY OF THE COMPETENT DIVISION OF R&D DEPARTMENT EXCEPT AS AUTHORIZED BY LC FUTURE CENTER NEITHER THIS SHEET NOR THE INFORMATION IT CONTAINS MAY BE USED BY OR DISCLOSED TO ANY THIRD PARTY WITHOUT PRIOR WRITTEN CONSENT OF LC FUTURE CENTER.			
Size	Document Number	Rev	
Custom	BEA60-NM-A551	1.0	
Date:	Wednesday, August 05, 2015	Sheet	43 of 83



BEA60-NM-A551

Broadwell Connector (USB+S&C)

For 14" use(14" on board USB don't support S&C
 ,But 15" on board USB support S&C.S&C IC always on MB)

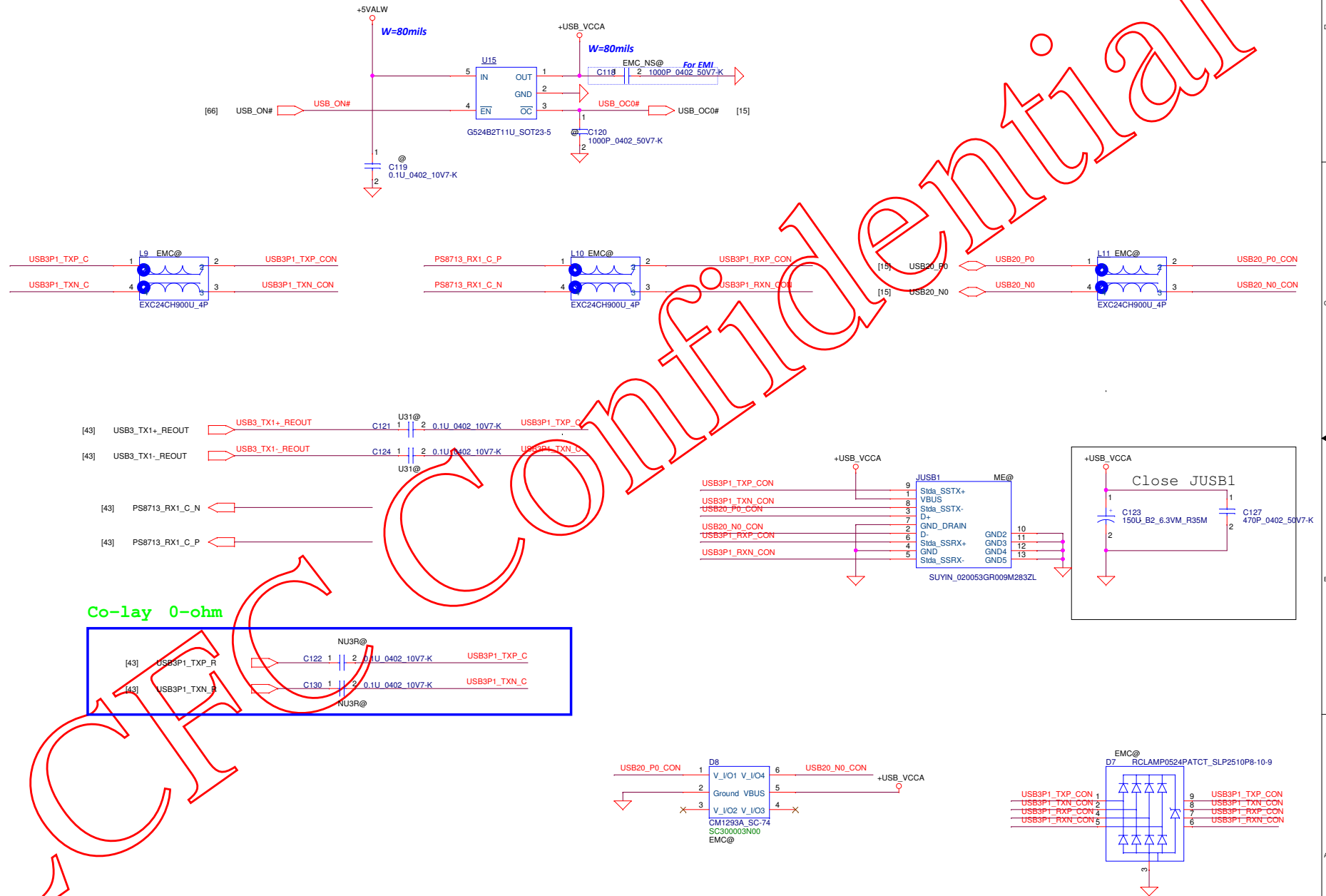

Co-lay 0-ohm

LCFC

Confidential

Security Classification				LC Future Center Secret Data		Title				
Issued Date	2013/09/07	Deciphered Date	2014/09/07	USB3 PORT1						
THIS SHEET OF ENGINEERING DRAWING IS THE PROPRIETARY PROPERTY OF LC FUTURE CENTER, AND CONTAINS CONFIDENTIAL AND TRADE SECRET INFORMATION. THIS SHEET MAY NOT BE TRANSFERRED FROM THE CUSTODY OF THE COMPETENT DIVISION OF R&D DEPARTMENT EXCEPT AS AUTHORIZED BY LC FUTURE CENTER NEITHER THIS SHEET NOR THE INFORMATION IT CONTAINS MAY BE USED BY OR DISCLOSED TO ANY THIRD PARTY WITHOUT PRIOR WRITTEN CONSENT OF LC FUTURE CENTER.								Size Custom	Document Number BE60 NM-A551	Rev 1.0
Date: Wednesday, August 05, 2015							Sheet		44 of 83	

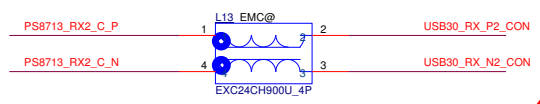
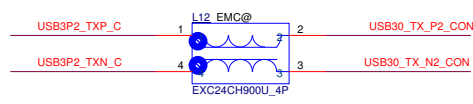

Co-layout L15 for EMI test

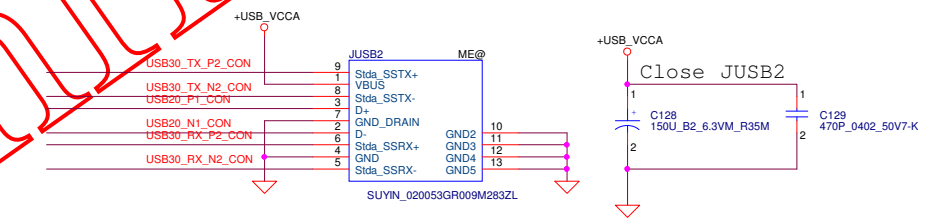
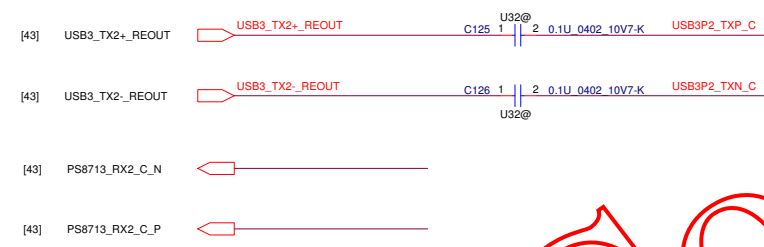
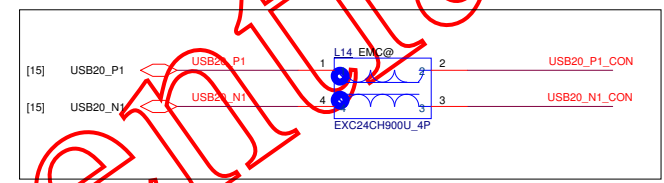

Co-lay 0-ohm

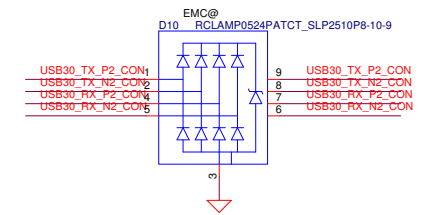
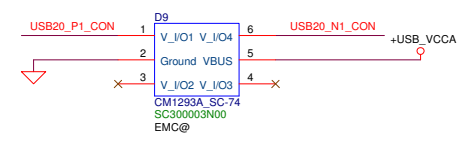
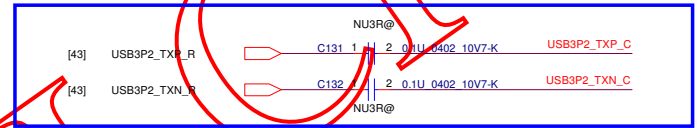

Confidential

Security Classification				LC Future Center Secret Data				Title		
Issued Date		2013/09/07		Deciphered Date		2014/09/07		USB3 PORT2		
THIS SHEET OF ENGINEERING DRAWING IS THE PROPRIETARY PROPERTY OF LC FUTURE CENTER, AND CONTAINS CONFIDENTIAL AND TRADE SECRET INFORMATION. THIS SHEET MAY NOT BE TRANSFERRED FROM THE CUSTODY OF THE COMPETENT DIVISION OF R&D DEPARTMENT EXCEPT AS AUTHORIZED BY LC FUTURE CENTER NEITHER THIS SHEET NOR THE INFORMATION IT CONTAINS MAY BE USED BY OR DISCLOSED TO ANY THIRD PARTY WITHOUT PRIOR WRITTEN CONSENT OF LC FUTURE CENTER.										
Date: Wednesday, August 21, 2014 11:41:11 AM							Page: 45 of 83		Size: Custom Document Number: BEAG0_NM-A551 Rev: 1.0	

LCFC Confidential

Security Classification	LC Future Center Secret Data		Title			
Issued Date	2013/09/07	Deciphered Date	2014/09/07		XXXX	
THIS SHEET OF ENGINEERING DRAWING IS THE PROPRIETARY PROPERTY OF LC FUTURE CENTER, AND CONTAINS CONFIDENTIAL AND TRADE SECRET INFORMATION. THIS SHEET MAY NOT BE TRANSFERRED FROM THE CUSTODY OF THE COMPETENT DIVISION OF R&D DEPARTMENT EXCEPT AS AUTHORIZED BY LC FUTURE CENTER NEITHER THIS SHEET NOR THE INFORMATION IT CONTAINS MAY BE USED BY OR DISCLOSED TO ANY THIRD PARTY WITHOUT PRIOR WRITTEN CONSENT OF LC FUTURE CENTER.				Size Custom	Document Number BE460 NM-A551	Rev 1.0
Date: Wednesday, August 05, 2015				Sheet	48	of 83

LCFC Confidential

Security Classification	LC Future Center Secret Data			Title	
Issued Date	2013/09/07	Deciphered Date	2014/09/07	XXXX	
<small>THIS SHEET OF ENGINEERING DRAWING IS THE PROPRIETARY PROPERTY OF LC FUTURE CENTER, AND CONTAINS CONFIDENTIAL AND TRADE SECRET INFORMATION. THIS SHEET MAY NOT BE TRANSFERRED FROM THE CUSTODY OF THE COMPETENT DIVISION OF R&D DEPARTMENT EXCEPT AS AUTHORIZED BY LC FUTURE CENTER NEITHER THIS SHEET NOR THE INFORMATION IT CONTAINS MAY BE USED BY OR DISCLOSED TO ANY THIRD PARTY WITHOUT PRIOR WRITTEN CONSENT OF LC FUTURE CENTER.</small>					Size Document Number Custom BE460 NM-A551
					Rev 1.0 Date: Wednesday, August 05, 2015 Sheet 47 of 83

LCFEC Confidential

Security Classification	LC Future Center Secret Data			Title	
Issued Date	2013/09/07	Deciphered Date	2014/09/07	XXXX	
<small>THIS SHEET OF ENGINEERING DRAWING IS THE PROPRIETARY PROPERTY OF LC FUTURE CENTER, AND CONTAINS CONFIDENTIAL AND TRADE SECRET INFORMATION. THIS SHEET MAY NOT BE TRANSFERRED FROM THE CUSTODY OF THE COMPETENT DIVISION OF R&D DEPARTMENT EXCEPT AS AUTHORIZED BY LC FUTURE CENTER NEITHER THIS SHEET NOR THE INFORMATION IT CONTAINS MAY BE USED BY OR DISCLOSED TO ANY THIRD PARTY WITHOUT PRIOR WRITTEN CONSENT OF LC FUTURE CENTER.</small>					Size Document Number Rev Custom BEAGO NM-A551 1.0
Date: Wednesday, August 05, 2015					Sheet 48 of 83

HDMI Repeater

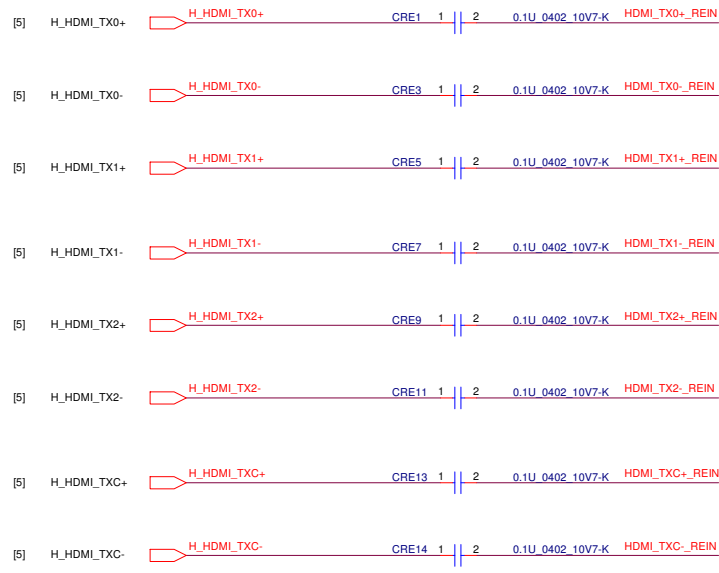

For 8407 use

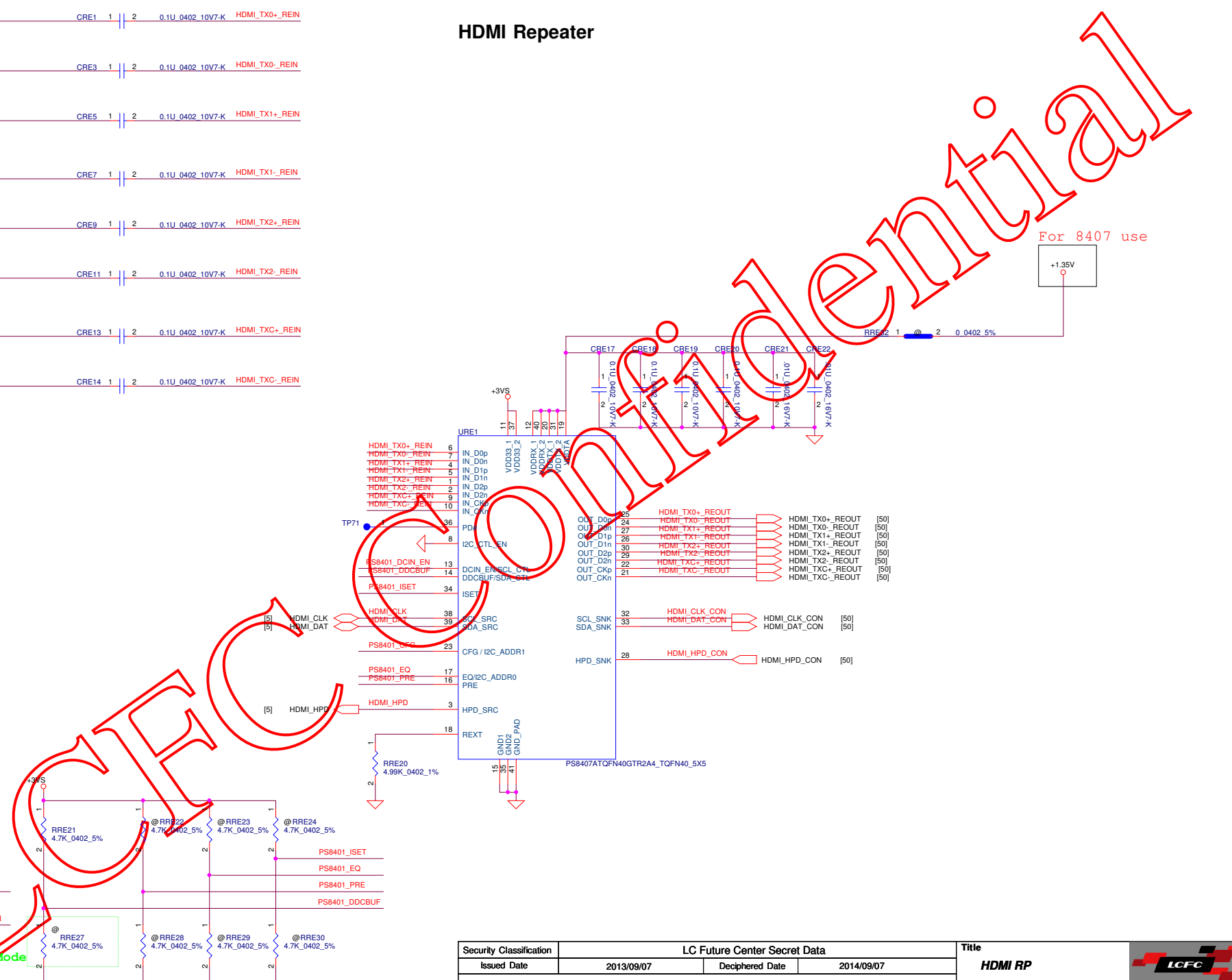
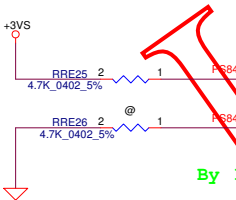
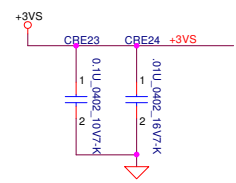
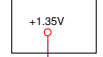

Security Classification		LC Future Center Secret Data		Title	
Issued Date	2013/09/07	Deciphered Date	2014/09/07	HDMI RP	
THIS SHEET OF ENGINEERING DRAWING IS THE PROPRIETARY PROPERTY OF LC FUTURE CENTER, AND CONTAINS CONFIDENTIAL AND TRADE SECRET INFORMATION. THIS SHEET MAY NOT BE TRANSFERRED FROM THE CUSTODY OF THE COMPETENT DIVISION OF R&D DEPARTMENT EXCEPT AS AUTHORIZED BY LC FUTURE CENTER NEITHER THIS SHEET NOR THE INFORMATION IT CONTAINS MAY BE USED BY OR DISCLOSED TO ANY THIRD PARTY WITHOUT PRIOR WRITTEN CONSENT OF LC FUTURE CENTER.					
Size	Document Number	BEAGO NM-A551		Rev	1.0
Date:	Wednesday, August 05, 2015	Sheet	49	of	83



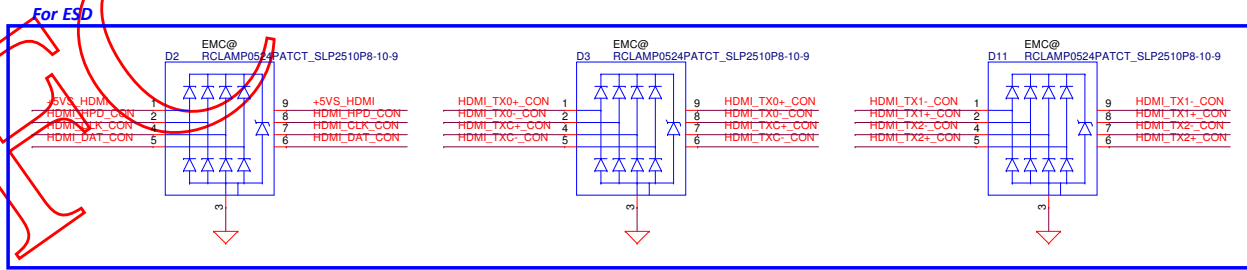
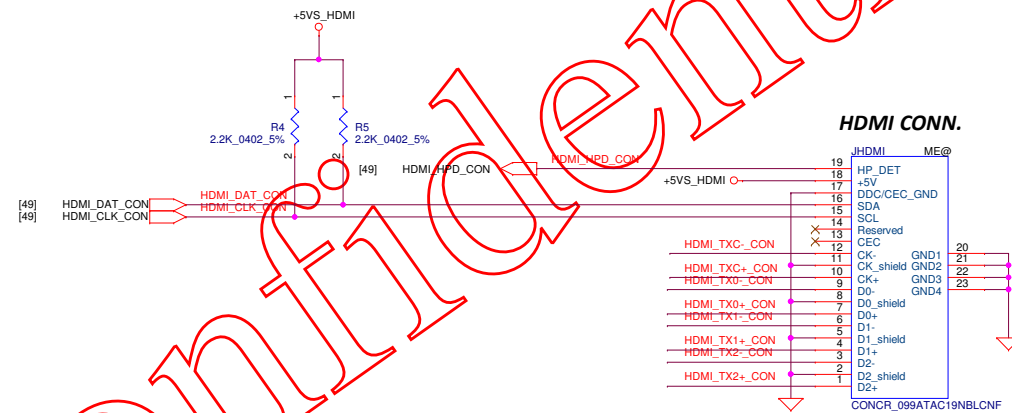
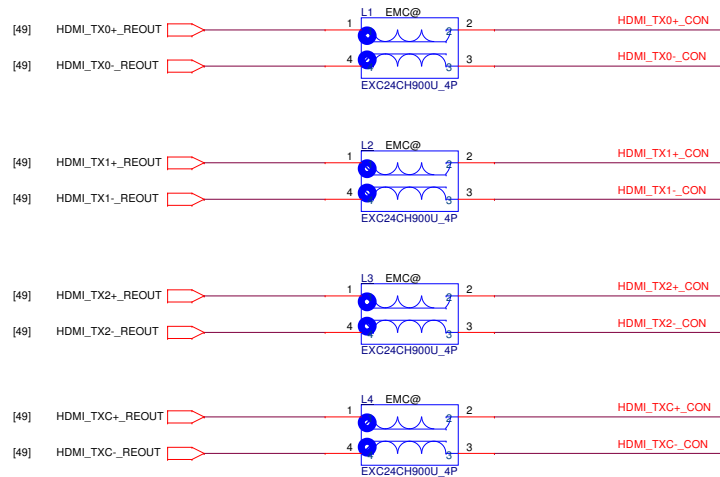
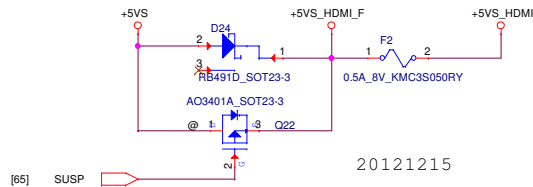

LCFC

Confidential

Security Classification		LC Future Center Secret Data		Title	
Issued Date	2013/09/07	Deciphered Date	2014/09/07	HDMI CONN.	
THIS SHEET OF ENGINEERING DRAWING IS THE PROPRIETARY PROPERTY OF LC FUTURE CENTER, AND CONTAINS CONFIDENTIAL AND TRADE SECRET INFORMATION. THIS SHEET MAY NOT BE TRANSFERRED FROM THE CUSTODY OF THE COMPETENT DIVISION OF R&D DEPARTMENT EXCEPT AS AUTHORIZED BY LC FUTURE CENTER NEITHER THIS SHEET NOR THE INFORMATION IT CONTAINS MAY BE USED BY OR DISCLOSED TO ANY THIRD PARTY WITHOUT PRIOR WRITTEN CONSENT OF LC FUTURE CENTER.				Size	Rev
				Custom	1.0
				BE460 NM-A551	
				Date:	Wednesday, August 05, 2015 Sheet 50 of 83

VPRO SKU :

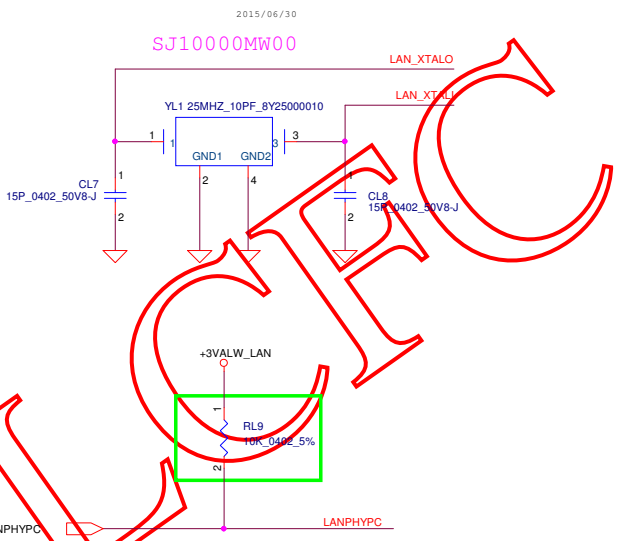
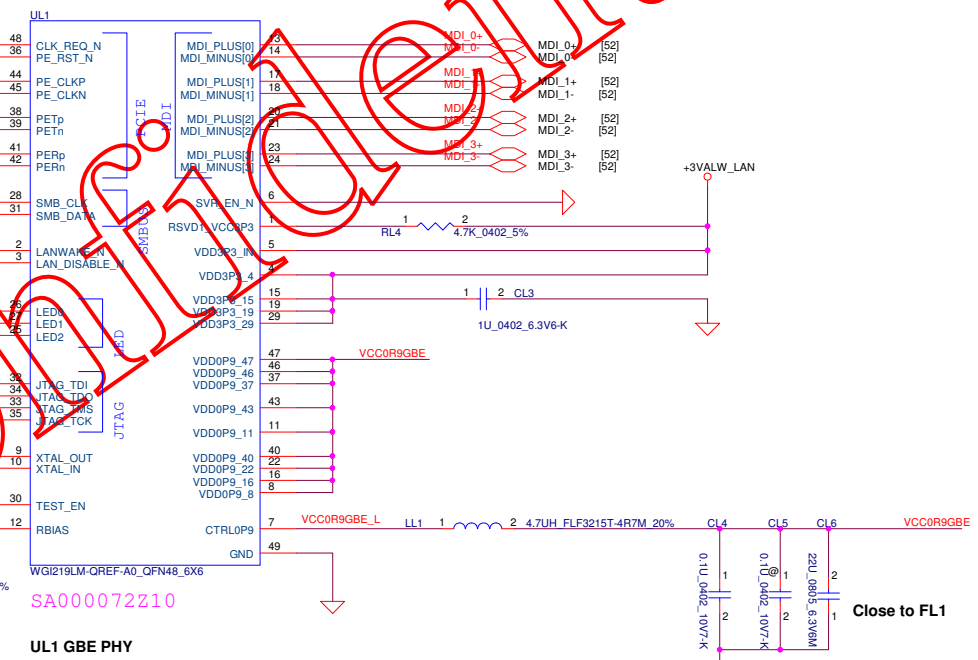
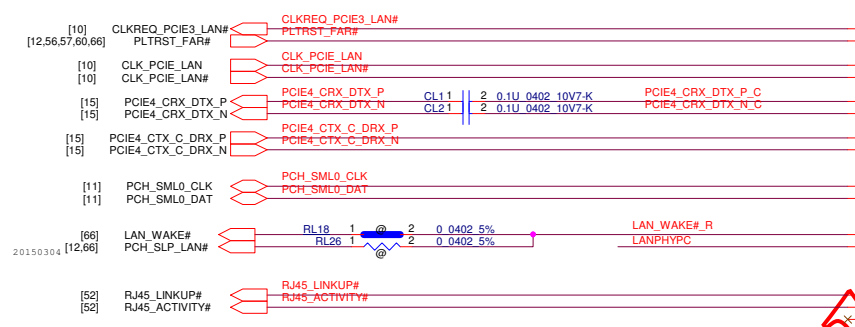
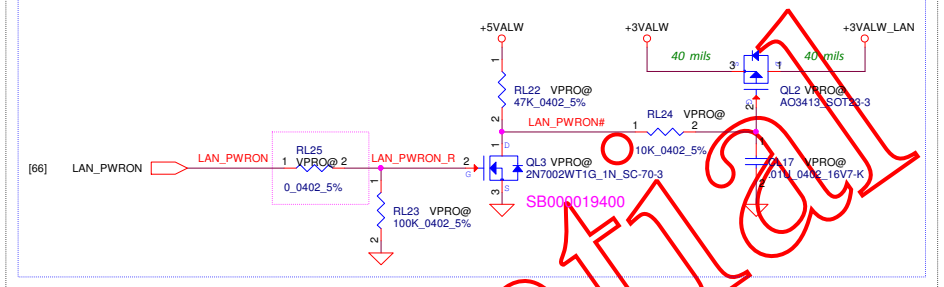

UL1 GBE PHY

vPro Model	Non-vPro Model
WG1219LM	WG1219V
SA000073000	SA000072Z10 SA000072Z20

ST-1_SWG_SDV-SWG_EC062
Add vPro/Non-vPro table.

When use Native function, intel recommend pull high 10K ohm
This part is un-mount in Sting.

CONFIDENTIAL

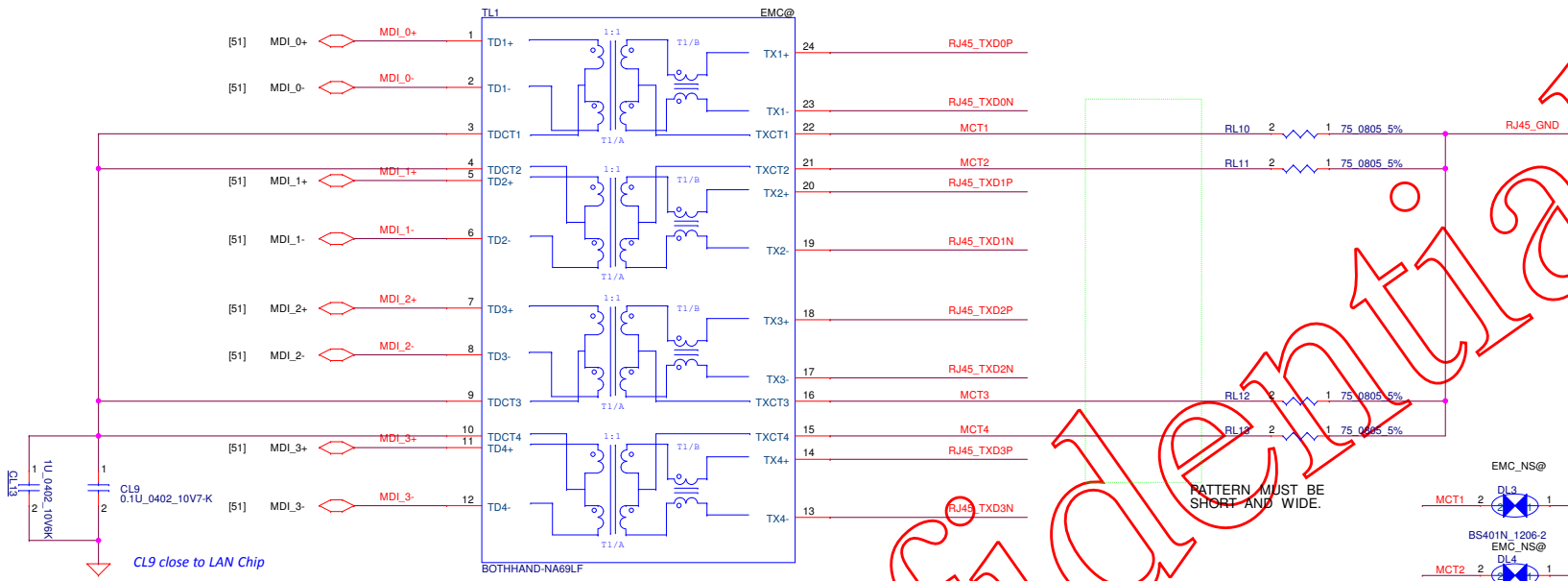

PATTERN MUST BE SHORT AND WIDE.

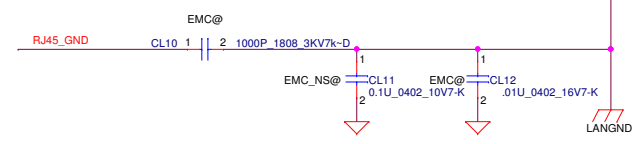
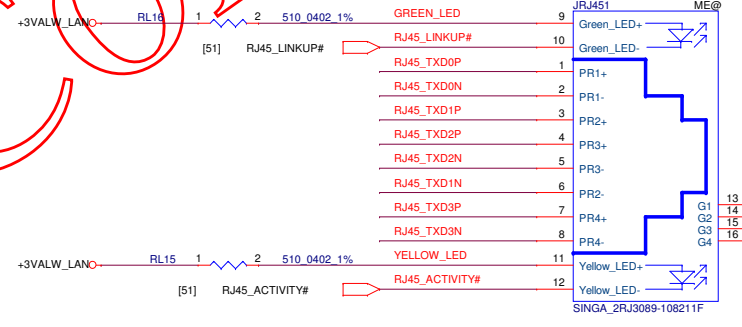
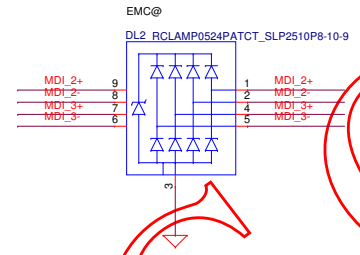
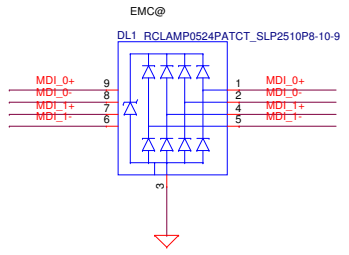
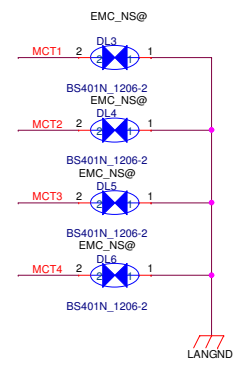

Security Classification				LC Future Center Secret Data				Title			
Issued Date	2013/09/07	Deciphered Date	2014/09/07	RJ45 CONN.				Size	Document Number		
THIS SHEET OF ENGINEERING DRAWING IS THE PROPRIETARY PROPERTY OF LC FUTURE CENTER, AND CONTAINS CONFIDENTIAL AND TRADE SECRET INFORMATION. THIS SHEET MAY NOT BE TRANSFERRED FROM THE CUSTODY OF THE COMPETENT DIVISION OF R&D DEPARTMENT EXCEPT AS AUTHORIZED BY LC FUTURE CENTER NEITHER THIS SHEET NOR THE INFORMATION IT CONTAINS MAY BE USED BY OR DISCLOSED TO ANY THIRD PARTY WITHOUT PRIOR WRITTEN CONSENT OF LC FUTURE CENTER.				Date: Wednesday, August 05, 2015				Sheet	52	01	83

BEAGO NM-A551

Rev 1.0

Click Pad

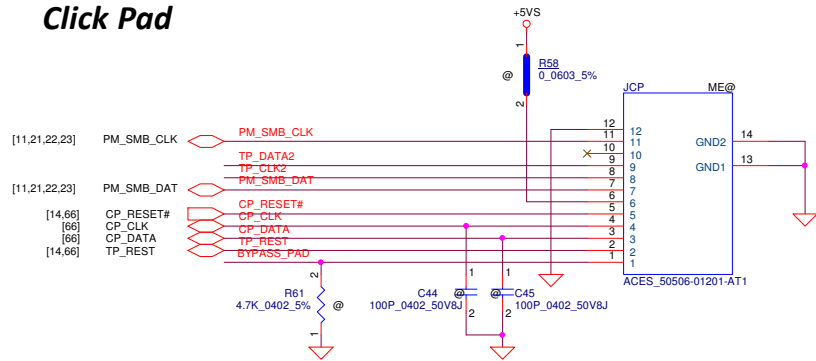

Track point

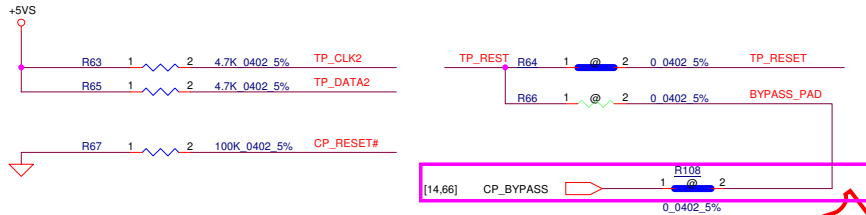
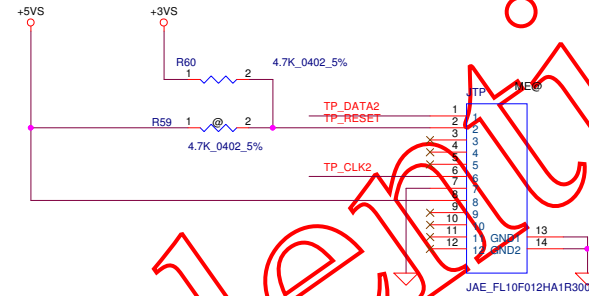

Only for Edge 14"

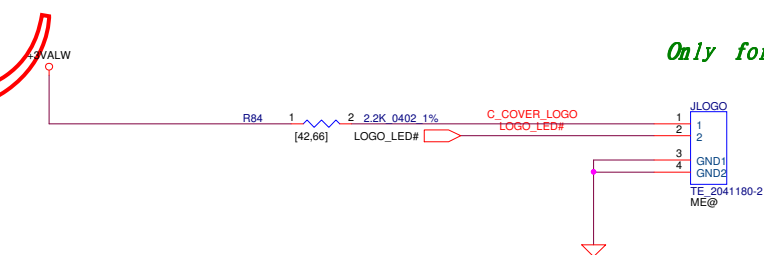

LCFC

Security Classification	LC Future Center Secret Data			Title	CP/TPOINTCONN.	
Issued Date	2013/09/07	Deciphered Date	2014/09/07	Size	Document Number	Rev
THIS SHEET OF ENGINEERING DRAWING IS THE PROPRIETARY PROPERTY OF LC FUTURE CENTER, AND CONTAINS CONFIDENTIAL AND TRADE SECRET INFORMATION. THIS SHEET MAY NOT BE TRANSFERRED FROM THE CUSTODY OF THE COMPETENT DIVISION OF R&D DEPARTMENT EXCEPT AS AUTHORIZED BY LC FUTURE CENTER NEITHER THIS SHEET NOR THE INFORMATION IT CONTAINS MAY BE USED BY OR DISCLOSED TO ANY THIRD PARTY WITHOUT PRIOR WRITTEN CONSENT OF LC FUTURE CENTER.				Custom	BEAGO NM-A551	1.0
				Date:	Wednesday, August 05, 2015	Sheet 53 of 83

FAN CONN.

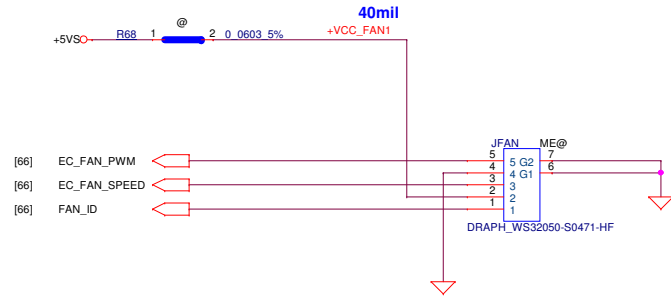

PWR BTN/LID SW CONN.

For 14" on board
For 15" on Sub/B

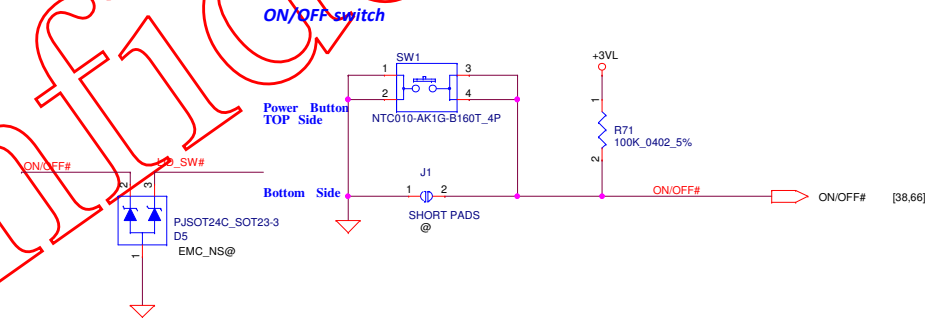

Lid Switch

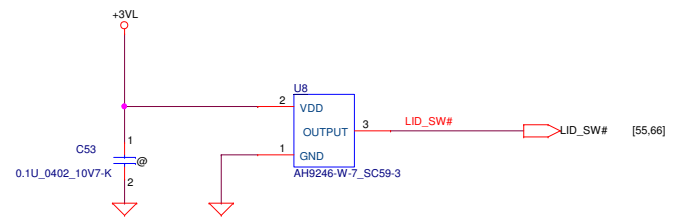

FingerPrint CONN.

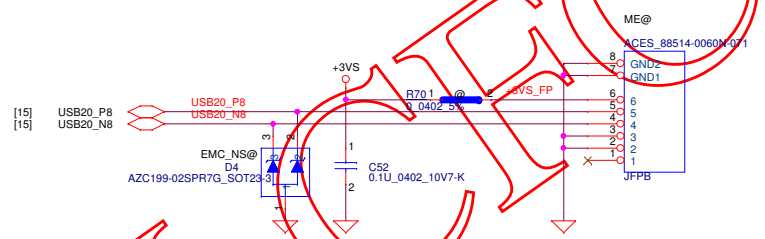

Security Classification		LC Future Center Secret Data		Title	
Issued Date	2013/09/07	Deciphered Date	2014/09/07	PBTN/LID/FP/FAN CONN.	
THIS SHEET OF ENGINEERING DRAWING IS THE PROPRIETARY PROPERTY OF LC FUTURE CENTER, AND CONTAINS CONFIDENTIAL AND TRADE SECRET INFORMATION. THIS SHEET MAY NOT BE TRANSFERRED FROM THE CUSTODY OF THE COMPETENT DIVISION OF R&D DEPARTMENT EXCEPT AS AUTHORIZED BY LC FUTURE CENTER NEITHER THIS SHEET NOR THE INFORMATION IT CONTAINS MAY BE USED BY OR DISCLOSED TO ANY THIRD PARTY WITHOUT PRIOR WRITTEN CONSENT OF LC FUTURE CENTER.				Size Custom	Document Number BEAGO NM-A551
				Date:	Wednesday, August 05, 2015
				Sheet	54 of 83
				Rev	1.0

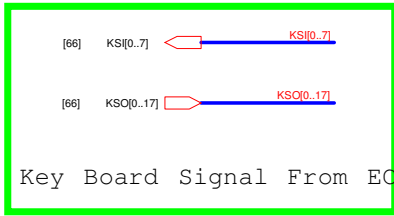

Keyboard CONN.(14")

Touch Panel CONN. For 14"

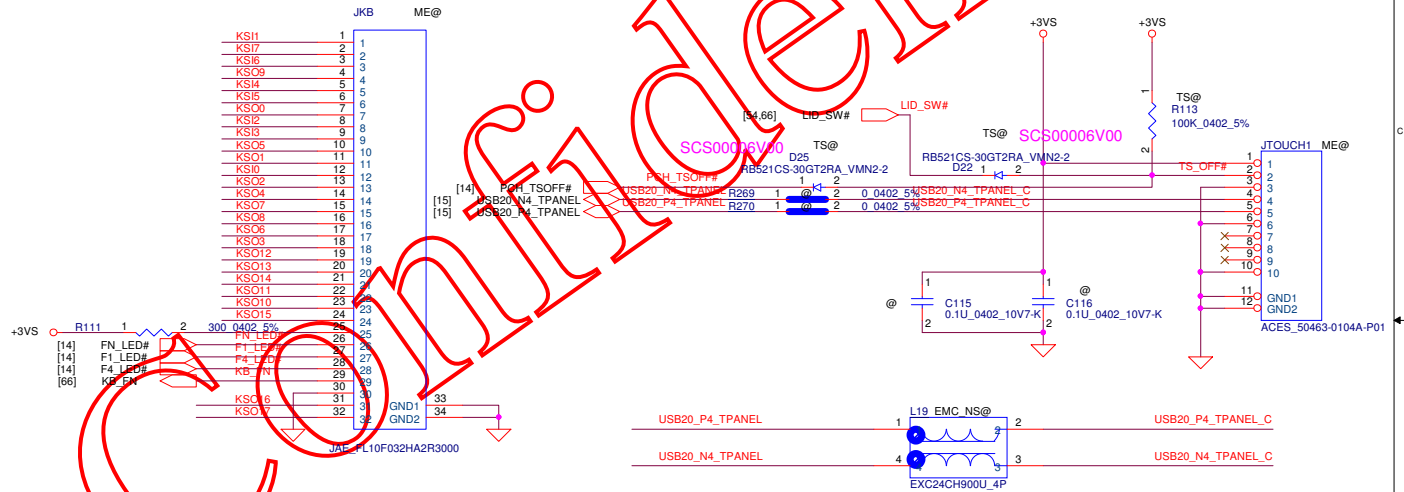
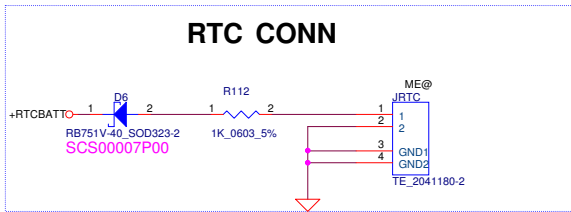

LCFC

Security Classification	LC Future Center Secret Data	
Issued Date	2013/09/07	Deciphered Date
		2014/09/07

Title	
KB/RTC/TOUCH PAN CONN.	

THIS SHEET OF ENGINEERING DRAWING IS THE PROPRIETARY PROPERTY OF LC FUTURE CENTER, AND CONTAINS CONFIDENTIAL AND TRADE SECRET INFORMATION. THIS SHEET MAY NOT BE TRANSFERRED FROM THE CUSTODY OF THE COMPETENT DIVISION OF R&D DEPARTMENT EXCEPT AS AUTHORIZED BY LC FUTURE CENTER NEITHER THIS SHEET NOR THE INFORMATION IT CONTAINS MAY BE USED BY OR DISCLOSED TO ANY THIRD PARTY WITHOUT PRIOR WRITTEN CONSENT OF LC FUTURE CENTER.

Size	Document	Number	Rev
Custom			1.0

Date: Wednesday, August 05, 2015 | Sheet 55 of 83

TYPE-A NGFF CCARD FOR WLAN

3.2H CONNECTOR

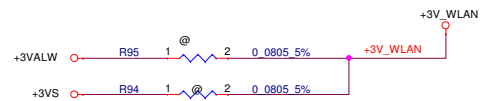

RF

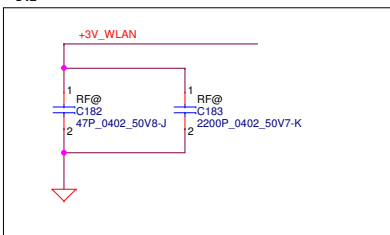

Close to Conn.

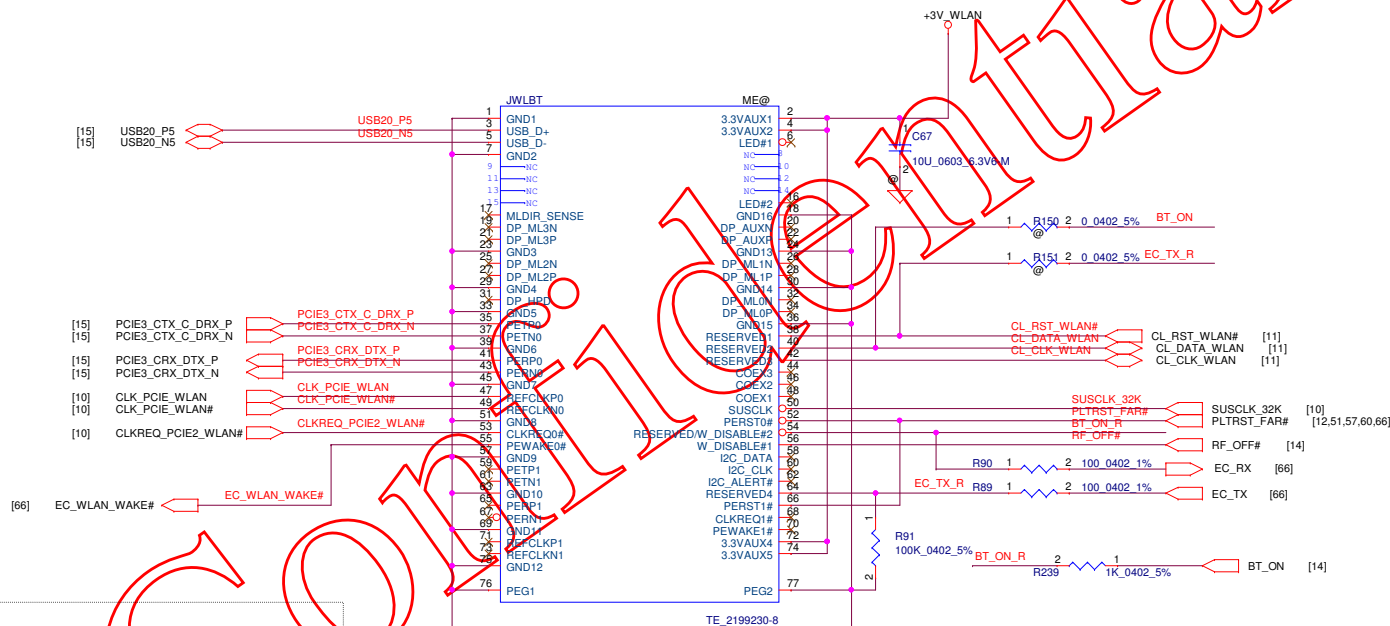
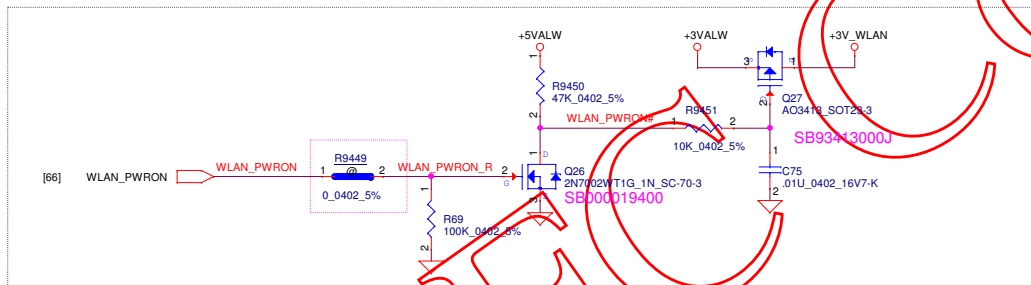

LOCH

Security Classification	LC Future Center Secret Data		Title
Issued Date	2013/09/07	Deciphered Date	2014/09/07
THIS SHEET OF ENGINEERING DRAWING IS THE PROPRIETARY PROPERTY OF LC FUTURE CENTER, AND CONTAINS CONFIDENTIAL AND TRADE SECRET INFORMATION. THIS SHEET MAY NOT BE TRANSFERRED FROM THE CUSTODY OF THE COMPETENT DIVISION OF R&D DEPARTMENT EXCEPT AS AUTHORIZED BY LC FUTURE CENTER. NEITHER THIS SHEET NOR THE INFORMATION IT CONTAINS MAY BE USED BY OR DISCLOSED TO ANY THIRD PARTY WITHOUT PRIOR WRITTEN CONSENT OF LC FUTURE CENTER.			Size Custom
			Document Number BE460 NW-A551
			Rev 1.0
			Date: Wednesday, August 05, 2015 Sheet 56 of 83

For 14" S&C IC on MB) S&C port on SUB/B

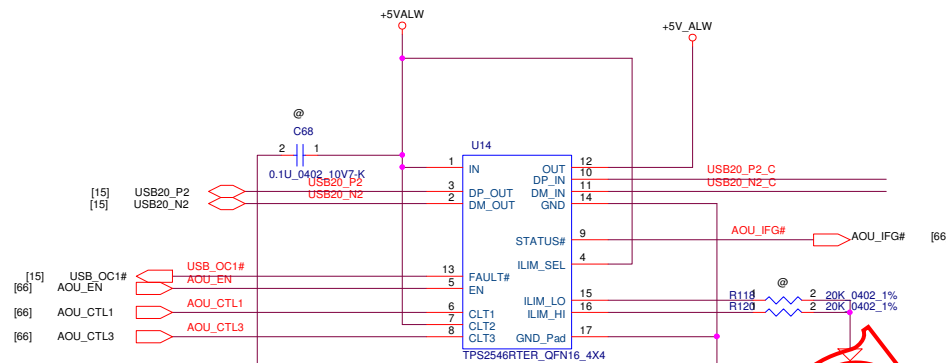

TI TPS2546

CLT1	CLT2	CLT3	ILIM_SEL	MOD
0	0	0	X	DCH OUT held low
1	1	1	1	CDP Data Connected and Port Power Mgt. Function Active
1	1	1	0	SDP2 Data Connected
1	1	0	X	SDP1 Data Connected
0	1	0	X	SDP1 Data Connected
1	0	0	X	DCP_Short Device Forced to stay in DCP Bc 1.2 charging mode
1	0	1	X	DCP_Divider Device Forced to stay in DCP Divider 1 Charging Mode
0	1	1	X	DCP_Auto Data Disconnected and Port Power Mgt. Function Active
0	0	1	X	DCP_Auto Data Disconnected and Power Wake Function Active

USB_OC5# to MCP
 AOU_EN to EC
 AOU_CTL1 to EC
 AOU_CTL3 to EC
 AOU_IFG# to EC

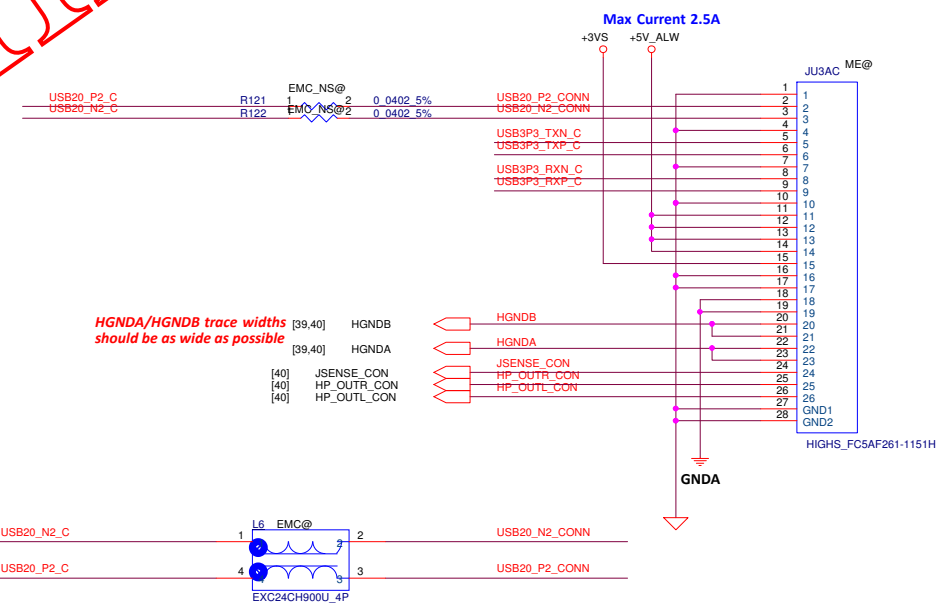
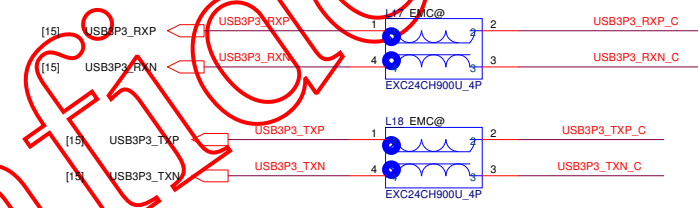
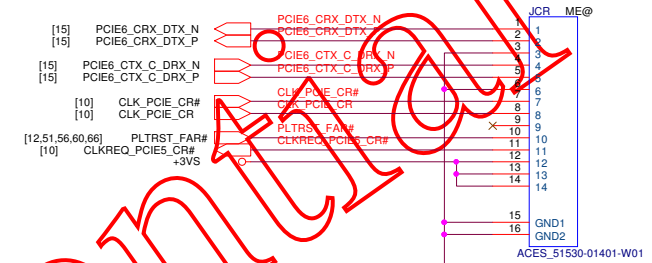

HGND A/HGND B trace widths should be as wide as possible [39,40] HGND B [39,40] HGND A [40] JSENSE_CON [40] HP_OUTR_CON [40] HP_OUTL_CON

LCFEC Confidential

Security Classification	LC Future Center Secret Data			Title	XXXX		
Issued Date	2013/09/07	Deciphered Date	2014/09/07	Size	Custom		
THIS SHEET OF ENGINEERING DRAWING IS THE PROPRIETARY PROPERTY OF LC FUTURE CENTER, AND CONTAINS CONFIDENTIAL AND TRADE SECRET INFORMATION. THIS SHEET MAY NOT BE TRANSFERRED FROM THE CUSTODY OF THE COMPETENT DIVISION OF R&D DEPARTMENT EXCEPT AS AUTHORIZED BY LC FUTURE CENTER NEITHER THIS SHEET NOR THE INFORMATION IT CONTAINS MAY BE USED BY OR DISCLOSED TO ANY THIRD PARTY WITHOUT PRIOR WRITTEN CONSENT OF LC FUTURE CENTER.				Document Number	BE460 NM-A551	Rev	1.0
				Date:	Wednesday, August 05, 2015	Sheet	58 of 83

Thermal Sensor

Thermal Sensor placed near by VRAM

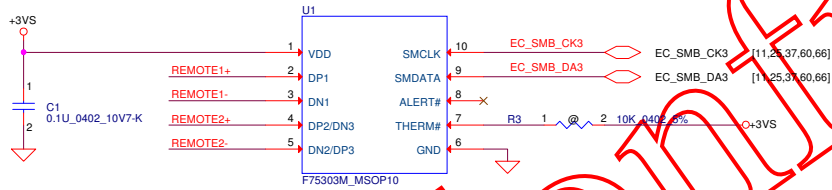

Close to U1

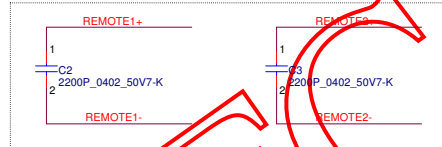

Under VRAM

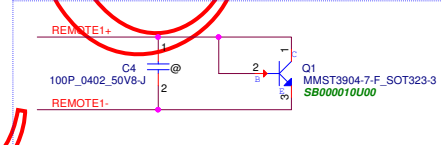

Close to +VCC_CORE

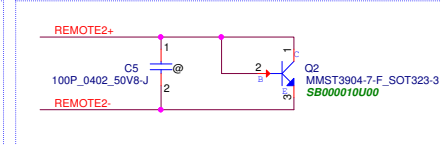

REMOTE2+/-:
Trace width/space:10/10 mil
Trace length:<8"

LCFC

Security Classification	LC Future Center Secret Data		Title	<p>THERMAL SENSOR</p>
Issued Date	2013/09/07	Deciphered Date	2014/09/07	
<p>THIS SHEET OF ENGINEERING DRAWING IS THE PROPRIETARY PROPERTY OF LC FUTURE CENTER, AND CONTAINS CONFIDENTIAL AND TRADE SECRET INFORMATION. THIS SHEET MAY NOT BE TRANSFERRED FROM THE CUSTODY OF THE COMPETENT DIVISION OF R&D DEPARTMENT EXCEPT AS AUTHORIZED BY LC FUTURE CENTER. NEITHER THIS SHEET NOR THE INFORMATION IT CONTAINS MAY BE USED BY OR DISCLOSED TO ANY THIRD PARTY WITHOUT PRIOR WRITTEN CONSENT OF LC FUTURE CENTER.</p>				Size Document Number Custom BE460 NW-A551 Rev 1.0
Date:	Wednesday, August 05, 2015	Sheet	59 of 83	

APS G-Sensor

TABLE

P/N	Mode Selection
H	I2C Mode
L	SPI Mode

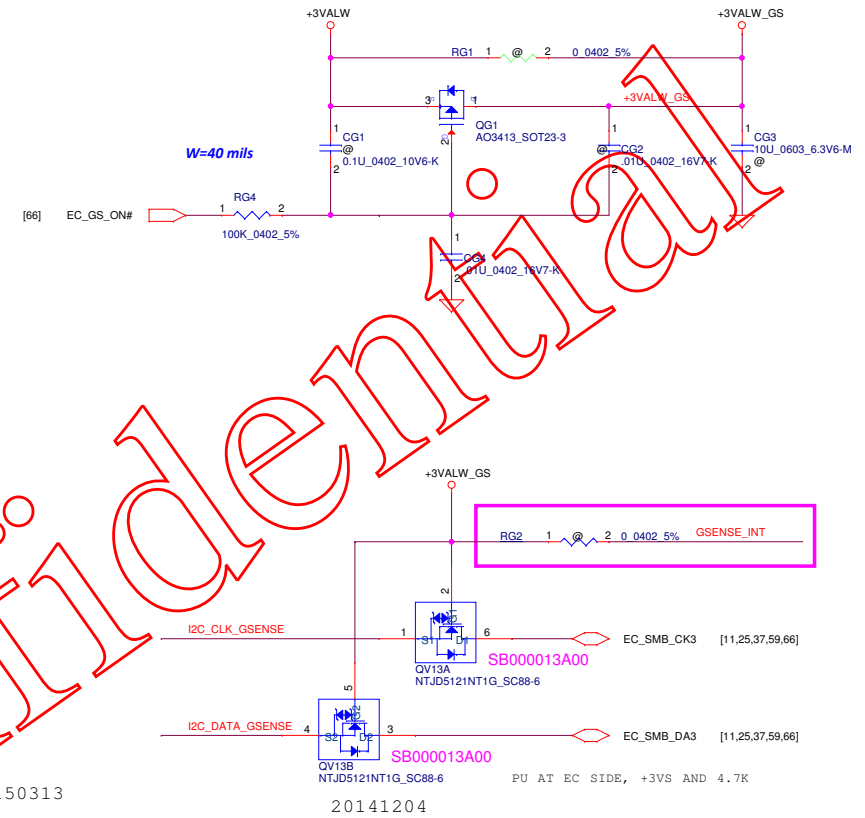
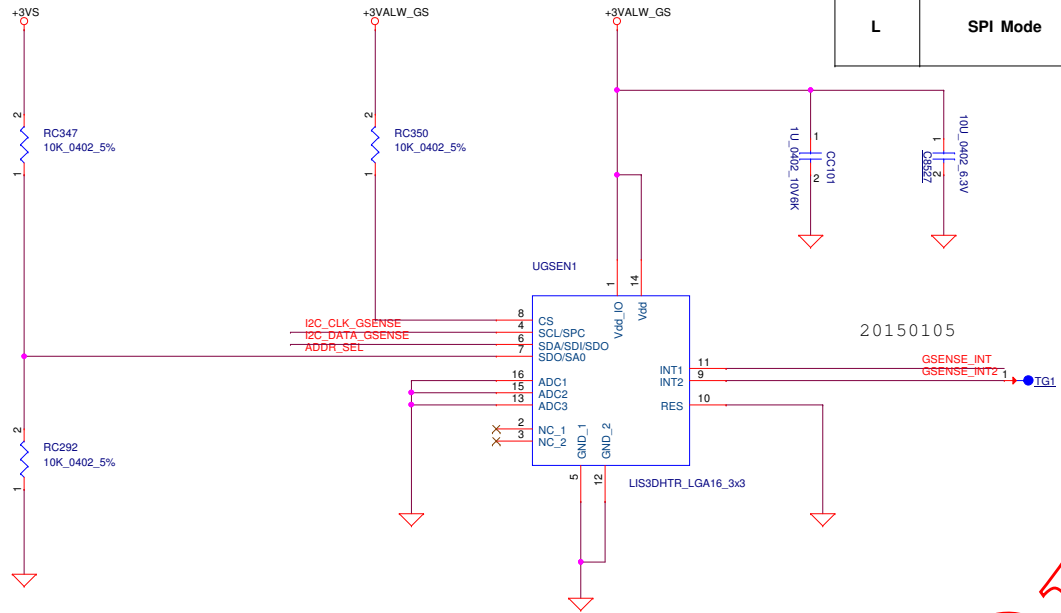

Only for UMA SKU

20141128

NOTE:
Place 0.1 uF capacitors as close as possible to the device power pins.

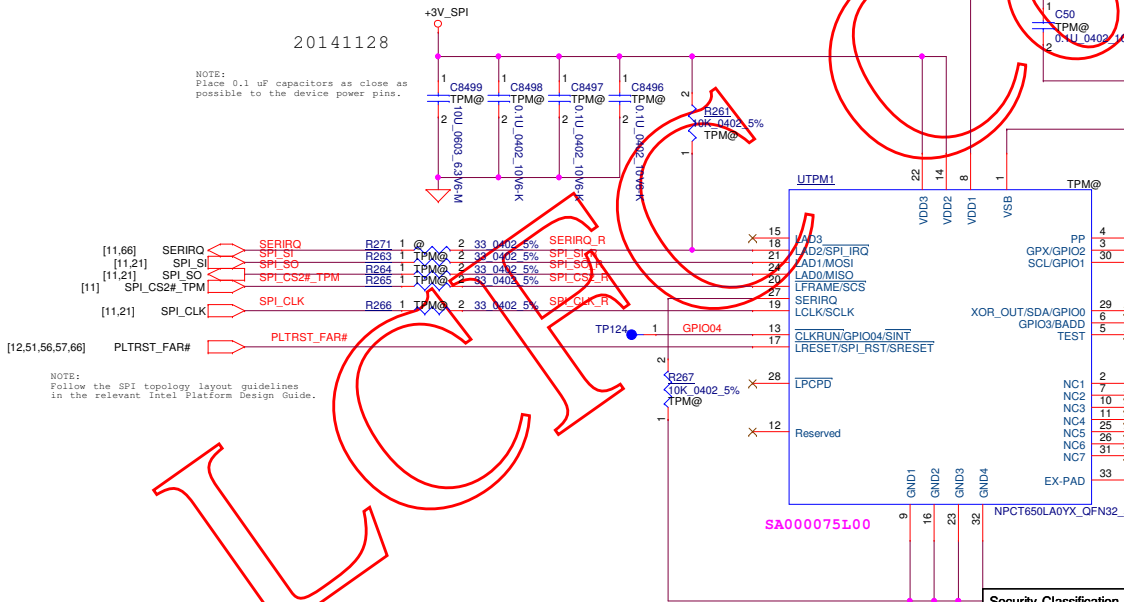

NOTE:
Follow the SPI topology layout guidelines in the relevant Intel Platform Design Guide.

TABLE

P/N	ADDR_SEL	Address
LIS3DH	H	32h (W) & 33h (R)
	L	30h (W) & 31h (R)
KX023-1025	H	3Eh (W) & 3Fh (R)
	L	3Ch (W) & 3Dh (R)

	Q29	R268	R273	R9456
New silicon NPCT650LBOYX	X	O	X	X
Current silicon NPCT650LA0YX	O	X	O	O

Security Classification	LC Future Center Secret Data	
Issued Date	2013/09/07	Deciphered Date
		2014/09/07

Title	
G SENSOR/TPM	

THIS SHEET OF ENGINEERING DRAWING IS THE PROPRIETARY PROPERTY OF LC FUTURE CENTER, AND CONTAINS CONFIDENTIAL AND TRADE SECRET INFORMATION. THIS SHEET MAY NOT BE TRANSFERRED FROM THE CUSTODY OF THE COMPETENT DIVISION OF R&D DEPARTMENT EXCEPT AS AUTHORIZED BY LC FUTURE CENTER NEITHER THIS SHEET NOR THE INFORMATION IT CONTAINS MAY BE USED BY OR DISCLOSED TO ANY THIRD PARTY WITHOUT PRIOR WRITTEN CONSENT OF LC FUTURE CENTER.

Size	Document Number	Rev
Custom	BEAGO-NM-A551	1.0

LCFEC Confidential

Security Classification	LC Future Center Secret Data		Title	
Issued Date	2013/09/07	Deciphered Date	2014/09/07	
<small>THIS SHEET OF ENGINEERING DRAWING IS THE PROPRIETARY PROPERTY OF LC FUTURE CENTER, AND CONTAINS CONFIDENTIAL AND TRADE SECRET INFORMATION. THIS SHEET MAY NOT BE TRANSFERRED FROM THE CUSTODY OF THE COMPETENT DIVISION OF R&D DEPARTMENT EXCEPT AS AUTHORIZED BY LC FUTURE CENTER NEITHER THIS SHEET NOR THE INFORMATION IT CONTAINS MAY BE USED BY OR DISCLOSED TO ANY THIRD PARTY WITHOUT PRIOR WRITTEN CONSENT OF LC FUTURE CENTER.</small>				Size: Custom Document Number: BE460 NM-A551 Date: Wednesday, August 05, 2015
				Rev: 1.0 Sheet: 61 of 83

LCFEC Confidential

Security Classification	LC Future Center Secret Data			Title		
Issued Date	2013/09/07	Deciphered Date	2014/09/07	XXXX		
<small>THIS SHEET OF ENGINEERING DRAWING IS THE PROPRIETARY PROPERTY OF LC FUTURE CENTER, AND CONTAINS CONFIDENTIAL AND TRADE SECRET INFORMATION. THIS SHEET MAY NOT BE TRANSFERRED FROM THE CUSTODY OF THE COMPETENT DIVISION OF R&D DEPARTMENT EXCEPT AS AUTHORIZED BY LC FUTURE CENTER. NEITHER THIS SHEET NOR THE INFORMATION IT CONTAINS MAY BE USED BY OR DISCLOSED TO ANY THIRD PARTY WITHOUT PRIOR WRITTEN CONSENT OF LC FUTURE CENTER.</small>					Size: Custom Document Number: BE460 NM-A551 Date: Wednesday, August 05, 2015 Sheet: 62 of 83	Rev: 1.0

LCFC Confidential

Security Classification	LC Future Center Secret Data			Title	XXXX	
Issued Date	2013/09/07	Deciphered Date	2014/09/07			
<small>THIS SHEET OF ENGINEERING DRAWING IS THE PROPRIETARY PROPERTY OF LC FUTURE CENTER, AND CONTAINS CONFIDENTIAL AND TRADE SECRET INFORMATION. THIS SHEET MAY NOT BE TRANSFERRED FROM THE CUSTODY OF THE COMPETENT DIVISION OF R&D DEPARTMENT EXCEPT AS AUTHORIZED BY LC FUTURE CENTER. NEITHER THIS SHEET NOR THE INFORMATION IT CONTAINS MAY BE USED BY OR DISCLOSED TO ANY THIRD PARTY WITHOUT PRIOR WRITTEN CONSENT OF LC FUTURE CENTER.</small>				Size	Document Number	Rev
				Custom	BE460 NW-A551	1.0
				Date:	Wednesday, August 05, 2015	Sheet 63 of 83

+1VALW to +VCC_IO_AP

3 A

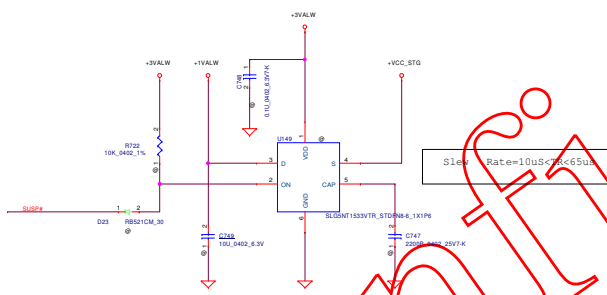
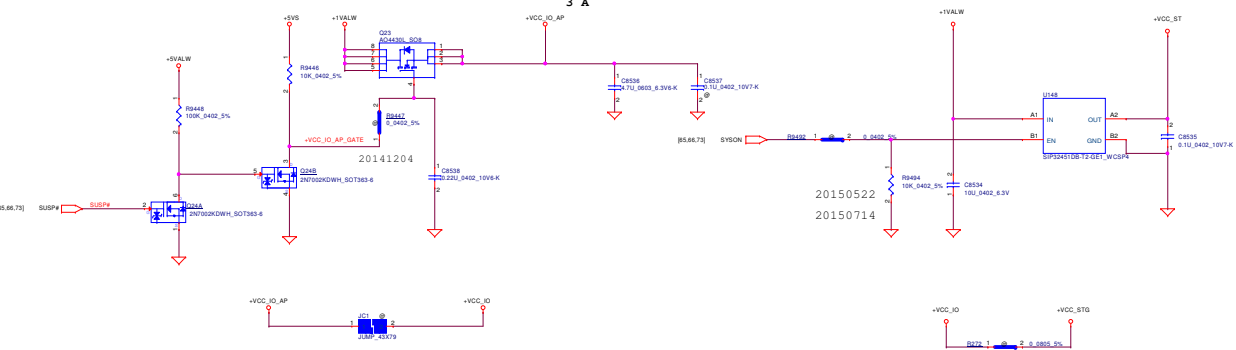

LCFEC

Confidential

Security Classification	LC Future Center Secret Data		Title
Issued Date	20130907	Declassified Date	20140907
			XXXX
<small>THIS SHEET OF ENGINEERING DRAWING IS THE PROPRIETARY PROPERTY OF LC FUTURE CENTER AND CONTAINS CONFIDENTIAL AND UNCLASSIFIED INFORMATION. THIS SHEET MAY NOT BE REPRODUCED FROM THE CUSTODY OF THE COMMANDER AVNOC OF PMO WITHOUT EXPRESS PERMISSION. THIS SHEET MAY NOT BE REPRODUCED FROM THE CUSTODY OF THE COMMANDER AVNOC OF PMO WITHOUT EXPRESS PERMISSION. THIS SHEET MAY NOT BE REPRODUCED FROM THE CUSTODY OF THE COMMANDER AVNOC OF PMO WITHOUT EXPRESS PERMISSION.</small>			Document Number BA600-NW-AS51
Scale	0	Sheet	14
Drawn	W. J. ...	Checked	...

Load Switch
+5VALW To +5VS
+3VALW To +3VS

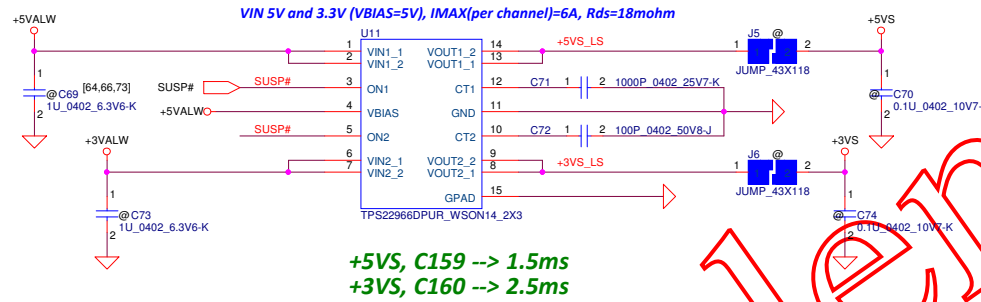

+3VALW to +3V_DDR

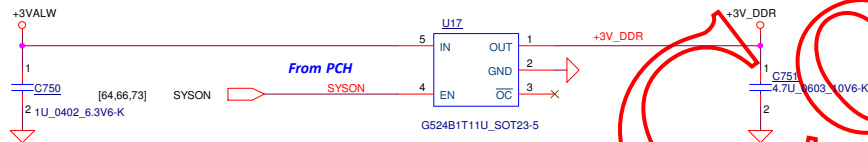

SUSP# to SUSP

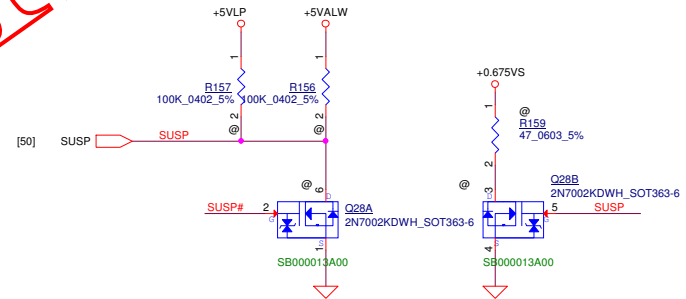

LCFEC

Security Classification	LC Future Center Secret Data		Title
Issued Date	2013/09/07	Deciphered Date	2014/09/07
<small>THIS SHEET OF ENGINEERING DRAWING IS THE PROPRIETARY PROPERTY OF LC FUTURE CENTER, AND CONTAINS CONFIDENTIAL AND TRADE SECRET INFORMATION. THIS SHEET MAY NOT BE TRANSFERRED FROM THE CUSTODY OF THE COMPETENT DIVISION OF R&D DEPARTMENT EXCEPT AS AUTHORIZED BY LC FUTURE CENTER. NEITHER THIS SHEET NOR THE INFORMATION IT CONTAINS MAY BE USED BY OR DISCLOSED TO ANY THIRD PARTY WITHOUT PRIOR WRITTEN CONSENT OF LC FUTURE CENTER.</small>			
Size	Document Number	Rev	
Custom	BE460 NW-A551	1.0	
Date:	Wednesday, August 06, 2015	Sheet	65 of 83

Screw Hole

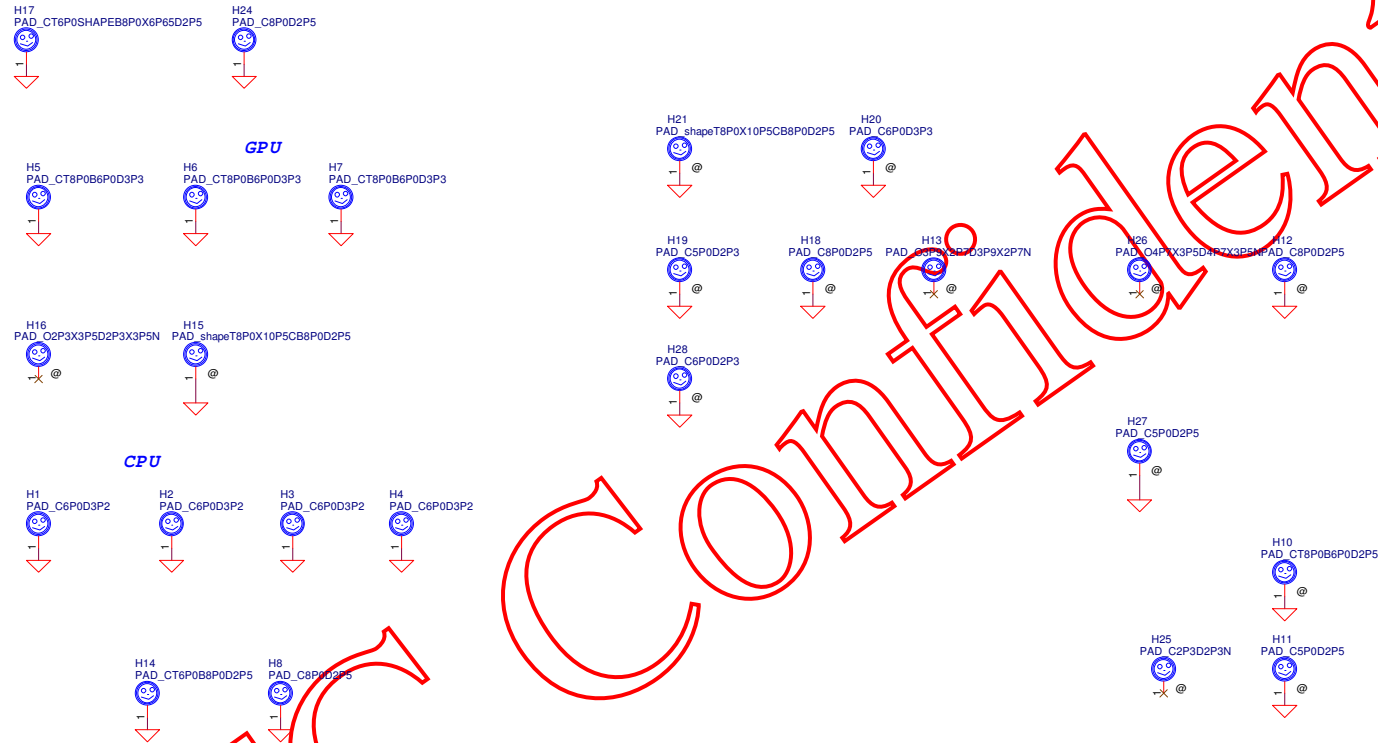

LCFC

Confidential

PCB Fedical Mark PAD



Security Classification	LC Future Center Secret Data	
Issued Date	2013/09/07	Deciphered Date 2014/09/07

THIS SHEET OF ENGINEERING DRAWING IS THE PROPRIETARY PROPERTY OF LC FUTURE CENTER, AND CONTAINS CONFIDENTIAL AND TRADE SECRET INFORMATION. THIS SHEET MAY NOT BE TRANSFERRED FROM THE CUSTODY OF THE COMPETENT DIVISION OF R&D DEPARTMENT EXCEPT AS AUTHORIZED BY LC FUTURE CENTER NEITHER THIS SHEET NOR THE INFORMATION IT CONTAINS MAY BE USED BY OR DISCLOSED TO ANY THIRD PARTY WITHOUT PRIOR WRITTEN CONSENT OF LC FUTURE CENTER.

Title	PLM/SCREW HOLE
-------	----------------



Size	Document Number	Rev
Custom	BE460 NM-A551	1.0
Date:	Wednesday, August 05, 2015	Sheet 67 of 83

LCFC Confidential

Security Classification	LC Future Center Secret Data			Title	
Issued Date	2013/09/07	Deciphered Date	2014/09/07	XXXX	
<small>THIS SHEET OF ENGINEERING DRAWING IS THE PROPRIETARY PROPERTY OF LC FUTURE CENTER, AND CONTAINS CONFIDENTIAL AND TRADE SECRET INFORMATION. THIS SHEET MAY NOT BE TRANSFERRED FROM THE CUSTODY OF THE COMPETENT DIVISION OF R&D DEPARTMENT EXCEPT AS AUTHORIZED BY LC FUTURE CENTER. NEITHER THIS SHEET NOR THE INFORMATION IT CONTAINS MAY BE USED BY OR DISCLOSED TO ANY THIRD PARTY WITHOUT PRIOR WRITTEN CONSENT OF LC FUTURE CENTER.</small>					
Size	Document Number	Date:	Wednesday, August 05, 2015	Sheet	68 of 83
C	BE460_NW-A551			Rev	1.0

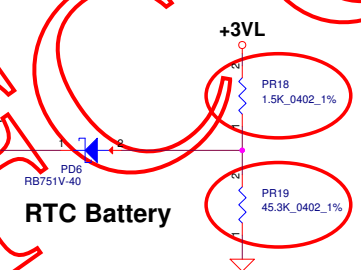
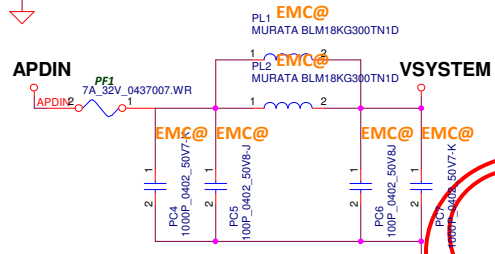
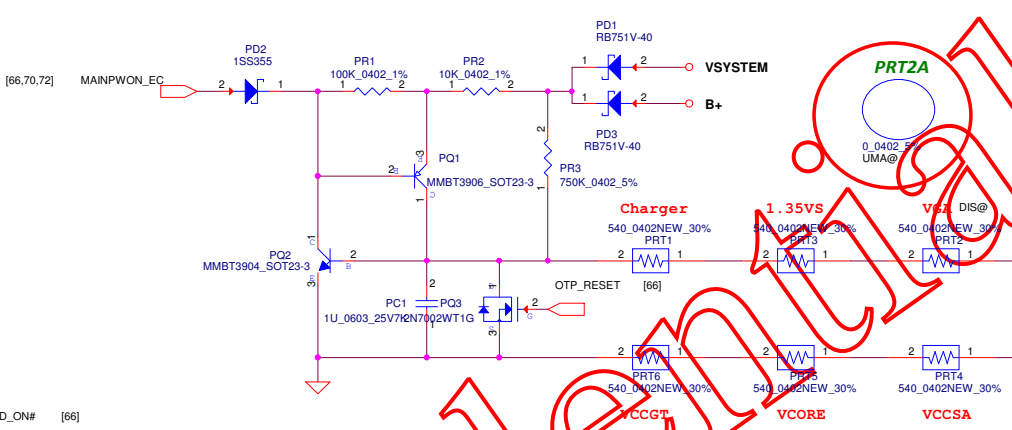
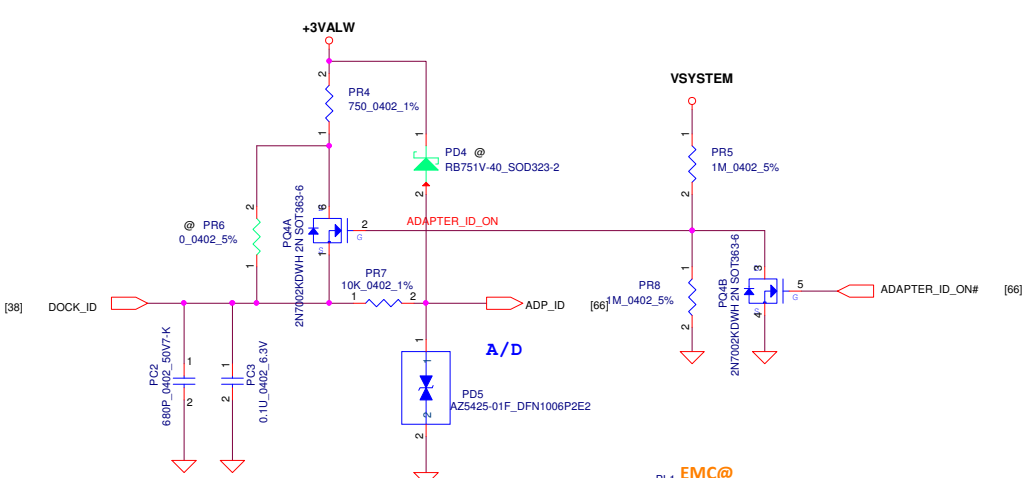

CONFIDENTIAL

Security Classification				LC Future Center Secret Data		Title	
Issued Date	2013/08/05	Deciphered Date	2014/12/31	DCIN / Vin Detector			
THIS SHEET OF ENGINEERING DRAWING IS THE PROPRIETARY PROPERTY OF LC FUTURE CENTER, AND CONTAINS CONFIDENTIAL AND TRADE SECRET INFORMATION. THIS SHEET MAY NOT BE TRANSFERRED FROM THE CUSTODY OF THE COMPETENT DIVISION OF R&D DEPARTMENT EXCEPT AS AUTHORIZED BY LC FUTURE CENTER NEITHER THIS SHEET NOR THE INFORMATION IT CONTAINS MAY BE USED BY OR DISCLOSED TO ANY THIRD PARTY WITHOUT PRIOR WRITTEN CONSENT OF LC FUTURE CENTER.							
Size	Document Number	AIVL2_NW-A351		Rev	1.0		
Date:	Wednesday, August 05, 2015			Sheet	69	of	83

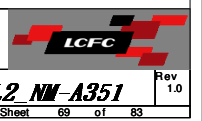

PRT7 under CPU bottom side :
 CPU thermal protection at 93 +/-3 degree C
 Recovery at 56 +/-3 degree C

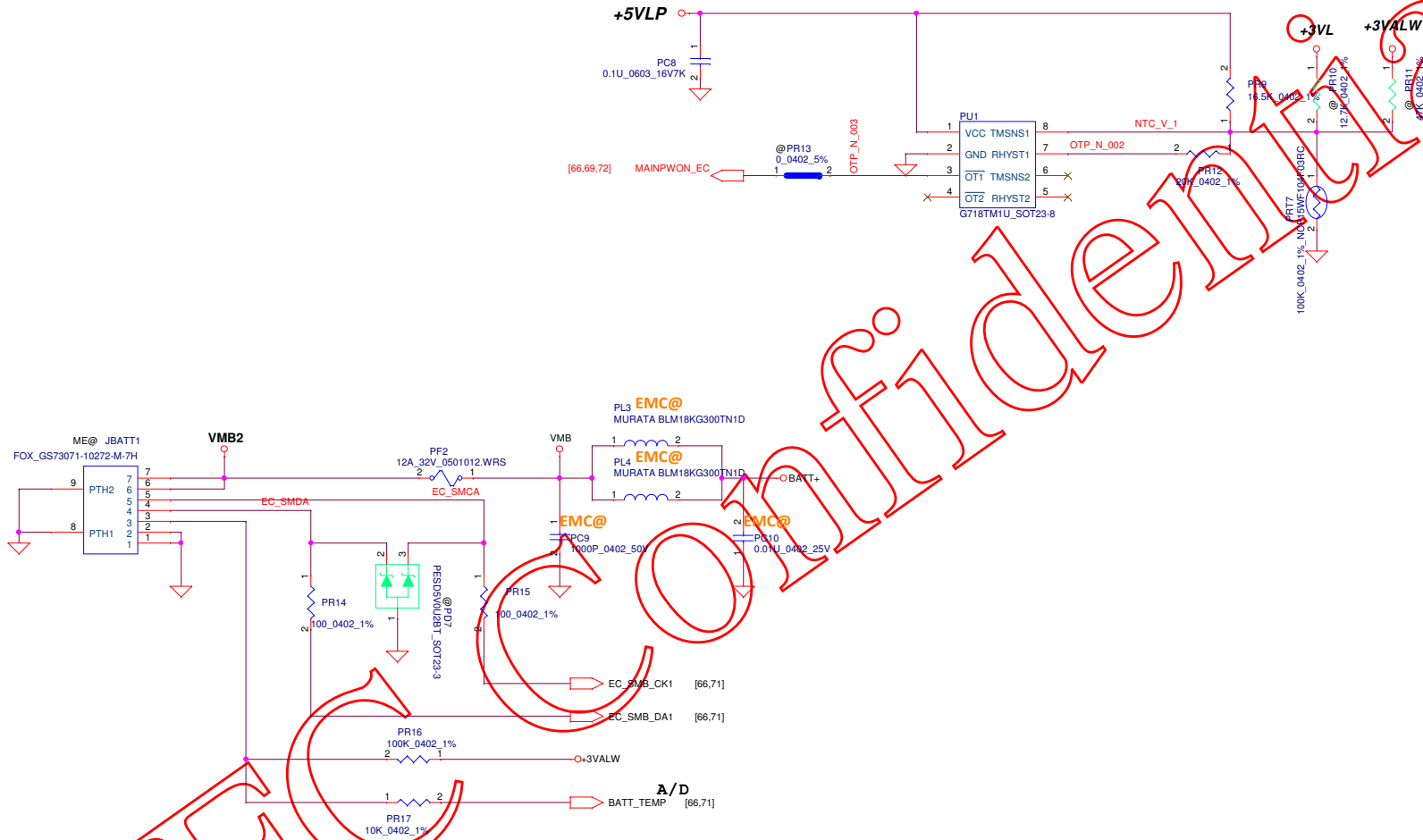

CONFIDENTIAL

Security Classification	LC Future Center Secret Data		
Issued Date	2013/08/05	Deciphered Date	2014/12/31
THIS SHEET OF ENGINEERING DRAWING IS THE PROPRIETARY PROPERTY OF LC FUTURE CENTER, AND CONTAINS CONFIDENTIAL AND TRADE SECRET INFORMATION. THIS SHEET MAY NOT BE TRANSFERRED FROM THE CUSTODY OF THE COMPETENT DIVISION OF R&D DEPARTMENT EXCEPT AS AUTHORIZED BY LC FUTURE CENTER NEITHER THIS SHEET NOR THE INFORMATION IT CONTAINS MAY BE USED BY OR DISCLOSED TO ANY THIRD PARTY WITHOUT PRIOR WRITTEN CONSENT OF LC FUTURE CENTER.			

Title		LCFC
BATTERY CONN/OTP		
Size	Document Number	Rev 1.0
Custom	A1VL2_NW-A351	
Date:	Wednesday, August 05, 2015	Sheet 70 of 83

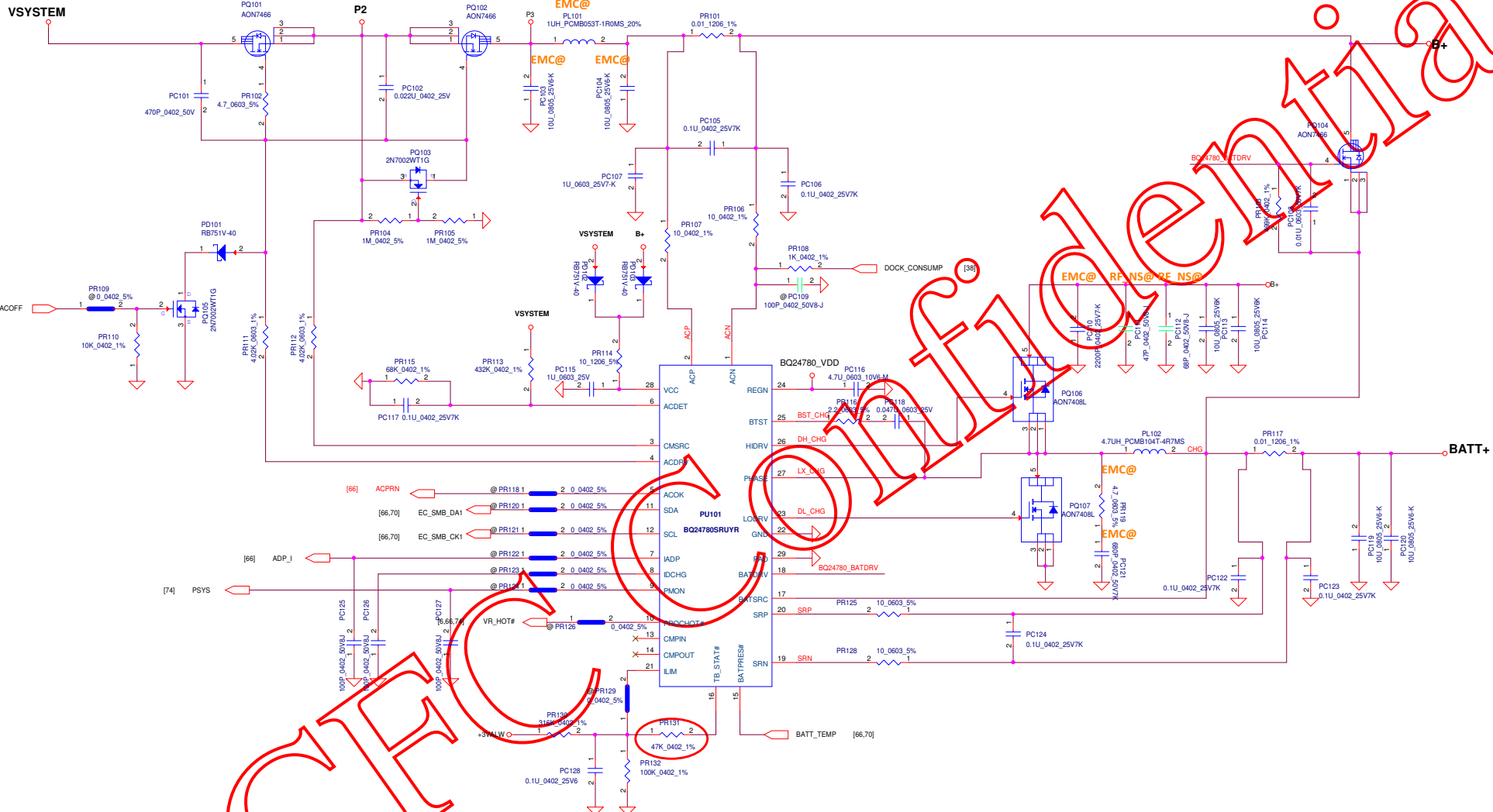

Security Classification	LC Future Center Secret Data	Title	 CHARGER
Issued Date	2013/08/05	Deciphered Date	
<small>THIS SHEET OF ENGINEERING DRAWING IS THE PROPRIETARY PROPERTY OF LC FUTURE CENTER, AND CONTAINS CONFIDENTIAL AND TRADE SECRET INFORMATION. THIS SHEET MAY NOT BE TRANSFERRED FROM THE CUSTODY OF THE COMPETENT DIVISION OF R&D DEPARTMENT EXCEPT AS AUTHORIZED BY LC FUTURE CENTER. NEITHER THIS SHEET NOR THE INFORMATION IT CONTAINS MAY BE USED BY OR DISCLOSED TO ANY THIRD PARTY WITHOUT PRIOR WRITTEN CONSENT OF LC FUTURE CENTER.</small>			
Size	Document Number	A1VL2-NW-A351	
Date:	Wednesday, August 05, 2015	Sheet	71 of 83

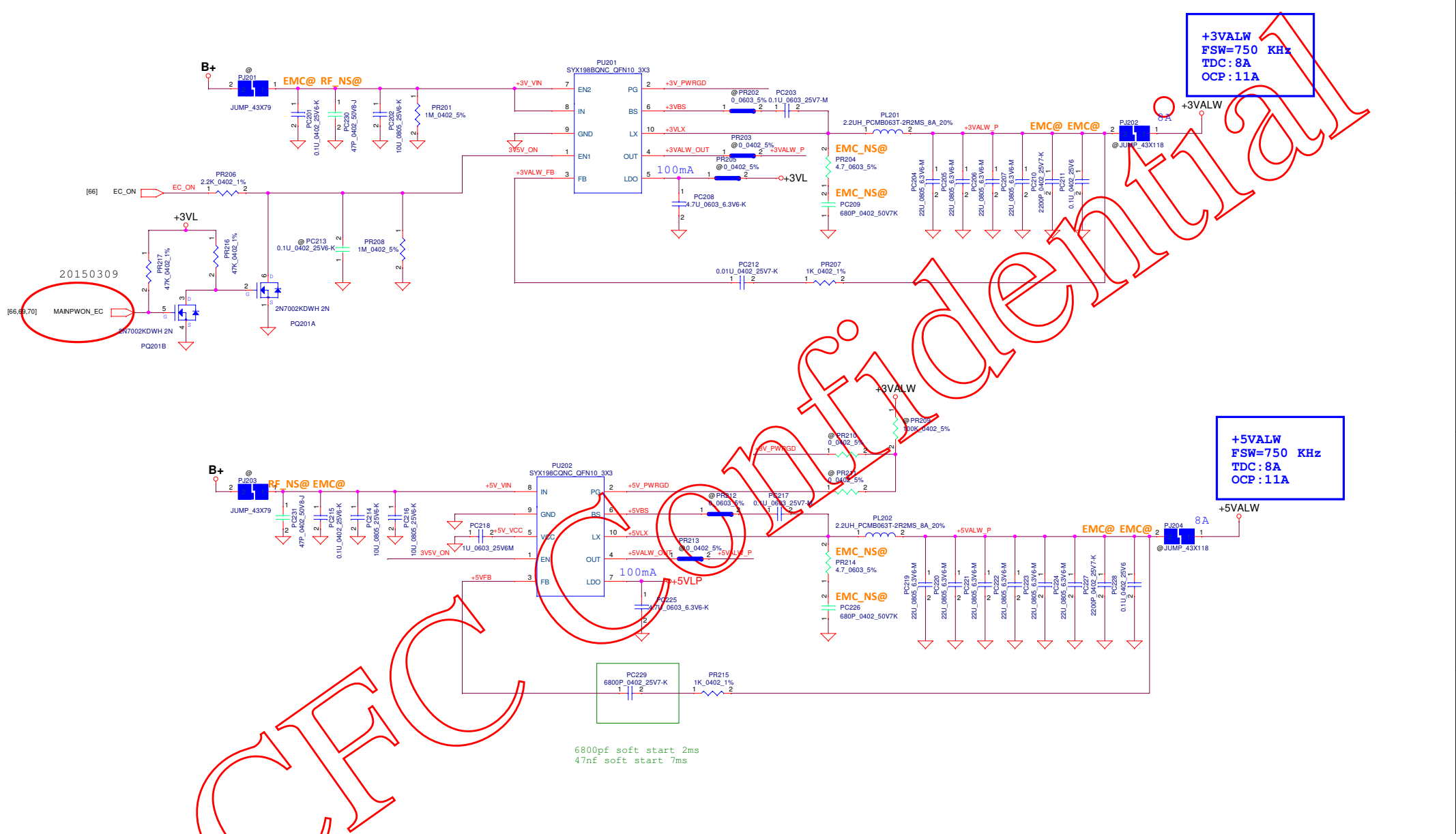

+3VALW
 FSW=750 KHz
 TDC: 8A
 OCP: 11A

+5VALW
 FSW=750 KHz
 TDC: 8A
 OCP: 11A

6800pF soft start 2ms
 47nF soft start 7ms

Security Classification	LC Future Center Secret Data		Title
Issued Date	2013/08/08	Deciphered Date	2013/08/05
THIS SHEET OF ENGINEERING DRAWINGS IS THE PROPRIETARY PROPERTY OF LC FUTURE CENTER, AND CONTAINS CONFIDENTIAL AND TRADE SECRET INFORMATION. THIS SHEET MAY NOT BE TRANSFERRED FROM THE CUSTODY OF THE COMPETENT DIVISION OF R&D DEPARTMENT EXCEPT AS AUTHORIZED BY LC FUTURE CENTER. NEITHER THIS SHEET NOR THE INFORMATION IT CONTAINS MAY BE USED BY OR DISCLOSED TO ANY THIRD PARTY WITHOUT PRIOR WRITTEN CONSENT OF LC FUTURE CENTER.			Size Custom Document Number AIVL2 NW-A351 Date: Wednesday, August 05, 2015 Sheet 72 of 83

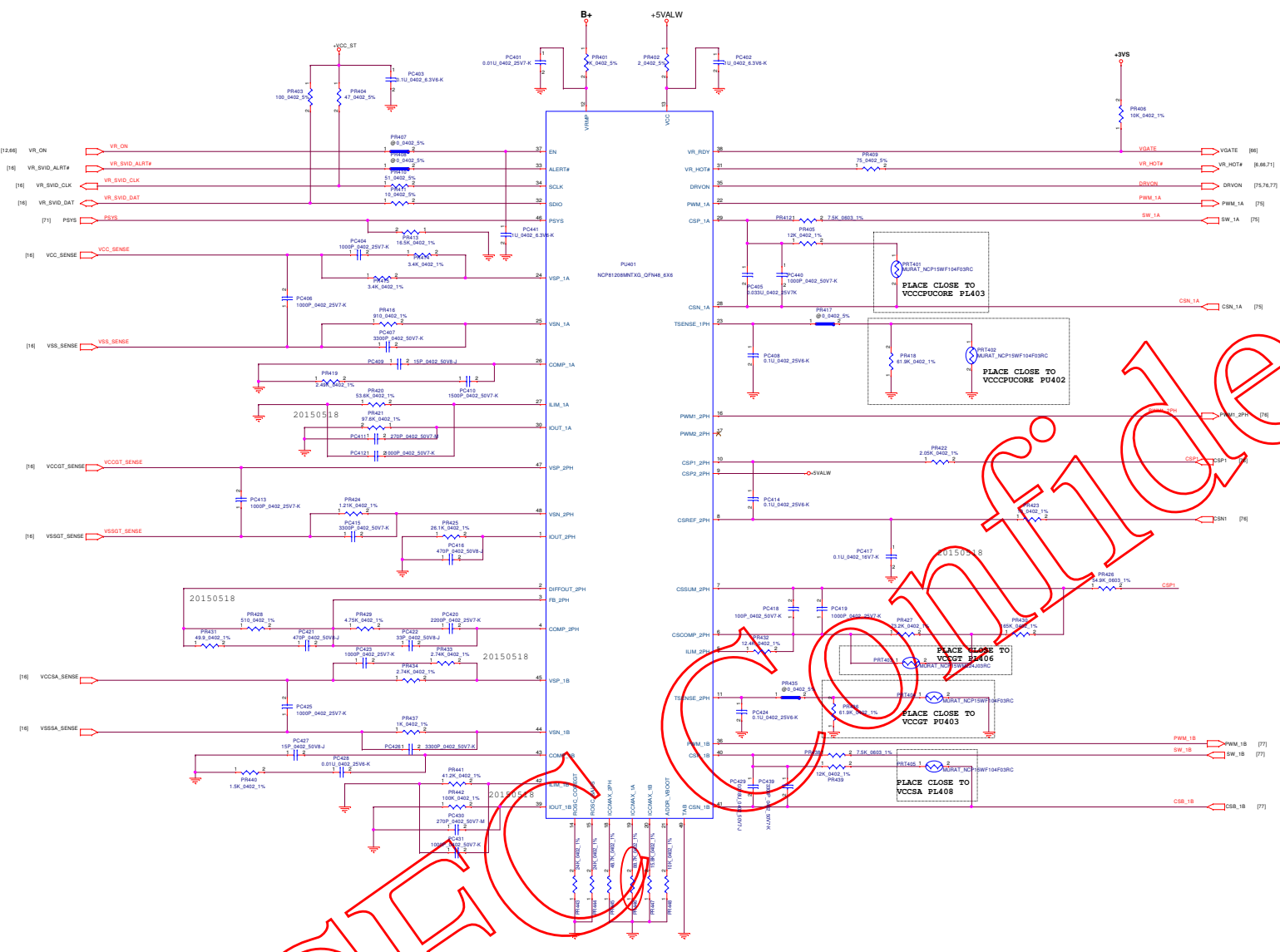

CONFIDENTIAL

Security Classification	LC Future Center Secret Data		Title
Issued Date	2013/08/05	Disciplined Date	2014/12/31
Doc No	IMVPS	Doc No	IMVPS
<small>THIS SHEET OF ENGINEERING DRAWING IS THE PROPRIETARY PROPERTY OF LC FUTURE CENTER AND CONTAINS CONFIDENTIAL AND UNCLASSIFIED INFORMATION. THIS SHEET MAY NOT BE REPRODUCED FROM THE CUSTODY OF THE CONTRACTOR WITHOUT THE WRITTEN PERMISSION OF LC FUTURE CENTER. ANY REPRODUCTION OF THIS SHEET WITHOUT THE WRITTEN PERMISSION OF LC FUTURE CENTER IS STRICTLY PROHIBITED. ANY REPRODUCTION OF THIS SHEET WITHOUT THE WRITTEN PERMISSION OF LC FUTURE CENTER IS STRICTLY PROHIBITED.</small>			
Scale	1:1	Doc No	IMVPS
Rev	1.1	Doc No	IMVPS

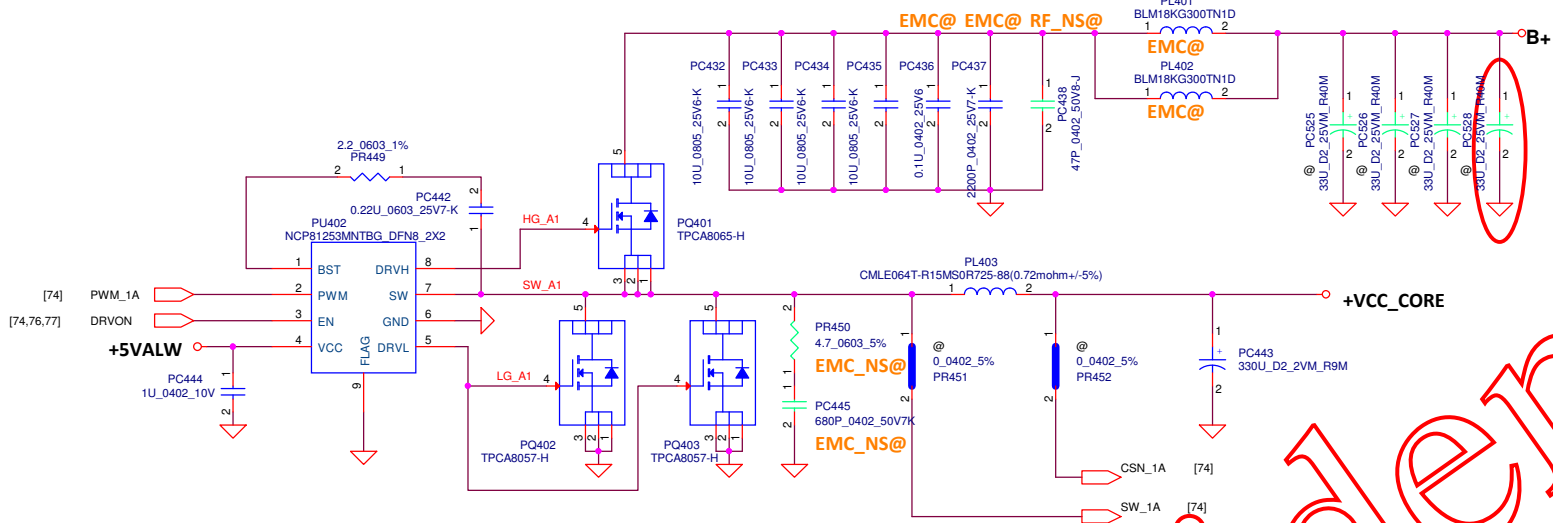

+VCC_CORE
TDC= 21A
IccMAX=28A
OCp = 30A

LCFC Confidential

Security Classification	LC Future Center Secret Data	
Issued Date	2013/08/05	Deciphered Date
		2014/12/31
<small>THIS SHEET OF ENGINEERING DRAWING IS THE PROPRIETARY PROPERTY OF LC FUTURE CENTER, AND CONTAINS CONFIDENTIAL AND TRADE SECRET INFORMATION. THIS SHEET MAY NOT BE TRANSFERRED FROM THE CUSTODY OF THE COMPETENT DIVISION OF R&D DEPARTMENT EXCEPT AS AUTHORIZED BY LC FUTURE CENTER. NEITHER THIS SHEET NOR THE INFORMATION IT CONTAINS MAY BE USED BY OR DISCLOSED TO ANY THIRD PARTY WITHOUT PRIOR WRITTEN CONSENT OF LC FUTURE CENTER.</small>		

Title		
+VCC_CORE		
Size	Document Number	AIVL2 NW-A351
Custom		
Date:	Wednesday, August 05, 2015	Sheet 75 of 83
		Rev 1.0

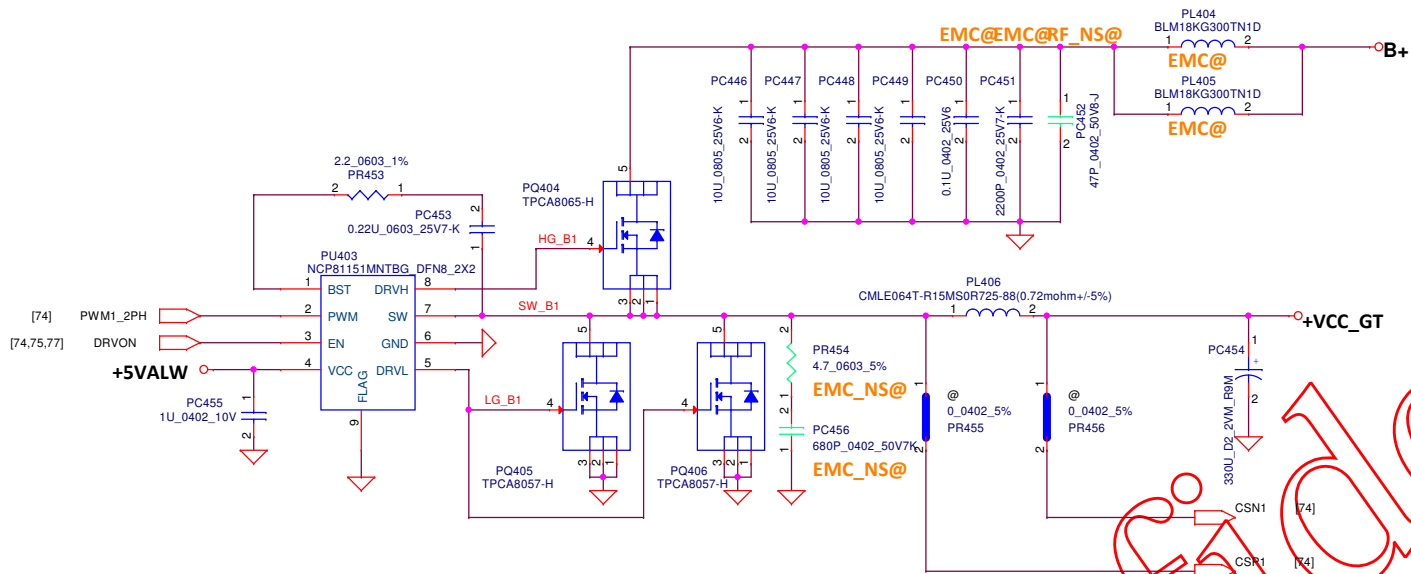

+VCC_GT
TDC= 18A
IccMAX=31A
OCP min = 40A

LCFEC

CONFIDENTIAL

Security Classification	LC Future Center Secret Data		
Issued Date	2013/08/05	Deciphered Date	2014/12/31

THIS SHEET OF ENGINEERING DRAWING IS THE PROPRIETARY PROPERTY OF LC FUTURE CENTER, AND CONTAINS CONFIDENTIAL AND TRADE SECRET INFORMATION. THIS SHEET MAY NOT BE TRANSFERRED FROM THE CUSTODY OF THE COMPETENT DIVISION OF R&D DEPARTMENT EXCEPT AS AUTHORIZED BY LC FUTURE CENTER NEITHER THIS SHEET NOR THE INFORMATION IT CONTAINS MAY BE USED BY OR DISCLOSED TO ANY THIRD PARTY WITHOUT PRIOR WRITTEN CONSENT OF LC FUTURE CENTER.

Title		
+VCC_GT		
Size Custom	Document Number	Rev 1.0
Date:	Wednesday, August 05, 2015	Sheet 76 of 83

A1VL2-NM-A351

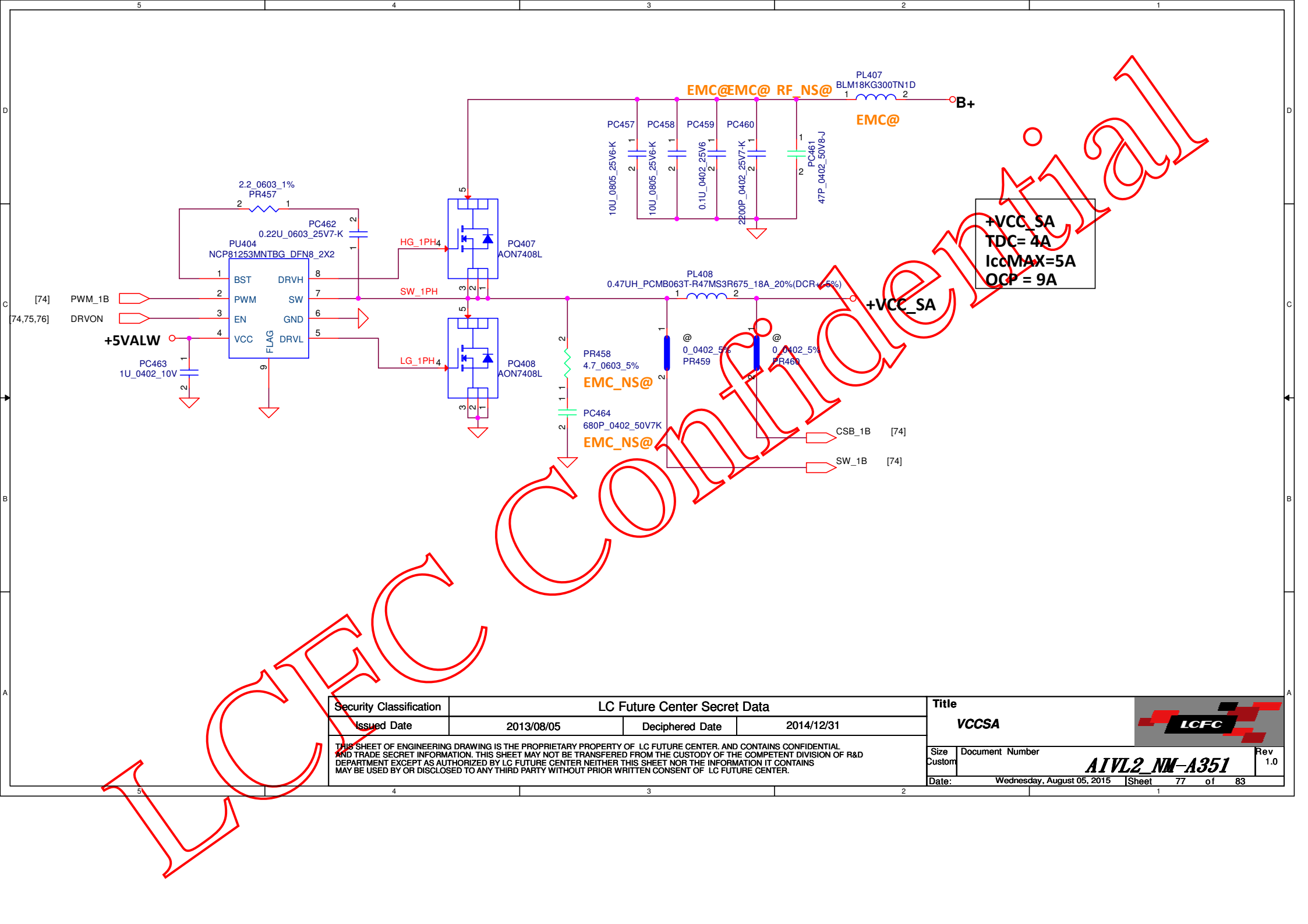

+VCC_SA
TDC= 4A
IccMAX=5A
OCp = 9A

Security Classification		LC Future Center Secret Data		Title	
Issued Date		2013/08/05	Deciphered Date	2014/12/31	VCCSA
<small>THIS SHEET OF ENGINEERING DRAWING IS THE PROPRIETARY PROPERTY OF LC FUTURE CENTER AND CONTAINS CONFIDENTIAL AND TRADE SECRET INFORMATION. THIS SHEET MAY NOT BE TRANSFERRED FROM THE CUSTODY OF THE COMPETENT DIVISION OF R&D DEPARTMENT EXCEPT AS AUTHORIZED BY LC FUTURE CENTER NEITHER THIS SHEET NOR THE INFORMATION IT CONTAINS MAY BE USED BY OR DISCLOSED TO ANY THIRD PARTY WITHOUT PRIOR WRITTEN CONSENT OF LC FUTURE CENTER.</small>					
Size	Document Number	Date:			Rev
Custom	AIVL2_NM-A351	Wednesday, August 05, 2015			1.0
		Sheet	77	of	83

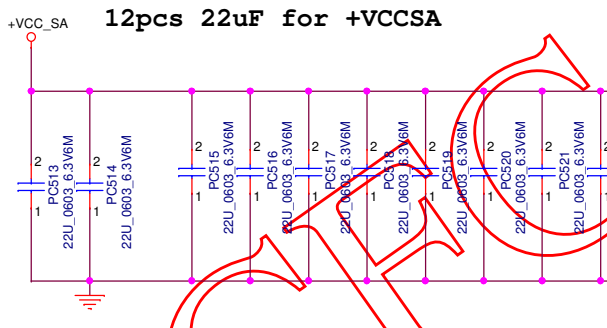
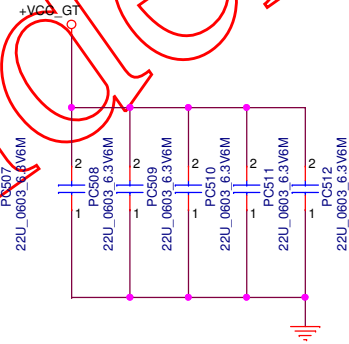
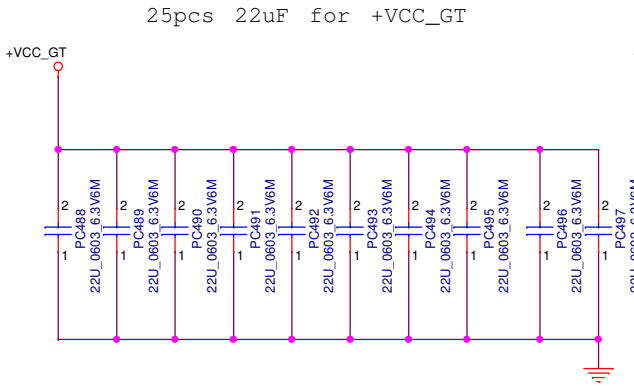
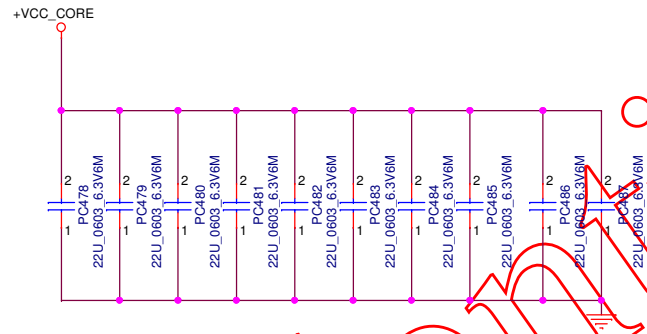
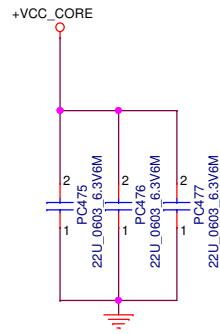
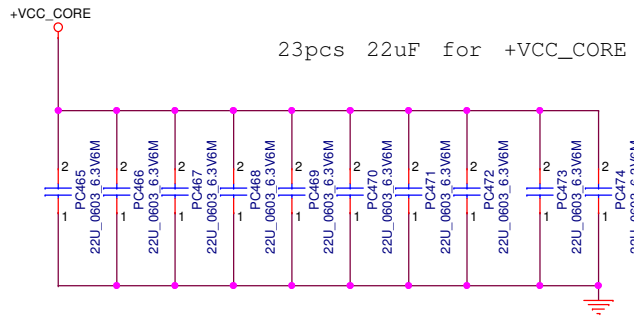

Security Classification	LC Future Center Secret Data		
Issued Date	2013/08/05	Deciphered Date	2014/12/31
THIS SHEET OF ENGINEERING DRAWING IS THE PROPRIETARY PROPERTY OF LC FUTURE CENTER, AND CONTAINS CONFIDENTIAL AND TRADE SECRET INFORMATION. THIS SHEET MAY NOT BE TRANSFERRED FROM THE CUSTODY OF THE COMPETENT DIVISION OF R&D DEPARTMENT EXCEPT AS AUTHORIZED BY LC FUTURE CENTER NEITHER THIS SHEET NOR THE INFORMATION IT CONTAINS MAY BE USED BY OR DISCLOSED TO ANY THIRD PARTY WITHOUT PRIOR WRITTEN CONSENT OF LC FUTURE CENTER.			

Title		
PROCESSOR DECOUPLING		
Size	Document Number	Rev
B	A1VL2 NM-A351	1.0
Date:	Wednesday, August 05, 2015	Sheet 78 of 83

ISL62771 Schematic for FT3 solution

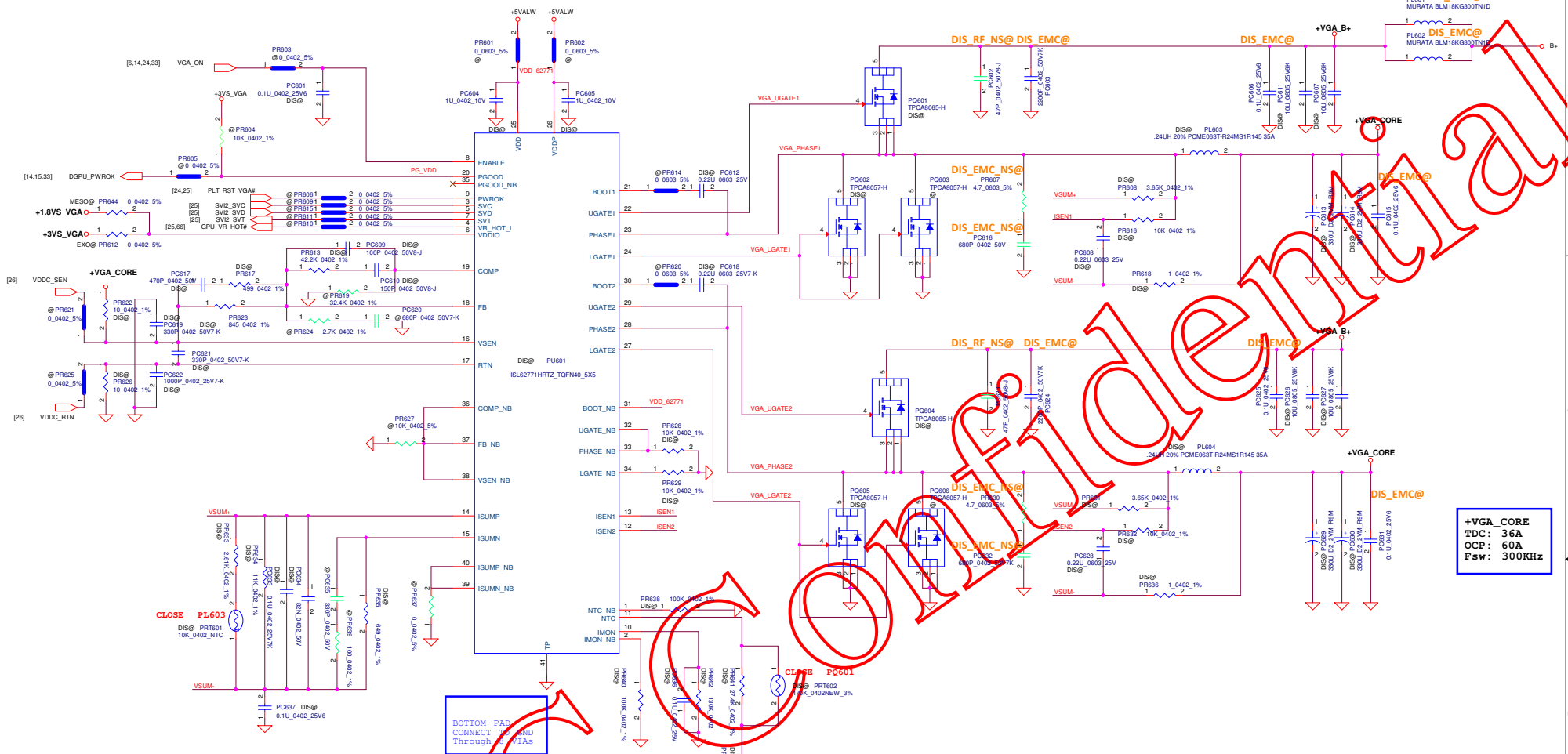

+VGA_CORE
 TDC: 36A
 OCP: 60A
 Fsw: 300KHz

BOTTOM PAD
 CONNECT THROUGH VIAS

Security Classification	LC Future Center Secret Data		Title	
Issued Date	2013/08/05	Deciphered Date	2014/12/31	
THIS SHEET OF ENGINEERING DRAWING IS THE PROPRIETARY PROPERTY OF LC FUTURE CENTER, AND CONTAINS CONFIDENTIAL AND TRADE SECRET INFORMATION. THIS SHEET MAY NOT BE TRANSMITTED FROM THE CUSTODY OF THE COMPETENT DIVISION OF R&D DEPARTMENT EXCEPT AS AUTHORIZED BY LC FUTURE CENTER. NEITHER THIS SHEET NOR THE INFORMATION IT CONTAINS MAY BE USED BY OR DISCLOSED TO ANY THIRD PARTY WITHOUT PRIOR WRITTEN CONSENT OF LC FUTURE CENTER.				Rev 1.0
Date: Wednesday, August 05, 2015 15:58:38				Rev 1.0

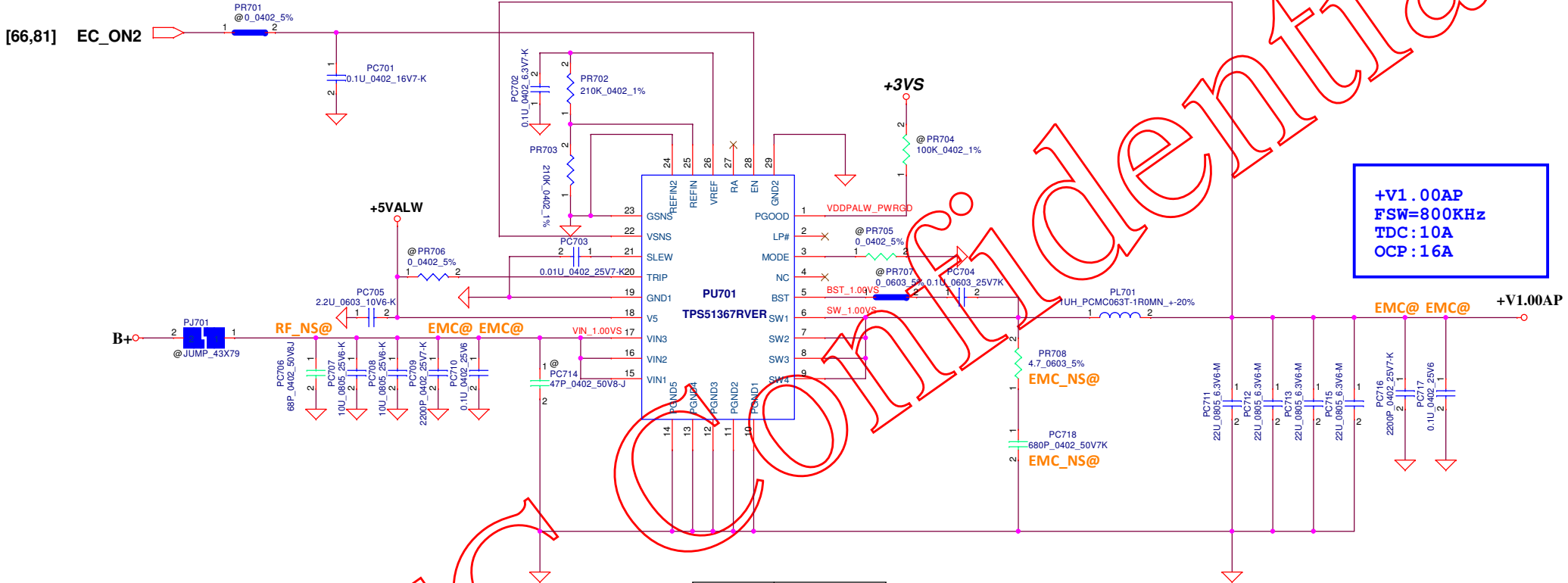

+V1.00AP
FSW=800KHz
TDC: 10A
OCP: 16A

Mode	Frequency
GND	400KHz
Float	800KHz

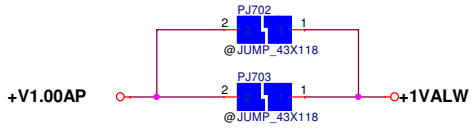

LCFC

LCFEC Confidential

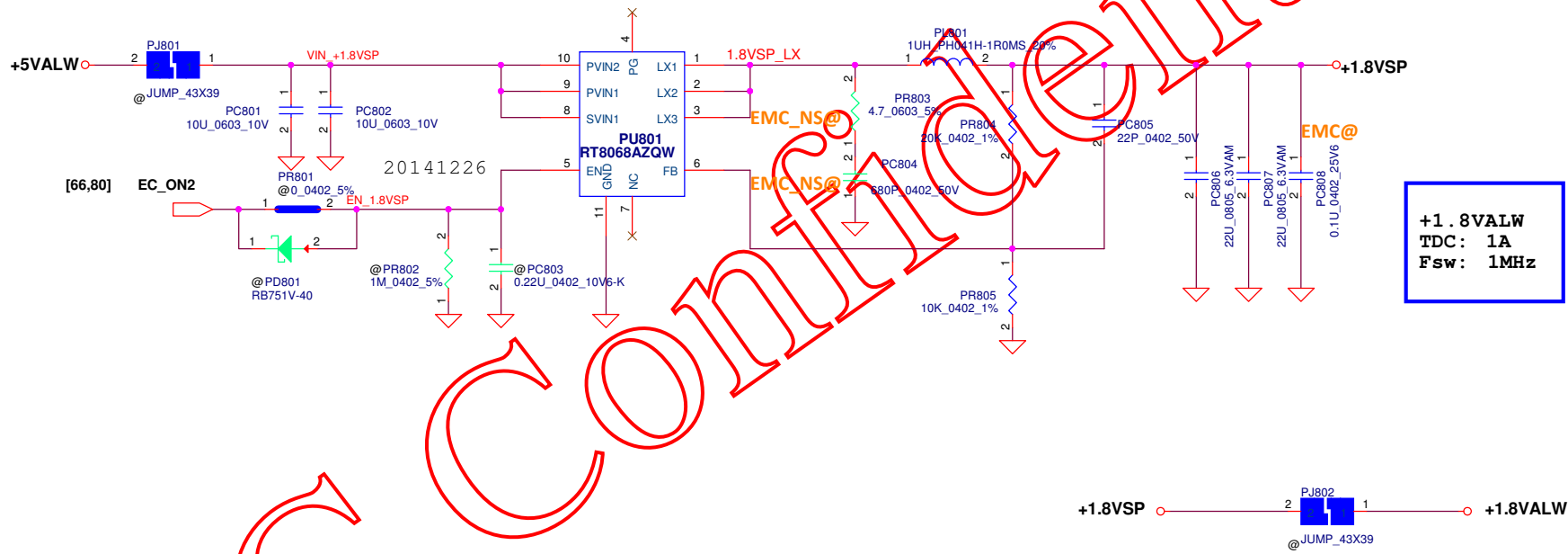

+1.8VALW
TDC: 1A
Fsw: 1MHz

Security Classification		LC Future Center Secret Data		Title	
Issued Date	2013/08/05	Deciphered Date	2014/12/31	+1.8VS_VGA	
THIS SHEET OF ENGINEERING DRAWING IS THE PROPRIETARY PROPERTY OF LC FUTURE CENTER, AND CONTAINS CONFIDENTIAL AND TRADE SECRET INFORMATION. THIS SHEET MAY NOT BE TRANSFERRED FROM THE CUSTODY OF THE COMPETENT DIVISION OF R&D DEPARTMENT EXCEPT AS AUTHORIZED BY LC FUTURE CENTER NEITHER THIS SHEET NOR THE INFORMATION IT CONTAINS MAY BE USED BY OR DISCLOSED TO ANY THIRD PARTY WITHOUT PRIOR WRITTEN CONSENT OF LC FUTURE CENTER.				Size	Document Number
				AIVE1 NM-A211	
				Date:	Wednesday, August 05, 2015
				Sheet	81 of 83
				Rev	1.0

HW PIR (Product Improve Record)

AIVE1 NM-XXXX SCHEMATIC CHANGE LIST
 REVISION CHANGE: 0.1
 GERBER-OUT DATE: 2013/10/15

NO DATE PAGE MODIFICATION LIST PURPOSE

LCFC Confidential

Security Classification	LC Future Center Secret Data			Title	XXXX	
Issued Date	2013/09/07	Deciphered Date	2014/09/07	Document Number		
<small>THIS SHEET OF ENGINEERING DRAWING IS THE PROPRIETARY PROPERTY OF LC FUTURE CENTER, AND CONTAINS CONFIDENTIAL AND TRADE SECRET INFORMATION. THIS SHEET MAY NOT BE TRANSFERRED FROM THE CUSTODY OF THE COMPETENT DIVISION OF R&D DEPARTMENT EXCEPT AS AUTHORIZED BY LC FUTURE CENTER. NEITHER THIS SHEET NOR THE INFORMATION IT CONTAINS MAY BE USED BY OR DISCLOSED TO ANY THIRD PARTY WITHOUT PRIOR WRITTEN CONSENT OF LC FUTURE CENTER.</small>					Size	Rev
					C	1.0
					Date:	Wednesday, August 05, 2015 Sheet 83 of 84

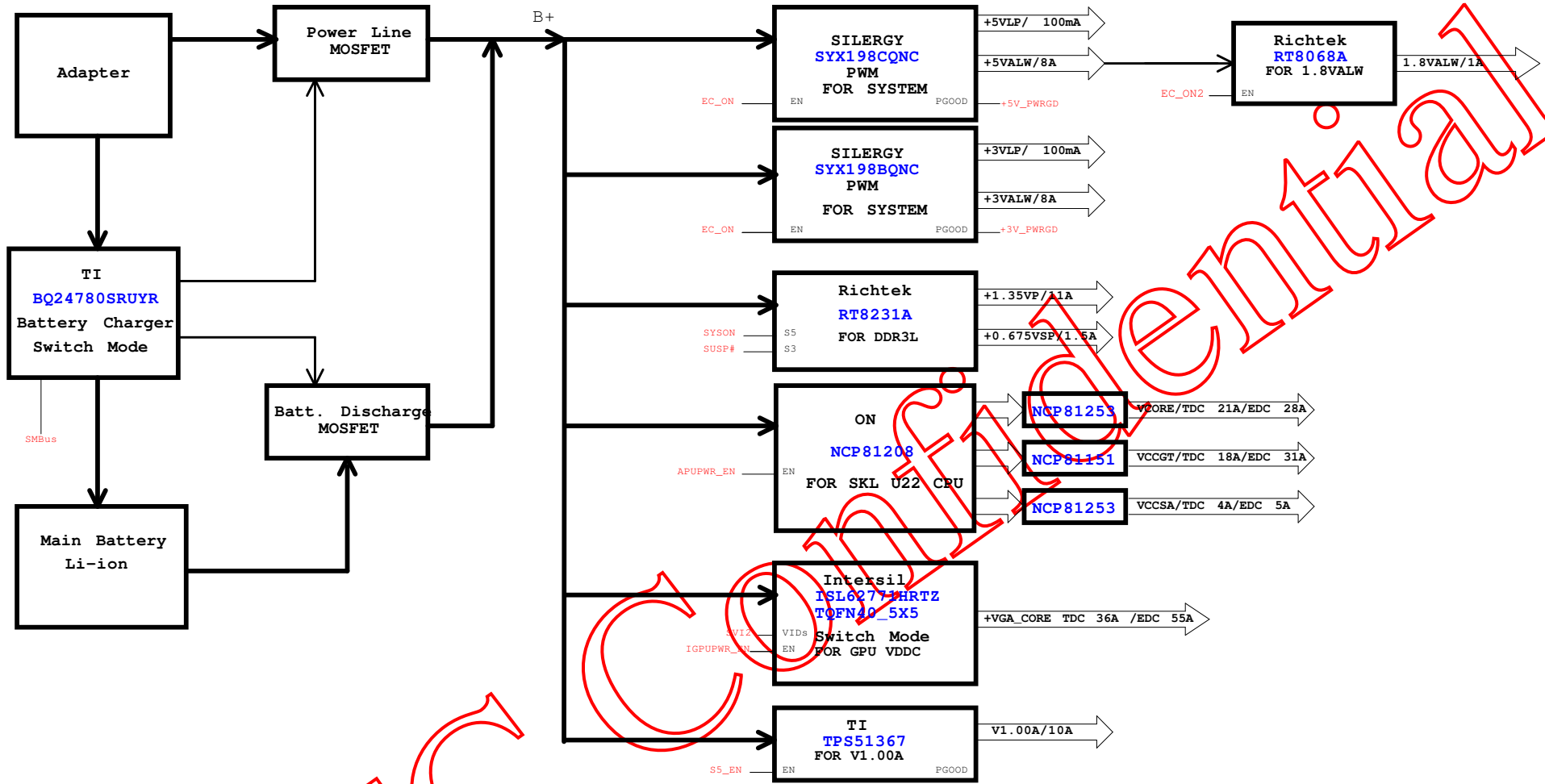

LCFC

Confidential

Security Classification	LC Future Center Secret Data		Title	
Issued Date	Deciphered Date	Block Diagram		
<small>THIS SHEET OF ENGINEERING DRAWING IS THE PROPRIETARY PROPERTY OF LC FUTURE CENTER, AND CONTAINS CONFIDENTIAL AND TRADE SECRET INFORMATION. THIS SHEET MAY NOT BE TRANSFERRED FROM THE CUSTODY OF THE COMPETENT DIVISION OF RAMP DEPARTMENT EXCEPT AS AUTHORIZED BY LC FUTURE CENTER. NEITHER THIS SHEET NOR THE INFORMATION IT CONTAINS MAY BE USED BY OR DISCLOSED TO ANY THIRD PARTY WITHOUT PRIOR WRITTEN CONSENT OF LC FUTURE CENTER.</small>				Size Document Number Custom AIVL2_NM-A351 Date: Wednesday, August 05, 2016 Sheet 84 of 84